

**Double clamping system
mechanically operated DS-M
hydraulically operated DS-H**

The compact and user-friendly double clamping system for two or optionally for four workpieces (DS 125).

Manual adjustment of the clamping range and the insertion tolerance using a spindle and locking screws. Manual clamping either with selectable clamping force using a torque wrench (mechanical) or a hand or foot-operated switch or programme-controlled with a separate pressure transducer (hydraulic). Suitable for single and series clamping. Safe loading and unloading using the 3rd hand function.

Highly economic for the production of small, medium and large batches in manual, semi-automatic or automatic operation.



**Double clamping system
DS 125/510 mechanical**

**Double clamping system
DS 100/420 mechanical**

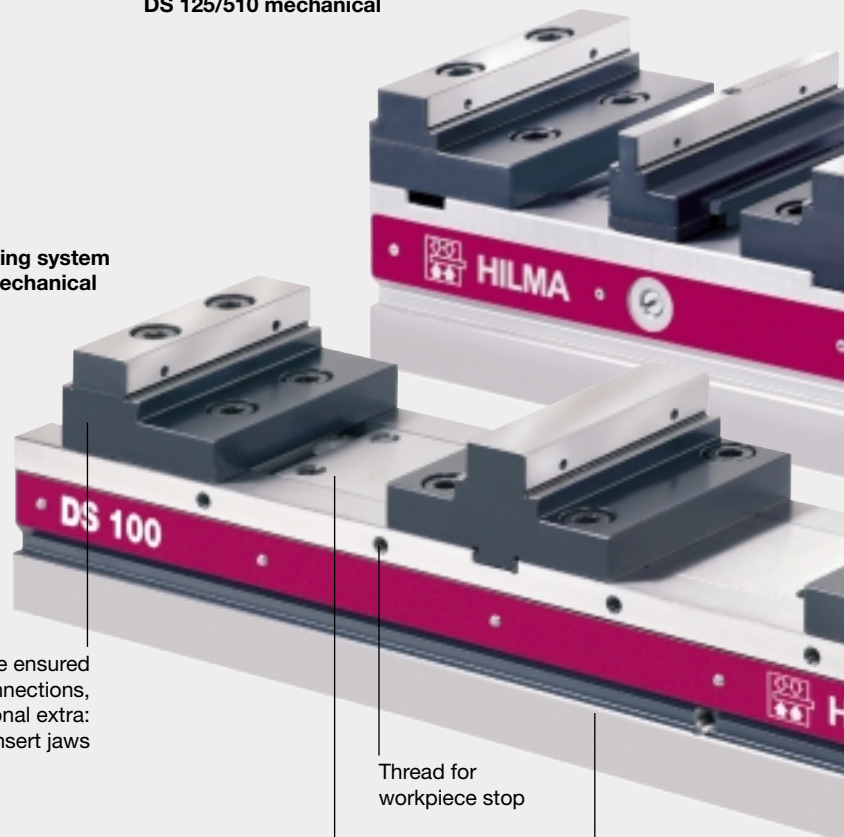

Simple jaw change ensured by screwed connections, optional extra: quick insert jaws

Thread for workpiece stop

Spindle area well protected, no uncovered apertures, optimum removal of chips and coolant

Clamping edge for clamping claws, optional fastening u internal grid holes (see pag

For individual production, small and medium batches: DS double clamping system, mechanically operated for efficient machining of workpieces having the same or different dimensions. Manual clamping / unclamping preferably using a torque wrench with selectable clamping force.

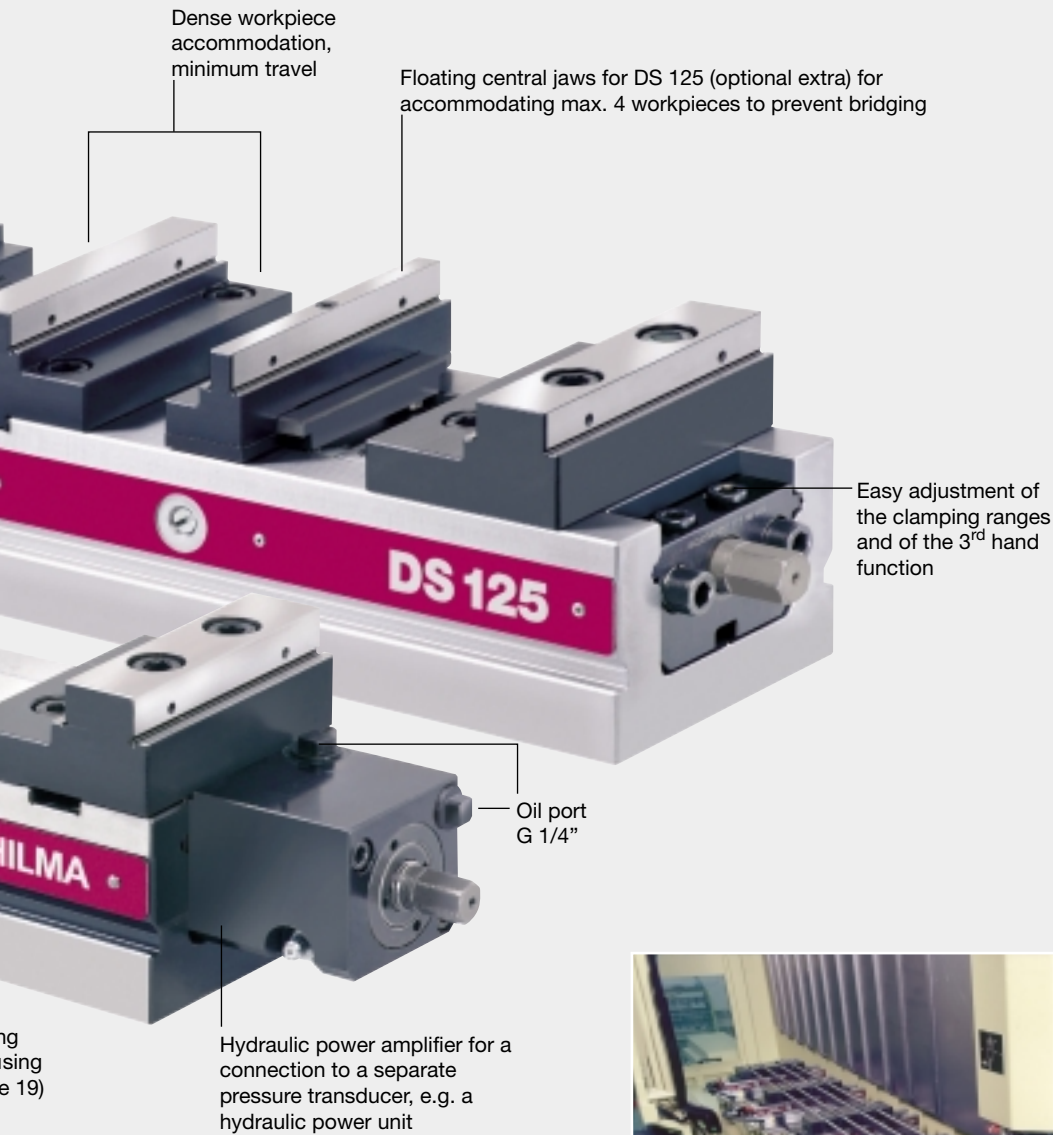

Maximum utilization of the working area:

The DS 125 clamping system can accommodate up to 4 workpieces having the same or different dimensions. This ensures maximum flexibility and economy!

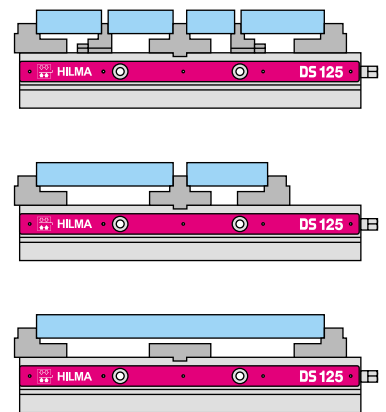

For medium and large-scale manufacture:
DS double-clamping system, hydraulically operated
for efficient machining of workpieces with short
cycle times.
Also suitable for arranging in rows for clamping
workpieces which require several clamping points.

Double clamping system DS 100 hydraulic and mechanical

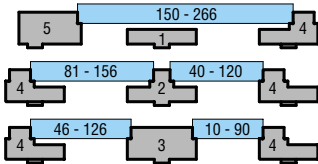

Item	Part no.	Designation
1	9.3791.5140	Guide plate
2	9.3791.5111	Central step jaw 26 mm
3	9.3791.5121	Central step jaw 86 mm
4	9.3791.5211	Central reversible jaw
5	9.3791.5341	Stop jaw, fixed

The standard clamping jaws enable 1 or 2 workpieces having the same or different dimensions to be accommodated. Maximum utilization of the clamping range between 227 and 343 mm using the fixed step jaw, part no. 9.3791.5311

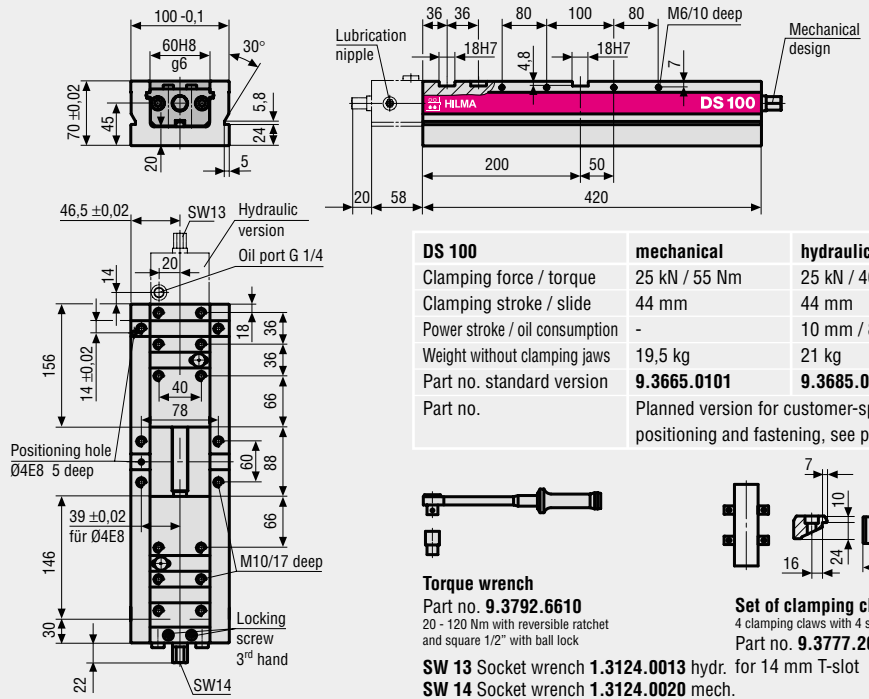

DS 100	mechanical	hydraulic
Clamping force / torque	25 kN / 55 Nm	25 kN / 400 bar
Clamping stroke / slide	44 mm	44 mm
Power stroke / oil consumption	-	10 mm / 8 cm ³
Weight without clamping jaws	19,5 kg	21 kg
Part no. standard version	9.3665.0101	9.3685.0101
Part no.	Planned version for customer-specific positioning and fastening, see page 19	

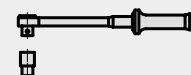

Torque wrench
Part no. 9.3792.6610
20 - 120 Nm with reversible ratchet and square 1/2" with ball lock

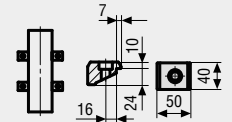

Set of clamping claws
4 clamping claws with 4 screws DIN 912
Part no. 9.3777.2011

SW 13 Socket wrench 1.3124.0013 hydr. for 14 mm T-slot
SW 14 Socket wrench 1.3124.0020 mech.

DS 100 standard jaws, case-hardened and ground with 8 mm steps (free space for tools and chips). Supplied including fastening screws.

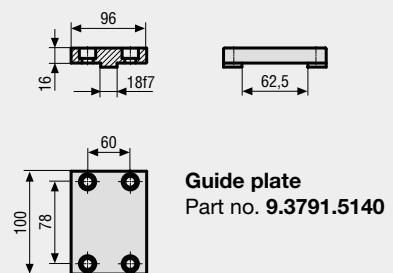
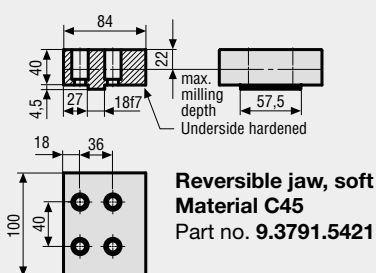
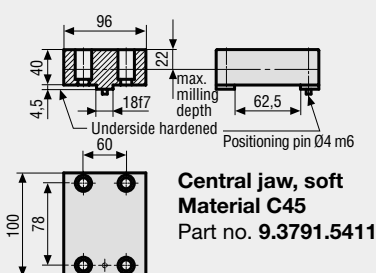
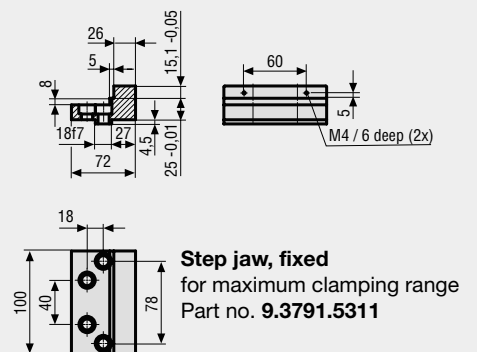
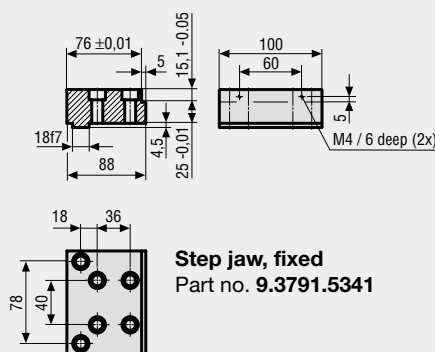
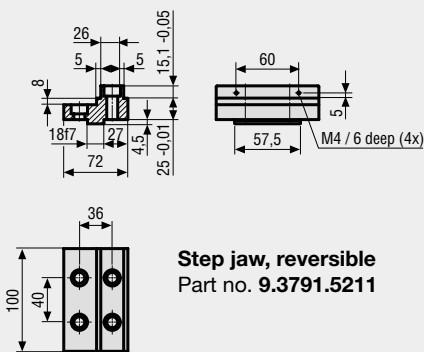
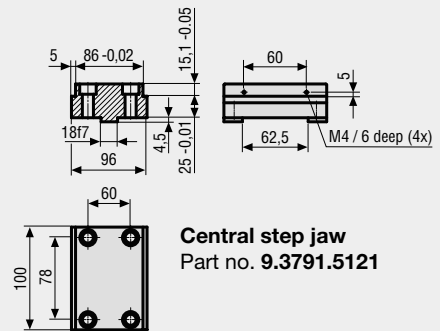
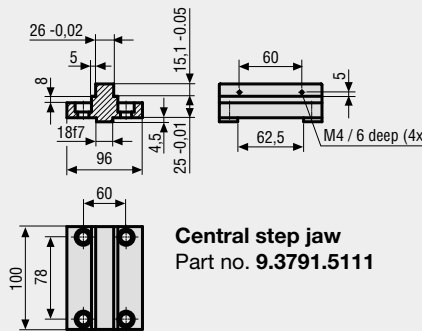

KM 10 mounting holes for all jaws

Double clamping system DS 125 Overall length 430 mm hydraulic and mechanical

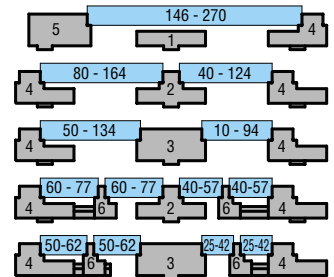

Item	Part no.	Designation
1	9.3791.6140	Guide plate
2	9.3791.6111	Central step jaw 22 mm
3	9.3791.6121	Central step jaw 82 mm
4	9.3791.6211	Central reversible jaw
5	9.3791.6341	Step jaw, fixed
6	9.3791.6541	Central jaw, floating

The standard clamping jaws enable 1 or 4 workpieces having the same or different dimensions to be accommodated. Maximum utilization of the clamping range between 226 and 430 mm using the fixed reversible step jaw, part no. 9.3791.6311

Double clamping system DS 125 Overall length 510 mm hydraulic and mechanical

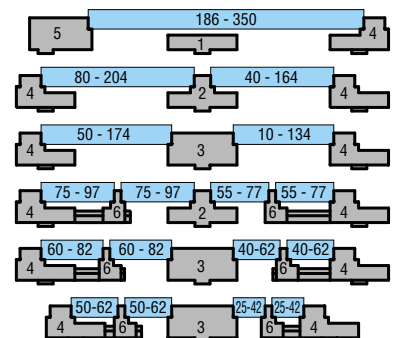

Item	Part no.	Designation
1	9.3791.6140	Guide plate
2	9.3791.6111	Central step jaw 22 mm
3	9.3791.6121	Central step jaw 82 mm
4	9.3791.6211	Central reversible jaw
5	9.3791.6341	Step jaw, fixed
6	9.3791.6511	Central jaw, floating

The standard clamping jaws enable 1 or 4 workpieces having the same or different dimensions to be accommodated. Maximum utilization of the clamping range between 226 and 430 mm using the fixed reversible step jaw, part no. 9.3791.6311

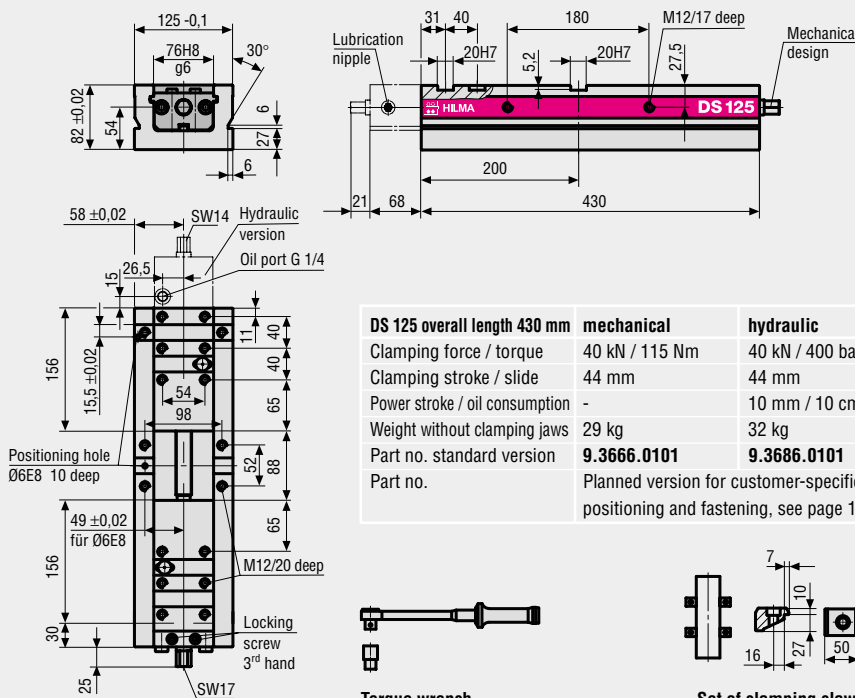

DS 125 overall length 430 mm	mechanical	hydraulic
Clamping force / torque	40 kN / 115 Nm	40 kN / 400 bar
Clamping stroke / slide	44 mm	44 mm
Power stroke / oil consumption	-	10 mm / 10 cm ³
Weight without clamping jaws	29 kg	32 kg
Part no. standard version	9.3666.0101	9.3686.0101
Part no.	Planned version for customer-specific positioning and fastening, see page 19	

Torque wrench

Part no. **9.3792.6610**
20 - 120 Nm with reversible ratchet and square 1/2" with ball lock

SW 14 Socket wrench **1.3124.0020** hydr.
SW 17 Socket wrench **1.3124.0017** mech.

Set of clamping claws

4 clamping claws with 4 screws DIN 912

Part no. **9.3777.3011**

M12 x 45 for T-Slot 14 mm

Part no. **9.3777.3021**

M16 x 50 for T-Slot 18 mm

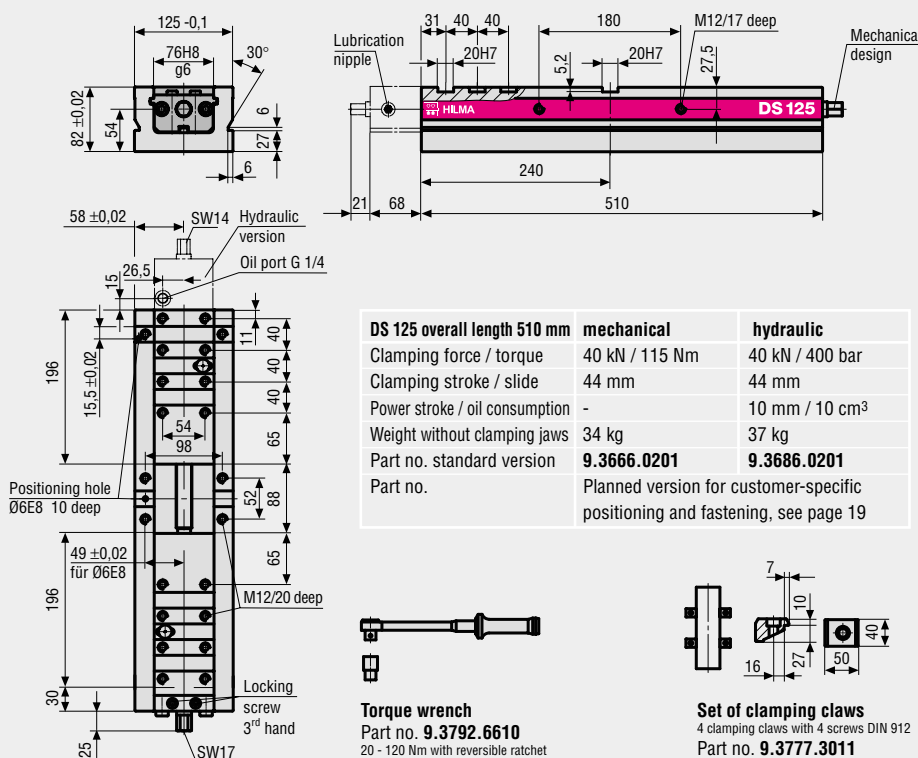

DS 125 overall length 510 mm	mechanical	hydraulic
Clamping force / torque	40 kN / 115 Nm	40 kN / 400 bar
Clamping stroke / slide	44 mm	44 mm
Power stroke / oil consumption	-	10 mm / 10 cm ³
Weight without clamping jaws	34 kg	37 kg
Part no. standard version	9.3666.0201	9.3686.0201
Part no.	Planned version for customer-specific positioning and fastening, see page 19	

Torque wrench

Part no. **9.3792.6610**
20 - 120 Nm with reversible ratchet and square 1/2" with ball lock

SW 14 Socket wrench **1.3124.0020** hydr.
SW 17 Socket wrench **1.3124.0017** mech.

Set of clamping claws

4 clamping claws with 4 screws DIN 912

Part no. **9.3777.3011**

M12 x 45 for T-Slot 14 mm

Part no. **9.3777.3021**

M16 x 50 for T-Slot 18 mm

Clamping jaws see page 18

**DS 125 standard jaws, case-hardened and ground with 8 mm steps (free space for tools and chips).
Supplied including fastening screws.**

<p>Guide plate Part no. 9.3791.6140</p>	<p>Central step jaw Part no. 9.3791.6111</p>	<p>Central step jaw 82 mm Part no. 9.3791.6121</p>
<p>Step jaw, reversible Part no. 9.3791.6211</p>	<p>Step jaw, fixed Part no. 9.3791.6341</p>	<p>Step jaw, fixed for maximum clamping range Part no. 9.3791.6311</p>
<p>Central jaw floating x = 50 and 56 mm Part no. 9.3791.6541 for overall length 430 x = 50 and 80 mm Part no. 9.3791.6511 for overall length 510</p>	<p>Standard jaws, soft, for milling workpiece contours, steps, stops etc. Supplied including fastening screws.</p> <p>Central jaw, soft Material C45 Part no. 9.3791.6411</p>	<p>Reversible jaw, soft Material C45 Part no. 9.3791.6421</p>

**Slim-Flex jaw system, case-hardened and ground with 8 mm steps (free space for tools and chips).
Supplied including fastening screws. The continuously adjustable jaw inserts ensure optimum tool access without the risk of collision.
Smallest clamping dimension: 26 mm**

<p>Central jaw without step jaw inserts Part no. 9.3791.6170</p> <p>Central jaw with step jaw inserts Part no. 9.3791.6171</p>	<p>Movable jaw without step jaw inserts Part no. 9.3791.6270</p> <p>Movable jaw with step jaw inserts Part no. 9.3791.6271</p>	<p>Jaw insert made from steel C 45, soft for Slim-Flex jaw system for preparation of steps with specific dimensions by the customer Part no. 5.5050.0119</p>
--	--	---

KM 10 mounting holes for all jaws



This page may be used as a pattern for copying

Planned version of DS double clamping system DS

Customers' requests concerning design, positioning and fastening are met using planned versions. Please determine parameters and advise us accordingly together with your enquiry or order.

Enquiry

Order

Quantity = _____

Parameter jaw width / length of base / operation

DS 100 base length 420 mm

DS 125 base length 430 mm

DS 125 base length 510 mm

9.3665.7101 mechanical

9.3666.7101 mechanical

9.3666.7201 mechanical

9.3685.7101 hydraulic

9.3686.7101 hydraulic

9.3686.7201 hydraulic

Parameter hole pattern keyway across length

without keyway across length



left-hand central right-hand



for keyblock
DIN 6322

keyway across length 20 H7, 6,5 mm deep

central = _____

offset to the left = _____ mm ± 0,02

offset to the right = _____ mm ± 0,02

Parameter positioning holes

without positioning holes

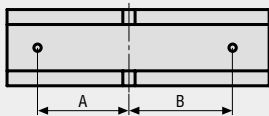

12 H7

A = _____ mm ± 0,02

16 H7

B = _____ mm ± 0,02

Parameter mounting grid

without mounting grid

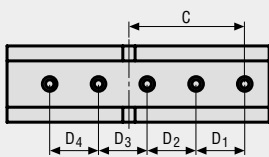

KM 12 (DS 100/125)

C = _____ mm

KM 16 (DS 125)

D₁ = _____ mm

D₂ = _____ mm

D₃ = _____ mm

D₄ = _____ mm

Parameter hole pattern for vertical design

without drill pattern for vertical design

Grid for vertical configuration, back-to-back.

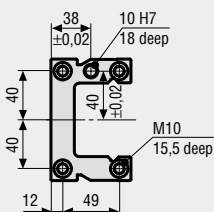

Hole pattern DS 100

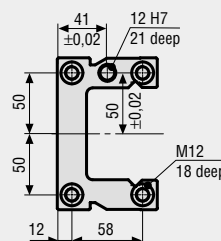

Drill pattern DS 125

Date

Stamp

Signature