

The **Profile Damper Type TS** from the innovative ACE TUBUS series is a maintenance free, self-contained damping element made from a special Co-Polyester Elastomer. As a result of the almost linear damping characteristic it provides a very smooth energy absorption with minimum reaction loads on the machine. The excellent temperature characteristic of the material provides consistent damping performance over a temperature range of -40°C to 90°C. The low installed weight, the economic price and the long operating life of up to 1 million cycles makes this an attractive alternative to hydraulic end position damping, if the moving mass does not have to stop in an exact datum position and it is not necessary to absorb 100% of the incoming energy.

The **space-saving** package size ranges from \varnothing 14 mm up to 107 mm and is very simply and quickly installed with the supplied specially stepped mounting screw.

The TS series have been specially developed to provide **Maximum Energy Capacity** in the **Minimum Mounting Space** in the capacity range from 2 Nm up to 910 Nm.

Life expectancy is extremely high; **up to twenty times** longer than for urethane dampers, **up to ten times** longer than rubber buffers and **up to five times** longer than steel springs.



Overload capacity: For emergency use only (1 cycle) it is possible to exceed the W_3 rating by +40%.

Environment: Resistant to oil, grease, seawater and to microbe or chemical attack. Excellent UV and ozone resistance. Material does not absorb water or swell.

Dynamic force range: 670 N to 24 000 N

Temperature range: -40°C to 90°C

Energy absorption: 26% to 56%

Material hardness rating: Shore 40D

Mounting: in any position

Impact velocity range:
up to max. 5 m/s

Mounting screw torque:

M4: 4 Nm

M5: 6 Nm

M6: 10 Nm

M12: 85 Nm

M16: 210 Nm

On request: special strokes, -characteristics, -spring rates, -sizes and materials.

Calculation and selection to be approved by ACE.



Ordering Example TS 44-23

TUBUS axial soft _____
 Outer- ϕ 44 mm _____
 Stroke 23 mm _____

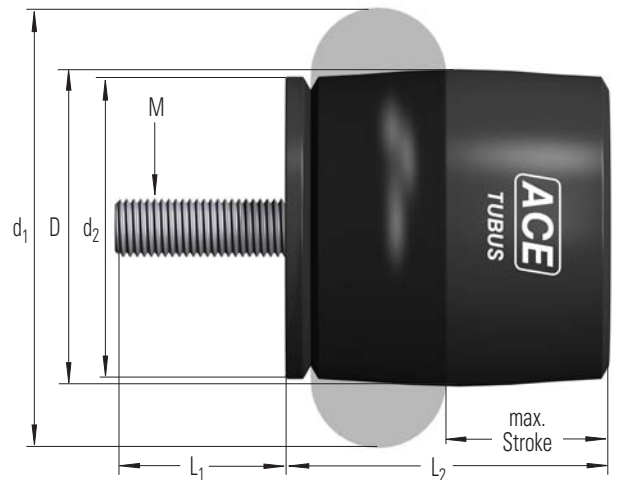

The calculation and selection of the required profile damper should be carried out or be approved by ACE.

Dimensions and Capacity Chart

Type	*W ₃ Nm/cycle	max Stroke mm	D	L ₁	M	L ₂	d ₁	d ₂	Weight in gm
TS 14-7	2	7	14	4	M4	15	19	13	3
TS 18-9	4	9	18	5	M5	18	24	16	4
TS 20-10	6	10	20	6	M6	21	27	19	5
TS 26-15	15	15	26	6	M6	28	37	25	10
TS 32-16	25	16	32	6	M6	32	44	30	15
TS 35-19	30	19	35	6	M6	36	48	33	25
TS 40-19	35	19	40	6	M6	38	51	34	30
TS 41-21	45	21	41	12	M12	41	55	38	40
TS 44-23	65	23	44	12	M12	45	60	40	45
TS 48-25	80	25	48	12	M12	49	64	44	60
TS 51-27	90	27	51	12	M12	52	69	47	70
TS 54-29	115	29	54	12	M12	55	73	50	80
TS 58-30	135	30	58	12	M12	59	78	53	100
TS 61-32	160	32	61	16	M16	62	83	56	120
TS 64-34	195	34	64	16	M16	66	87	60	145
TS 68-36	230	36	68	16	M16	69	92	63	165
TS 75-39	285	39	75	16	M16	75	101	69	210
TS 78-40	340	40	78	16	M16	79	105	72	245
TS 82-44	395	44	82	16	M16	84	110	75	275
TS 84-43	460	43	84	16	M16	85	115	78	300
TS 90-47	565	47	90	16	M16	92	124	84	395
TS 107-56	910	56	107	16	M16	110	147	100	615

* Max. Energy capacity per cycle for continuous use. For emergency use only (1 cycle) it is possible to exceed this rating by +40%.

Characteristics of Type TS 44-23

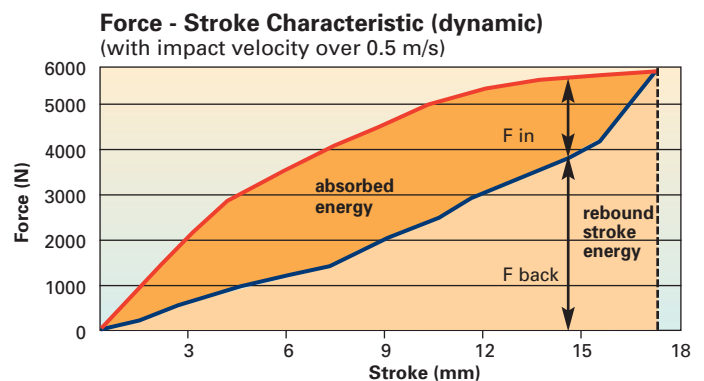
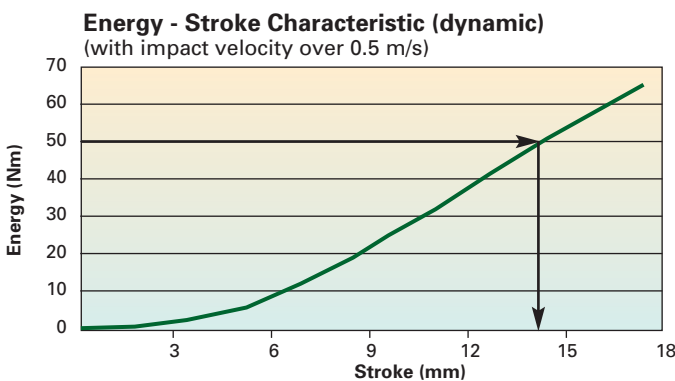

With the aid of the characteristic curves above you can estimate the proportion of the total energy that will be absorbed. Example: With impact energy of 50 Nm the Energy-Stroke diagram shows that a stroke of about 14 mm is needed. On the Force-stroke diagram you can estimate the proportion of absorbed energy to rebound energy at this stroke length.

Dynamic ($v > 0.5$ m/s) and static ($v \leq 0.5$ m/s) characteristics of all types are available on request.