

The innovative **LOCKED-Series P** offers pneumatic rod clamping in both directions of movement for rod diameters of 16 mm up to 50 mm. The values of hydraulic clamping are met and exceeded at **holding forces of up to 27 000 N**.

LOCKED-P is the optimum method of safety clamping since pneumatics failure means immediate clamping of the system. Only marginal system costs arise, in comparison to hydraulic systems.

ACE LOCKED-P clamping elements win over due to their compact design, thus enabling short additional rod lengths.

Because of the **modular design**, several segments can be added on top of one another, and it is thus possible to design the required clamping force for each individual application.

Dimensions of base/cover plates and flange diameters match those of **ISO-Pneumatic Cylinders**.

Within the LOCKED-Series P, ACE also offers a model with **additional safety for highest possible safety standards** in relation to vertical axes. After clamping of the piston rod, the clamping can only be released again when the axis is driven vertically upwards.

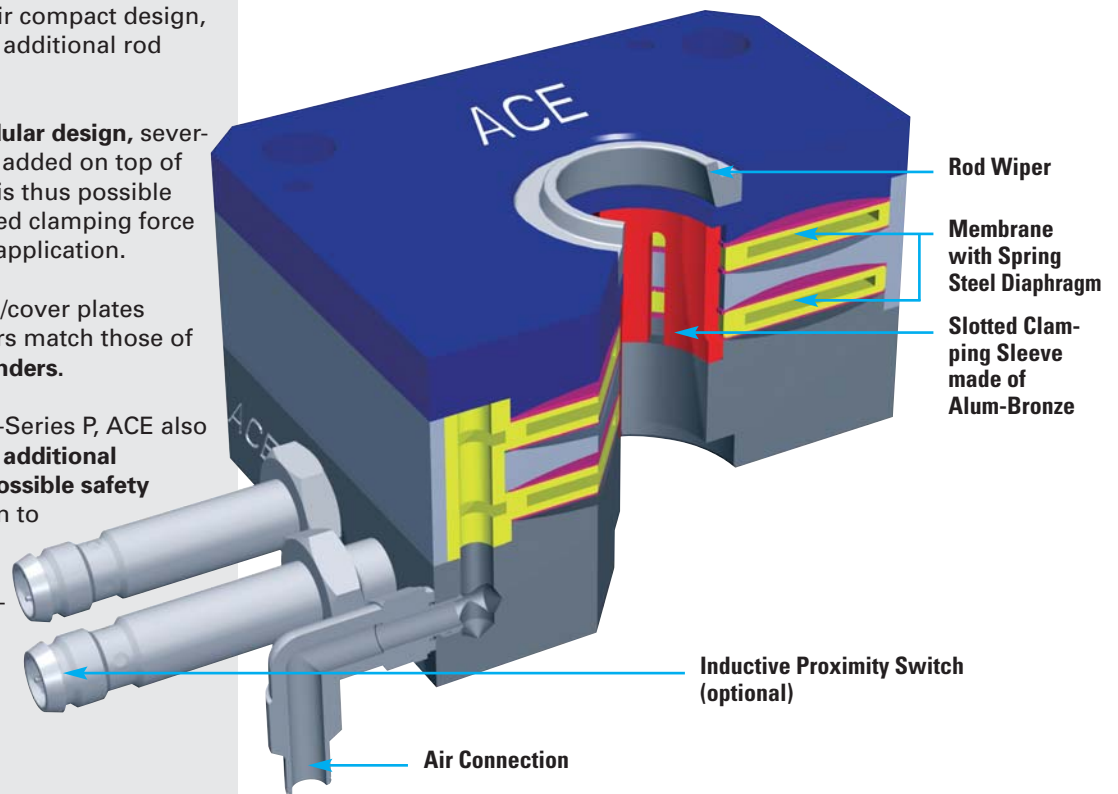

Rod diameter: 16 to 50 mm (hardened piston rod recommended)

Holding forces: up to 27 000 N

Clamping cycles: 100 000 (for higher values please consult ACE)

Material: Clamping body and milled parts: tool steel; spring steel plates: spring steel.

Operating pressure: 4 bar (automotive) or 6 bar

Pressure medium: Dried filtered air.

Operating temperature range: 10 to 45°C

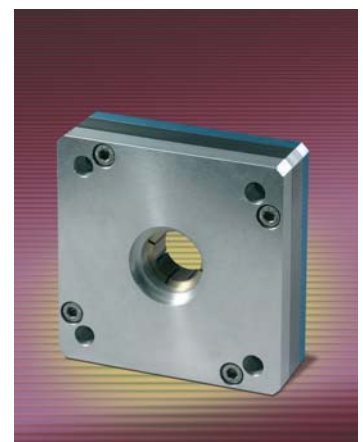

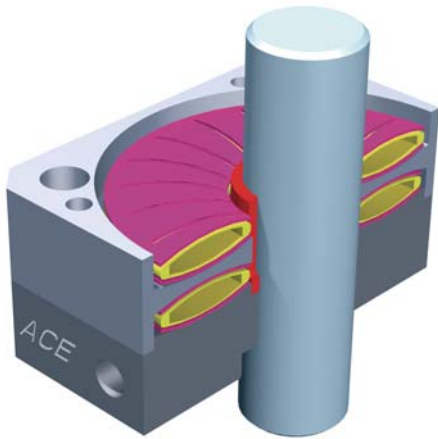

LOCKED-P Released

The chambers between the spring steel diaphragms are filled with compressed air. The diaphragms are elastically deformed and at the same time shortened in the radial direction. Since the spring steel diaphragms are slotted in the inner diameter, the diameter enlarges, the clamping sleeve springs radially outwards, and the rod is released.

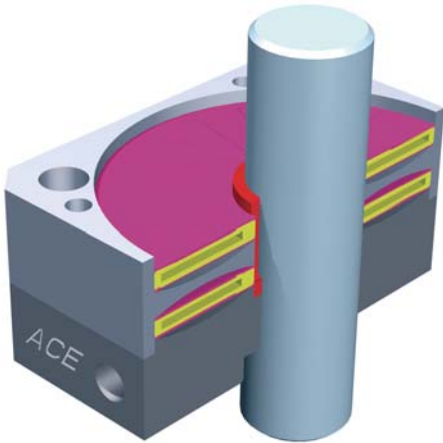

LOCKED-P Activated

The air pressure in the chamber between the spring steel diaphragms is released. The diaphragms spring back into their normal position. They press the slotted clamping sleeve against the rod, thereby clamping it against it. This ensures optimum **safety clamping**.

Models Locked-P

Standard model ACE LOCKED-P

The ACE LOCKED-P standard model is the basis for the entire range. The basic function, as described above, is found in all models. The body dimensions and the bore sizes are designed to suit the individual pneumatic cylinder types. This model range is highly flexible due to the tiered bore diameters for corresponding rod diameters. In addition this flexibility is increased by its intelligent modular design. The clamping force can be easily increased by applying several clamping units together. By arranging "X" number of clamping units between the base and cover plates, "X" times the clamping force can be obtained.

For the standard model, the corresponding nominal size for the following rod diameters are possible:

- Nominal size 63 mm:** 12 mm, 14 mm, 16 mm, 18 mm and 20 mm
- Nominal size 80 mm:** 16 mm, 18 mm, 20 mm, 22 mm, 24 mm and 25 mm
- Nominal size 125 mm:** 28 mm, 30 mm, 32 mm, 35 mm, 36 mm and 40 mm

ACE LOCKED-P model for ISO pneumatic cylinders

The base and cover plates for this model are matched to the flange dimensions of the corresponding ISO cylinders. Due to the difference with ISO cylinders, this model is constructed larger than the above described model. The corresponding dimensions can be taken from the data sheet on the next page. The middle clamping unit is identical to the standard model.

Note: The nominal stroke of the applicable ISO pneumatic cylinder is reduced according to the construction length of the clamping unit. End-of-travel damping is not applicable.

Do not use LOCKED-P clamping elements as positive stop!

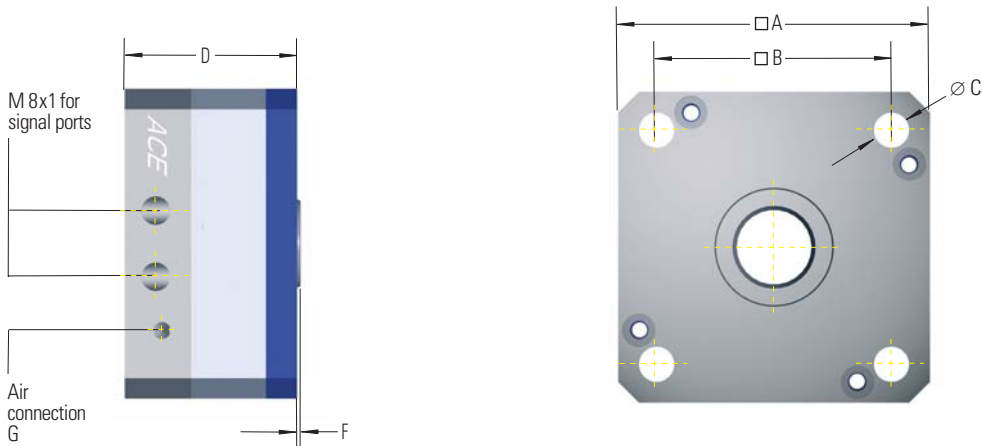

Version for ISO-Cylinders

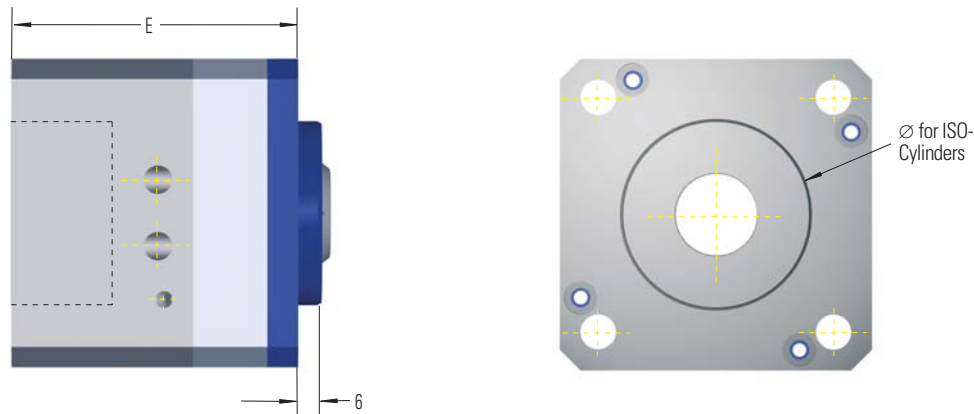

18

Ordering Example

Rod clamping unit _____
 Cylinder nominal size 80 mm _____
 Rod diameter 25 mm _____
 Number of clamping units 1 _____
 Series number is assigned by ACE _____

PC 80-25-1-X

Complete Details Required when Ordering:

- Desired opening pressure
- Standard model or ISO-Cylinder
- Number of clamping modules
- Required holding force
- Operating mode (dry, oiled, greased)

The calculation and selection of the correct clamping device should be made or approved by ACE. Use the request form on the next page.

Dimensions and Capacity Chart

Type Part number	A	B	C	D	E	F	G	Holding Force*		Weight	
								Opening Pressure 4 bar N	Opening Pressure 6 bar N	Standard kg	ISO
PC 63-20-1	75	56.5	8.5	41.5	67.5	2.1	M5	1 400	2 000	0.80	1.10
PC 63-20-2	75	56.5	8.5	59.5	85.5	2.1	M5	2 520	3 600	1.20	1.50
PC 63-20-3	75	56.5	8.5	77.5	103.5	2.1	M5	3 780	5 400	1.70	2.00
PC 80-25-1	96	72	10.5	49.5	73.5	2.14	G1/8	2 100	3 000	1.30	1.80
PC 80-25-2	96	72	10.5	63.5	87.5	2.14	G1/8	3 780	5 400	2.10	2.60
PC 80-25-3	96	72	10.5	83.5	107.5	2.14	G1/8	5 670	8 100	2.90	3.40
PC 125-40-1	145	110	13	51.6	95.6	3	G1/8	7 000	10 000	3.60	5.70
PC 125-40-2	145	110	13	75.2	119.2	3	G1/8	12 600	18 000	5.60	7.70
PC 125-40-3	145	110	13	98.8	142.8	3	G1/8	18 900	27 000	7.70	9.80

* The listed holding forces are reached under optimum conditions. We recommend a safety factor of > 10 %. Please note that surface, material and cleanliness of the rod as well as wear and tear and the use rod wipers lead to different holding forces. Test the clamping needed for series production or safety applications in its used application environment and measure the actual values.