



STARK

Zero point mounting *system 1000*

SPEEDY module plate, size 10 kN







Invest successfully and increase efficiency





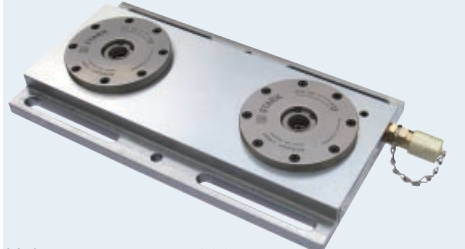

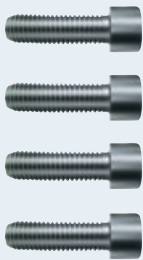
Enhance the productivity of your company

■ SPEEDY module plates – for efficient setting-up

Module plate start set, with overpressure release, order no. 803710

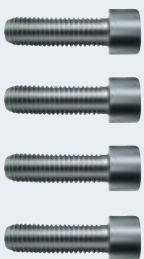
 <p>Hole gauge: 200 mm Insertion force: 2x 10'000 N Operating pressure: 80 bar Dimensions: 340 x 188 x 45 mm</p>				
<p>Consisting of:</p>	<p>804 209 Retractable nipple with zero point</p>	<p>931 059 Cyl. head screw M12x40</p>	<p>704 020 Washer</p>	<p>803 411 Footpump, system pressure 80 bar air pressure max. 6 bar</p>

Module plate extension set, order no. 803 711

 <p>Hole gauge: 200 mm Insertion force: 2x 10'000 N Operating pressure: 80 bar Dimensions: 340 x 188 x 45 mm</p>				
<p>Consisting of:</p>	<p>931 059 Cyl. head screw M12x40</p>	<p>704 020 Washer</p>	<p>804 392 Swivel screw connector 804 369 Swivel screw connector</p>	<p>P00036 MS-Pipe Ø 4/6x80</p>

Module plate accessories

					
<p>804 209 Retractable nipple with zero point</p>	<p>804 230 Retractable nipple with balancer</p>	<p>804 238 Retractable nipple without centering</p>	<p>804 259 Positioning pin</p>	<p>704 161 Slidingblock with pin</p>	<p>804 255 Torque wrench 804 257 Socket</p>
					
<p>804 254 Retractable nipple key</p>	<p>804 368 Coupling</p>	<p>803 790 Rupture plug</p>	<p>803 791 Nut for T-slot M12x14</p>		

The SPEEDY module plate keeps you flexible -always

■ SPEEDY module plate – Potential multiplier for your production

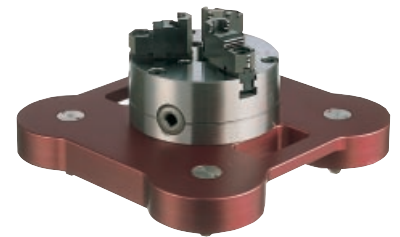
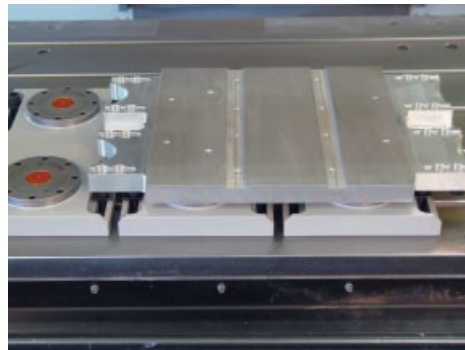
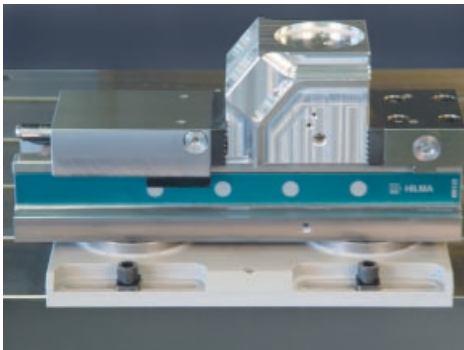
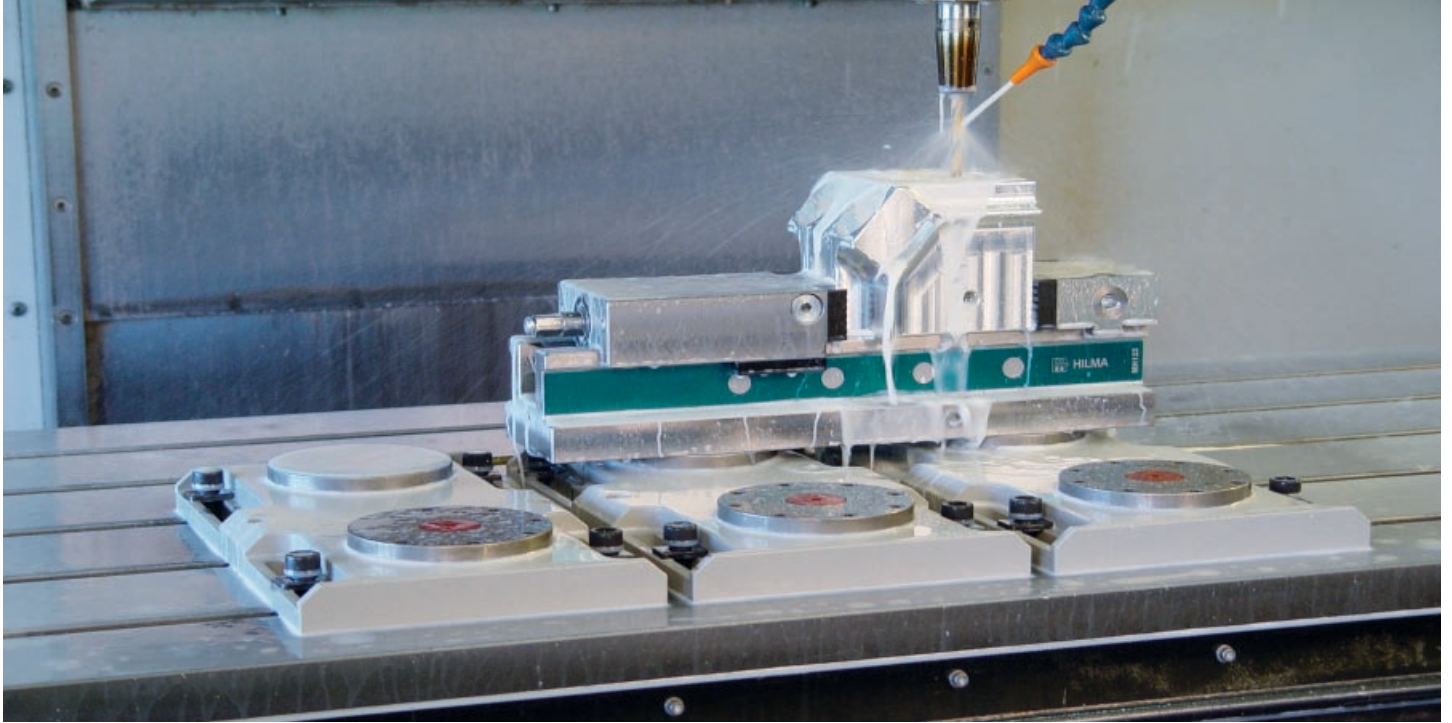

Jaw chuck palette (see main catalogue)

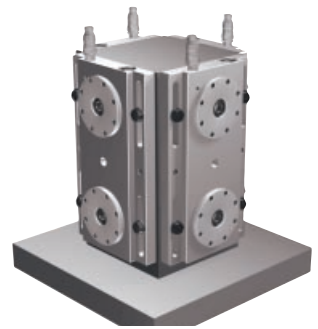

Module plate on mounting tower (versions on request)

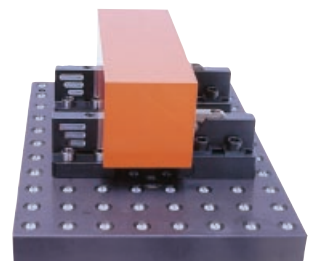

Perforated palette with down draw clamps (see main catalogue)

Module plates - Examples for multiple applications

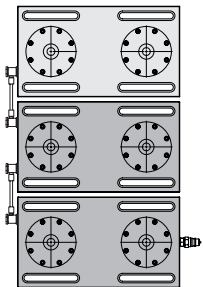

3 module plates



1 perforated palette with
down draw clamps

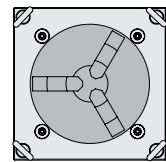

1 jaw chuck palette



2 perforated pallet with
down draw clamps

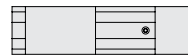
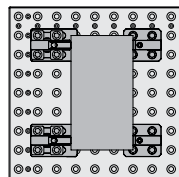

3 vises

Setting-up the SPEEDY module plate – quick and easy

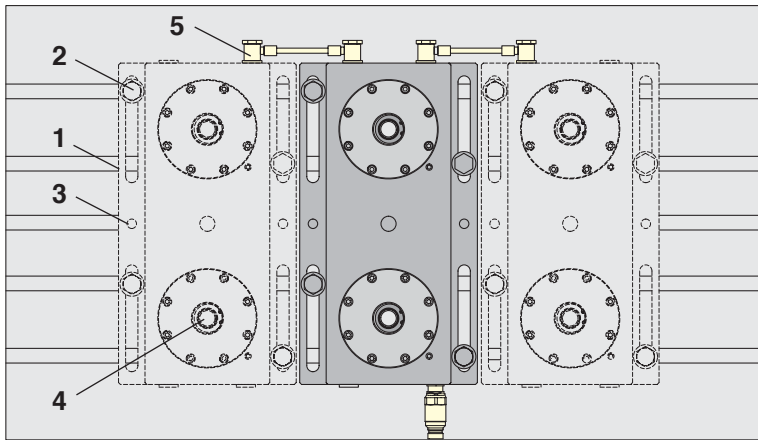

1. Align and screw on the SPPEEDY module plate (1). Alignment also possible with the sliding block with pin (3) and positioning pin.
2. Move the positioning pin to the zero point (4).
3. With hole gauge (200mm), set the second and third module plates at the right or left.
4. Install the hydraulics (5).

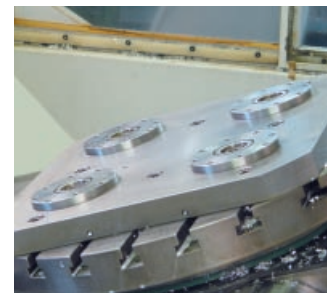
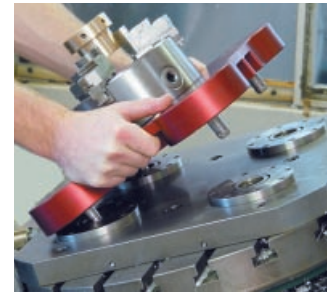
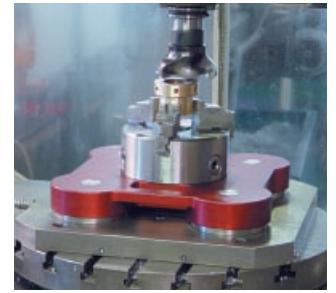

SPEEDY module plates – a Stark innovation

- A low-cost entry into the clamping technology
- Flexible and module extensions
- Mountable on any machine table (machine independent)
- Significant savings in setting-up
- External setting-up extends machine production cycles



The success multipliers - SPEEDY module plates guarantee increased efficiency in production

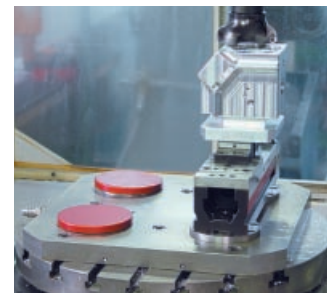

Synergies of Core Competences

We are members of the ROEMHELD Group and our customers benefit from the synergies created by our cooperation with other competent technology companies. The ROEMHELD Group is globally oriented and serves industrial customers all around the world.



STARK

Zero point mounting systems

Stark Spannsysteme GmbH
 Kommingerstrasse 48
 A-6840 Götzis
 Tel.: ++43 (0)5523 64 739-0
 Fax: ++43 (0)5523 64 739-7
 E-Mail: verkauf@stark-inc.com
www.stark-inc.com

 **ROEMHELD**

Power workholding
 Assembly and handling
 techniques
 Linear technics
 Power units

 **HILMA**

Flexible mounting systems
 Machine vice
 Tool power workholding
 Magnetic power work-
 holding

 **FTW**
 Rundtischsysteme

Inovativ round table
 systems

 **FRIEDRICHSHÜTTE**

Grey cast iron and spheroidal-
 graphite cast iron