

Centring clamps

Material:

Body in steel;
bushes in tempered steel

Surface finish:

Black oxide finish

Sample order:

nIm 03165-0615

Note:

The centring clamp allows centring and clamping of a workpiece in the drillhole. The centring clamp has a wide range of movement. The product palette covers a clamping range of $\varnothing 12$ to $\varnothing 30$ mm. In order to increase the precision of the centring, the centring clamp can be fixed in a drillhole with a centring pin (D2).

Centring clamps with internal thread are suitable for matrix system M6 (see application).

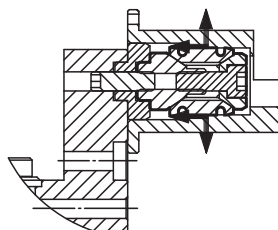
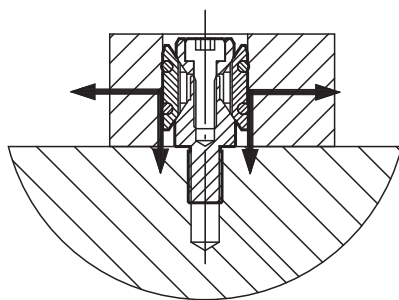
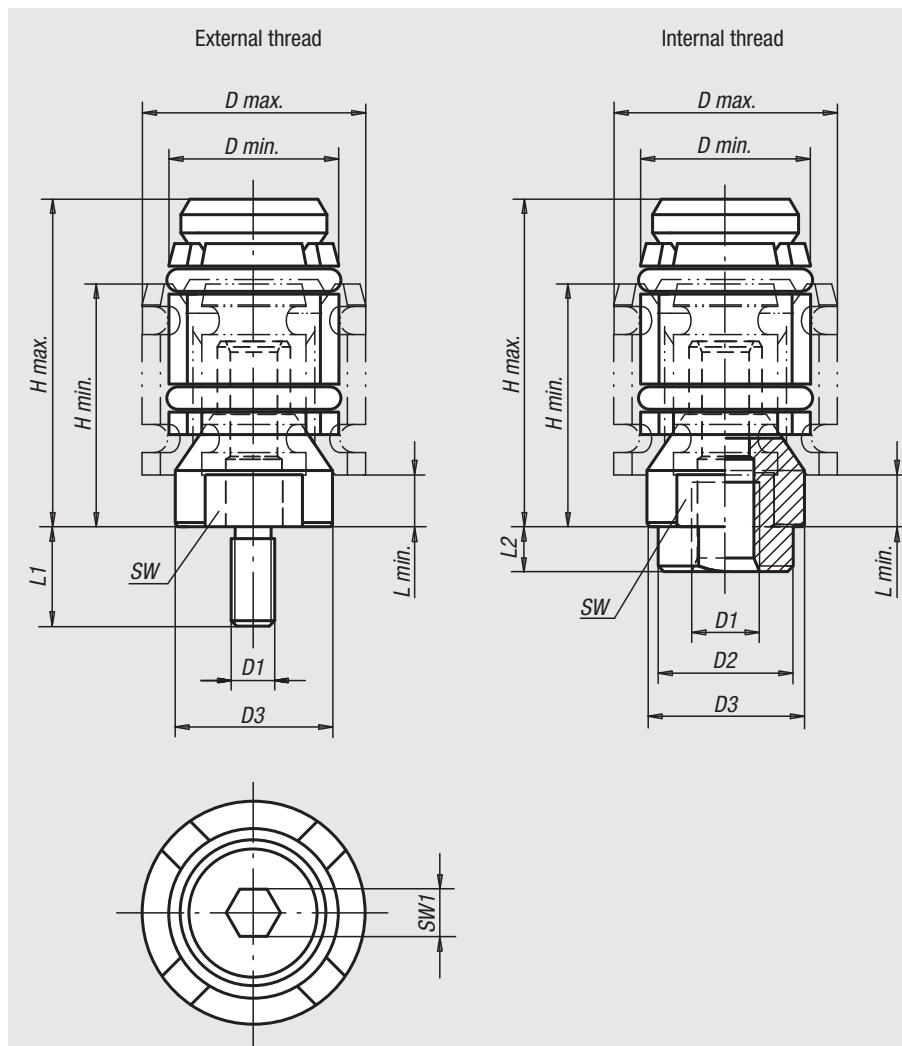

Order No.	Surface finish	D1	L1	L2	D min.	D max.	D2	D3	H min.	H max.	L min.	SW	SW1	Approx. weight kg
03165-0615	Internal thread	M6	-	4	12	15	12	11,4	22	27,5	4,8	9	2,5	0,020
03165-0619	Internal thread	M6	-	4	15	19	12	14	24,5	32	4,8	11	3	0,030
03165-0624	Internal thread	M6	-	4	19	24	12	17,8	26	35	4,5	15	4	0,060
03165-0630	Internal thread	M6	-	4	24	30	12	23,5	32	44,5	7	19	5	0,120
03165-061215	External thread	M6	12	-	12	15	-	11,4	22	27,5	4,8	9	2,5	0,050
03165-061219	External thread	M6	12	-	15	19	-	14	24,5	32	4,8	11	3	0,100
03165-081624	External thread	M8	16	-	19	24	-	17,8	26	35	4,5	15	4	0,150
03165-081630	External thread	M8	16	-	24	30	-	23,5	32	44,5	7	19	5	0,400