

# Flange clamp



**Material:**  
Steel

**Surface finish:**  
Case-hardened, black oxide finish and ground

**Sample order:**  
nlm 04620-23

**Note:**  
The clamping heights can be enlarged by joint bars 04378 and reduced by toggle locators 02000 in the case of 04620-12 to 04620-14 as well as 04620-22 to 04620-24.  
The clamps have the following advantages:  
- rapid clamping by hand via threaded spindle and helical spiral.  
- quick and easy changing of the part for machining by pivoting the clamp away.  
- compact design, therefore little space required for clamping.  
- simple adaptation to even large clamping heights using the vertical cylinders.

The clamps can be affixed in two ways:  
1) in a T-slot.  
2) by the threaded pin M12 directly in the disc of a jig, for example.

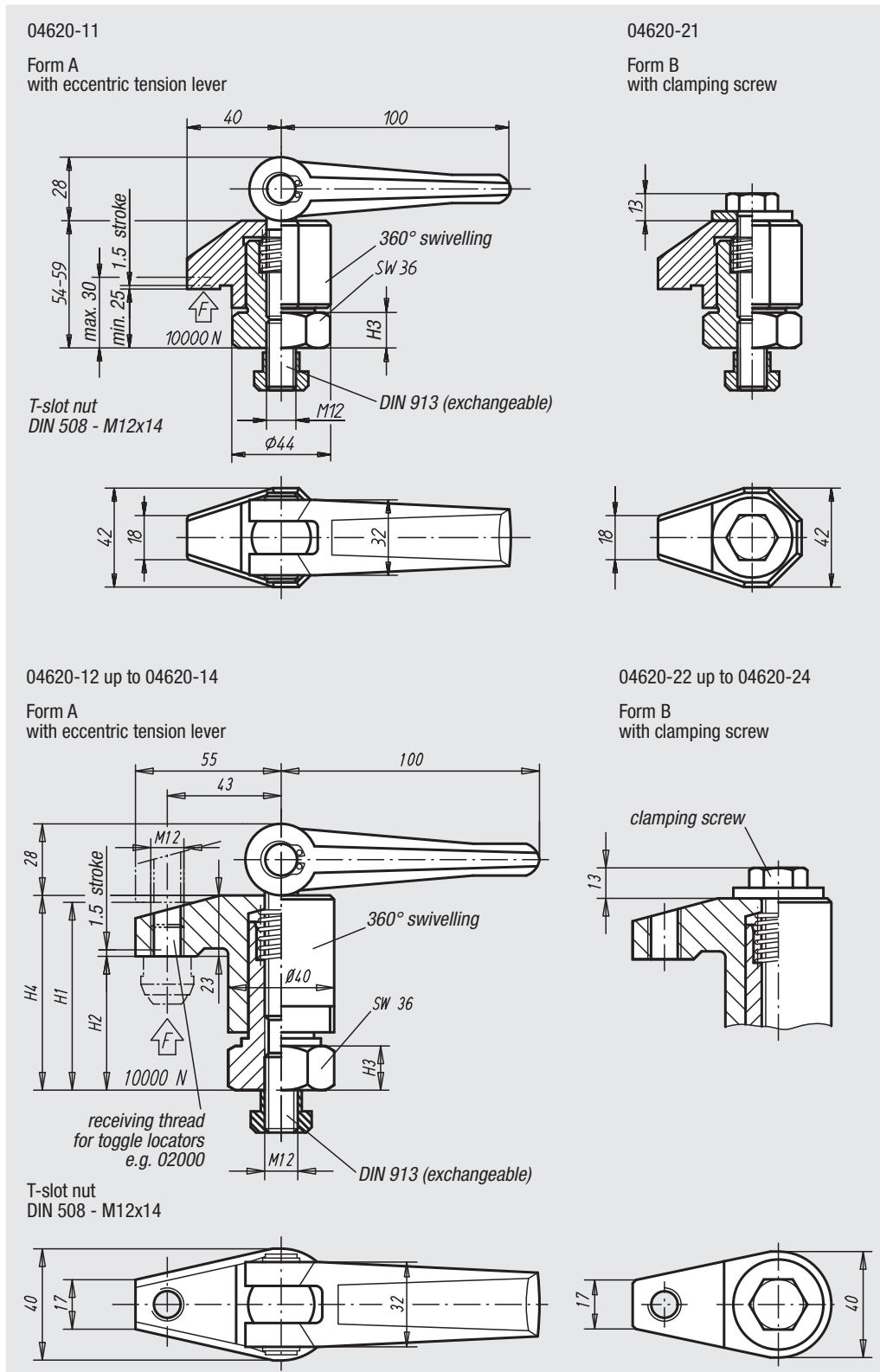
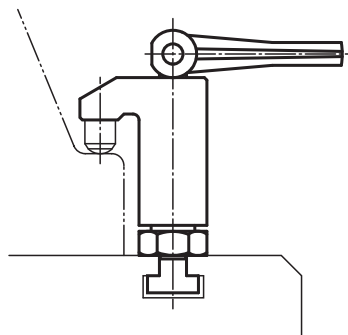

Order No. Form A	Order No. Form B	Clamping height max. H1	Clamping height min. H2	H3	H4
04620-11	04620-21	30	25	15	54-59
04620-12	04620-22	70	50	15	73-93
04620-13	04620-23	98	68	15	91-121
04620-14	04620-24	135	95	22	118-158

01000 02000 03000 04000 05000 06000 07000 08000 09000 20000 21000 22000 23000