

Sliding clamp single-acting

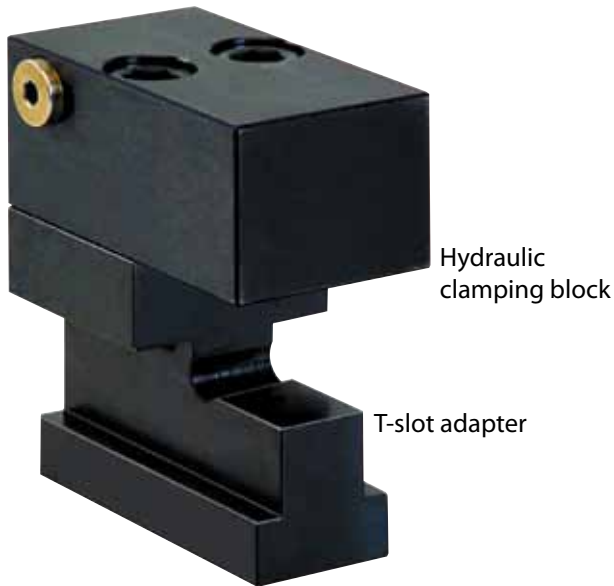

ROEMHELD
HILMA ■ STARK



Hydraulic
clamping block

T-slot adapter

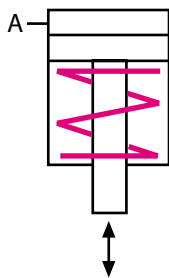

Applications:

- on press beds and rams
- on machines and equipment for clamping and locking
- when the available space is limited
- when temperatures may reach 120° C

Function:

The sliding clamp is manually placed in the T-slot provided in the press ram or bed. The die is clamped on its clamping edge by applying hydraulic pressure to the piston and mechanically unclamped by spring return. The clamping block may also be fastened directly, without a T-slot adapter.

Special features:

- ◇ ideal power transmission
- ◇ compact design
- ◇ clamping force of between 19 and 78 kN
- ◇ easy fastening
- ◇ compensates for large clamping edge tolerances
- ◇ no colliding edges, smooth die positioning
- ◇ suitable for retrofit
- ◇ no need for die standardisation (width and depth)

For power units
please refer to product group 7

For accessories
please refer to product group 11

Recommended accessories:
Angular rotary coupling
Part no. 9208-043

Sliding
clamps

Sliding clamps fastened to bed and ram
of a double column press. Dies are
entered from the front using consoles.





Sliding clamp single-acting

Sliding clamp complete

T-slot (mm)	Clamping force (kN)	Part no.	Dim. 'f' min.	Dim. 'f' max.
18	19,2	8.2202.1850	42	90
22	19,2	8.2202.2250	50	106
22	32	8.2203.2250	50	106
22	50	8.2204.2250	50	106
28	32	8.2203.2850	55	106
28	50	8.2204.2850	55	112
28	78	8.2205.2850	60	117

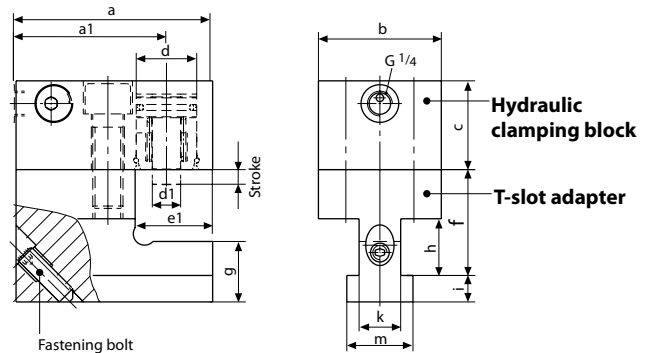

Example of ordering: 8.2202.1850/ F60

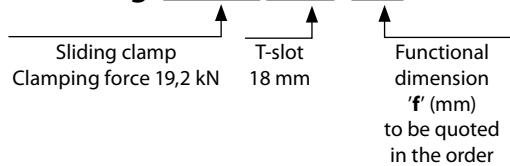

Functional dimension 'f':

$\frac{1}{2}$ stroke
+ height of die clamping edge
+ web height of T-slot
= dimension 'f'

T-slot as per DIN 650 (mm)	18	22	22	22	28	28	28
Clamping force at 400 bar (kN)	19,2	19,2	32	50	32	50	78
Stroke (mm)	8	8	8	8	8	8	12
Oil consumption (cm ³)	4	4	7	10	7	10	24
a (mm)	95	95	104	111	104	111	132
a1 (mm)	77	77	81	85	81	85	99
b (mm)	65	65	65	65	65	65	80
c (mm)	40	40	47	50	47	50	75
d (mm)	25	25	32	40	32	40	50
d1 (mm)	15	15	15	20	15	20	25
e (mm)	23	23	28	31	28	31	38
e1 (mm)	32	32	41	48	41	48	60
g (mm)	24	32	32	32	42	42	42
h (mm)	25	30	30	30	37	37	37
i (mm)	10	14	14	14	18	18	18
k (mm)	18	22	22	22	28	28	28
m (mm)	28	35	35	35	44	44	44
Weight (kg)	2,9	3,2	3,6	3,9	4,2	4,5	7,5

max. operating pressure 400 bar

Please consult us if aggressive spray is used

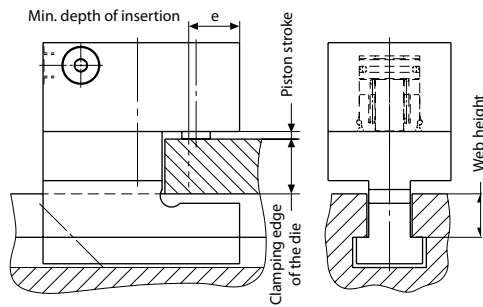

Parking station accommodates the clamping element during die change

T-slot as per DIN 650 (mm)	18	22	28
a (mm)	25	33	43
k (mm)	30	37	46
i (mm)	10	14	18
g (mm)	24	32	42
Parking station complete with holder and ledge			
Part no.	8.2754.1850	8.2754.2250	8.2754.2850
Holder Part no.	2754-180	2754-220	2754-280
Spacer ledge Part no.	2754-500	2754-500	2754-500

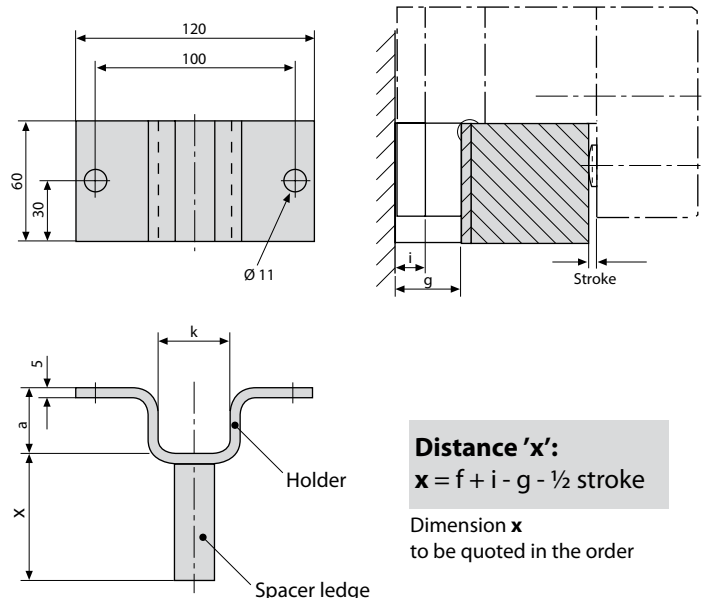

Distance 'x':
 $x = f + i - g - \frac{1}{2}$ stroke

Dimension x to be quoted in the order

For suitable **power units** please refer to product group 7
For **hydraulic hoses** please refer to product group 11

Clamping block - Sliding clamp single-acting with spring return



ROEMHELD
HILMA ■ STARK

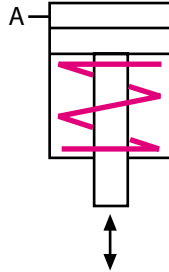
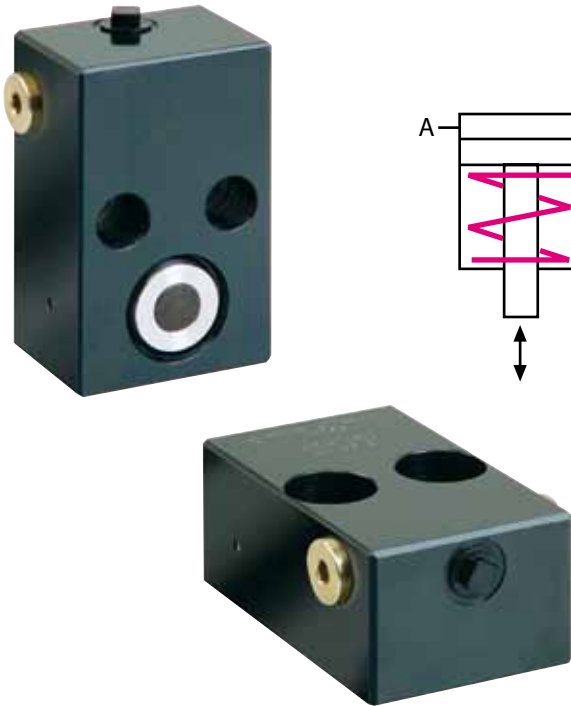

Applications:

- on press beds and rams
- on machines and equipment for clamping and locking
- when the available space is limited

Function:

The workpiece is clamped on its clamping edge by applying hydraulic pressure to the piston and mechanically unclamped by spring return. The clamping block may be fastened by screwing it to stationary spacer ledges or in combination with a T-slot adapter for clamping workpieces in the T-slots of a press bed or ram.

Hydraulic clamping block without T-slot adapter

Clamping force at 400 bar (kN)	19,2	32	50	78
Stroke (mm)	8	8	8	12
Oil cons. (cm ³)	4	7	10	24
a (mm)	95	104	111	132
a1 (mm)	77	81	85	99
b (mm)	65	65	65	80
c (mm)	40	47	50	75
d (mm)	25	32	40	50
d1 (mm)	15	15	20	25
m (mm)	24	29	32	53
n (mm)	M 16	M 16	M 16	M 20
o (mm)	18	20	20	28
p (mm)	36	36	36	43
r (mm)	50	50	50	57
s (mm)	12,0	15,0	16,5	22,0
Weight (kg)	1,6	2,0	2,3	4,9
Part no.	8.2202.1301	8.2203.1301	8.2204.1301	8.2205.1301

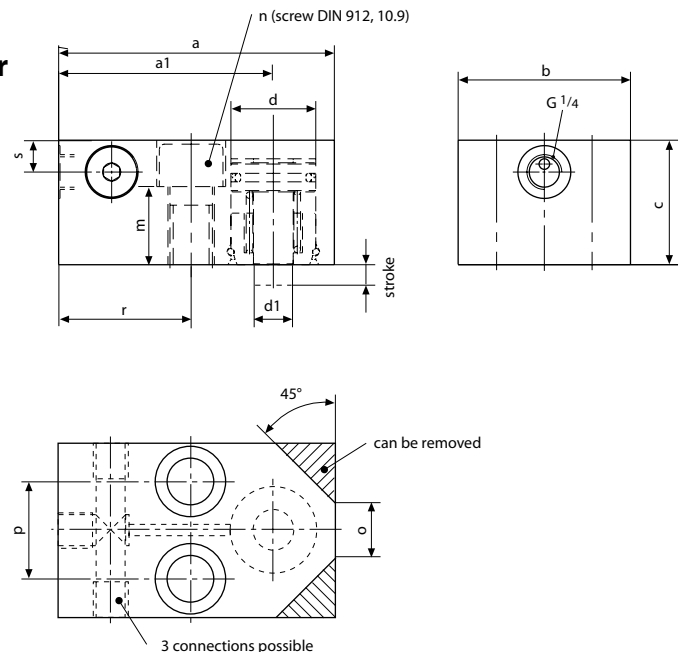

max. operating pressure: 400 bar.
Fastening screws M16 or M20, DIN 912, 10.9 are not included.