



Block Cylinder with Guide Housing

max. operating pressure 500 bar, extending 500 bar steel block cylinder, 350 bar aluminium block cylinder, retracting 350 bar all versions



Advantages

- 4 sizes with different strokes
- 3 block cylinder variants with and without position monitoring
- Standard FKM seals
- Max. environmental temperature as per version up to 150 °C
- Position monitoring up to 120 °C environmental temperature (see accessories)
- Separation of the function “force generation” and “guiding”
- Clamping bolt compensates high transverse forces
- Clamping bolts can be greased
- Cylinder piston protected by guide housing
- Guide housing protected by sturdy wiper
- The distance of the block cylinder to the effective point allows application in more arduous applications, e.g. welding fixtures
- Hydraulic ports and position monitoring can be mounted at the right-hand side or at the left-hand side

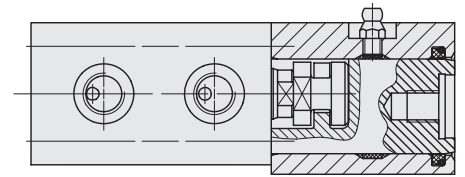

Description

The hardened clamping bolt is located in a guide housing, and is connected to the flange-mounted block-cylinder by means of a coupling.

The following variants are available

1. Block cylinder as per data sheet B 1.509 without position monitoring
2. Block cylinder as per data sheet B 1.552 with extended piston rod for position monitoring with inductive proximity switches.
3. Block cylinder as per data sheet B 1.554 with magnetic piston and aluminium housing for position monitoring with magnetic sensors.

Variants

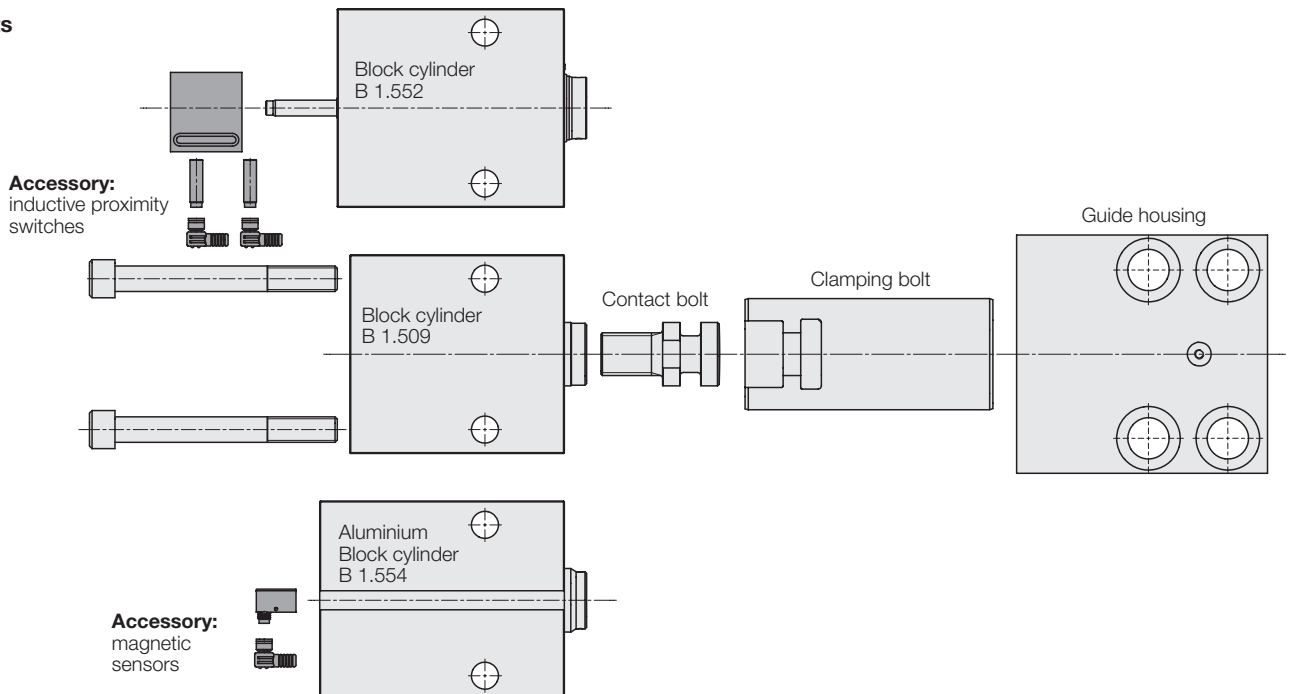

Dimensions block cylinder with guide housing

Block cylinder as per data sheet B 1.552 with extended piston rod and guide housing

Accessory: position monitoring see page 4

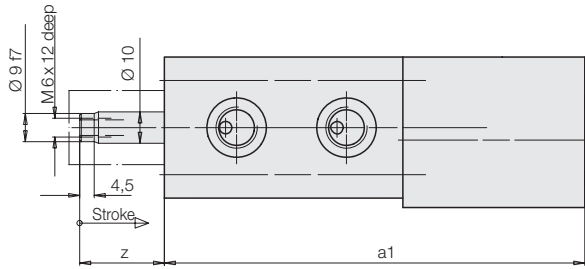

Max. operating pressure
Extend 500 bar
Retract 350 bar

Block cylinder as per data sheet B 1.509 with guide housing

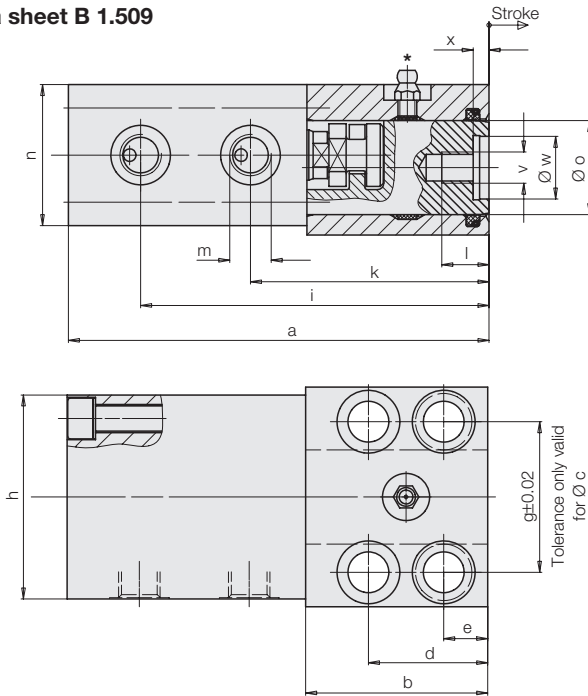

only for 1738-03X and 1738-06X

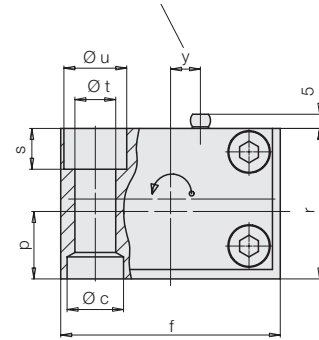

The block cylinder can be turned by 180°

Max. operating pressure
Extend 500 bar
Retract 350 bar

Aluminium block cylinder as per data sheet B 1.554 with guide housing

Accessory: magnetic sensors see page 5

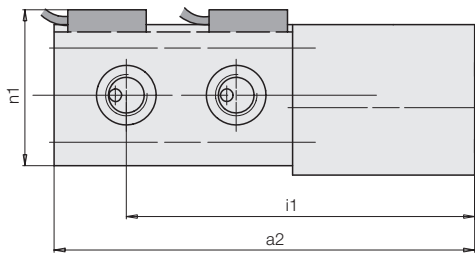

Max. operating pressure 350 bar

Important notes

1. All variants

The guide housing is equipped with a lubricating nipple, so that the clamping bolts can be lubricated with high-temperature grease according to the operating conditions. For this purpose the clamping bolt must be retracted in off-position. Lubrication intervals must be adapted to existing operating conditions.

- Throttling of the flow rate

Throttling has to be made in the oil supply line to the block cylinder to rule out a possible pressure intensification and thereby pressures over 350 bar. The hydraulic circuit diagram shows flow control valves which allow oil return from the block cylinder without any impediments.

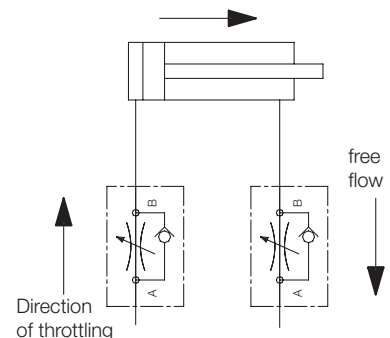

Dimensions block cylinder with guide housing

Piston Ø	[mm]	25	25	40	40	50	50	63	63
Stroke	[mm]	20	50	25	50	25	50	30	63
a	[mm]	122	182	157	207	190	240	227	293
a1	[mm]	134	194	168	218	200	250	235	-
a2	[mm]	136	196	174	224	207	257	246	312
b	[mm]	58	88	78	103	100	125	125	158
Ø c H7x depth	[mm]	18/7	18/7	26/9	26/9	30/11	30/11	35/11	35/11
d	[mm]	38	38	46	46	58	58	75	75
e	[mm]	14	14	16	16	20	20	25	25
f	[mm]	70	70	95	95	120	120	150	150
g	[mm]	48	48	65	65	85	85	106	106
h	[mm]	65	65	85	85	100	100	125	125
i	[mm]	111	171	146	196	177	227	210	276
i1	[mm]	118	178	153	203	186	236	220	286
k	[mm]	76	106	102	127	127	152	151	184
l	[mm]	18	18	25	25	30	30	40	40
m		G 1/4	G 1/4	G 1/4	G 1/4	G 1/4	G 1/4	G 1/2	G 1/2
n	[mm]	45	45	63	63	75	75	95	95
n1	[mm]	57	57	75	75	87	87	107	107
Ø o	[mm]	30	30	40	40	55	55	70	70
p	[mm]	21.5	21.5	28	28	37	37	49	49
r	[mm]	48	48	65	65	80	80	105	105
s	[mm]	13	13	18	18	20	20	25,5	25,5
Ø t	[mm]	13	13	17	17	21	21	26	26
Ø u	[mm]	20	20	26	26	32	32	40	40
v	[mm]	M 10	M 10	M 16	M 16	M 20	M 20	M 27	M 27
Ø w H7	[mm]	20	20	32	32	40	40	50	50
x	[mm]	5	5	5	5	5	5	5	5
y	[mm]	9,5	9,5	-	-	19	19	-	-
z	[mm]	27	57	32	57	32	57	37	-
4 off screws DIN 912-8.8*	[mm]	M 12	M 12	M 16	M 16	M 20	M 20	M 24	M 24
Required tightening torque	[Nm]	86	86	210	210	410	410	710	710
Accessory , for drill bushing DIN 179	[mm]	A 12 x 12	A 12 x 12	A 17 x 16	A 17 x 16	A 21 x 20	A 21 x 20	A 26 x 20	A 26 x 20
Part-no.		3300-285	3300-285	3300-287	3300-287	3300-288	3300-288	3300-289	3300-289

Block cylinder with extended piston rod and guide housing

Part-no.		1738-330	1738-336	1738-350	1738-356	1738-360	1738-366	1738-370	
Max. clamping force at 500 bar F	[kN]	20.6	20.6	58.9	58.9	94.2	94.2	152	
Weight	[kg]	2.5	3.9	5.7	7.7	7.6	10.5	14.8	

Accessory, position monitoring see page 4

Block cylinder with guide housing

Part-no.		1738-030	1738-036	1738-050	1738-056	1738-060	1738-066	1738-070	1738-076
Max. clamping force at 500 bar F	[kN]	24.5	24.5	62.8	62.8	98.5	98.5	156	156
Weight	[kg]	2.4	3.8	5.6	7.6	7.5	10.4	14.7	20.8

Aluminium block cylinder with guide housing

Part-no.		1738-130	1738-136	1738-150	1738-156	1738-160	1738-166	1738-170	1738-176
Max. clamping force at 350 bar F	[kN]	17.1	17.1	44	44	68.7	68.7	109.2	109.2
Weight	[kg]	2.14	2.36	4.4	5.9	5.74	8.05	12	16.1

Accessory, magnetic sensors see page 5

* included in the delivery

2. Block cylinder with extended piston rod

Inductive position monitoring systems, which can be delivered as accessory, are not suitable for applications where coolants are used. Additional covers also have to be provided against swarf.

3. Block cylinder with aluminium housing

Please use only fittings with soft seals (see accessories page 5).

Block cylinders with aluminium housing are not suitable for operation of blanking and punching dies. Uncontrollable spikes and vibrations can appear which especially in the case of aluminium could cause a decrease in tool life.

Steel can influence the magnetic field of the magnetic piston and thereby the position of the switching points. If there is the same influence for each stroke (e.g. because of

adjoining steel components) it can be compensated by displacing the magnetic sensors. But if the influence differs from stroke to stroke, as e.g. in the case of swarf, a cover has to be provided 30mm over the magnetic sensors. Covers have to be provided to protect the cylinders against ferritic swarf.

Accessory: Position monitoring

Description

The position monitoring will be screwed on the cylinder bottom and can also be mounted in a position rotated by 180°. Different versions are available according to the application conditions. A control cam is provided at the extended piston rod causing the activation of the proximity switches. The adjustment of the switching position is effected by a displacement of the proximity switches in the lateral groove. The proximity switches are switched on in a stroke range of approx. 6 mm by means of the control cam. The minimum distance to the positions to be monitored depends on the switch type and is indicated in the table.

Function

1. Signal – unclamped position, i.e. piston rod is retracted
2. Signal – clamped position, i.e. piston rod is extended and is in the clamped area

Important notes

The position monitoring system is not suitable for applications where coolants are used. Additional covers also have to be provided against swarf.

Designing – Application Conditions – Safety Measures

Careful design is required, the corresponding application conditions and safety measures have to be planned and guaranteed.

Please do not hesitate to contact us for further information.

Electric circuit diagram

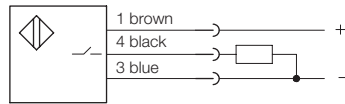

Technical data for inductive proximity switches

Voltage UB	10 ... 30 VDC
Ripple	max. 15%
Switching function	closing
Basic technology	PNP
Material of housing	stainless steel
Code class according to DIN 40050	IP 67

Type A

Standard version

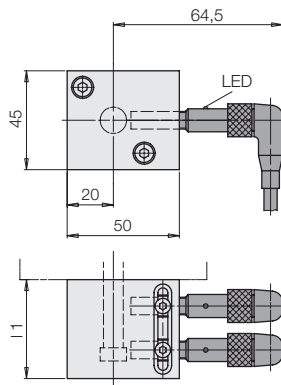

Type B

Compact version

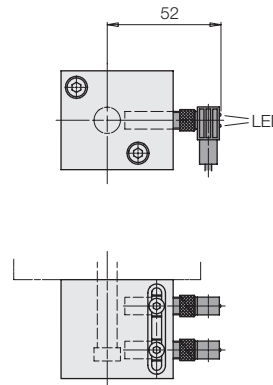

Type C

for high environmental temperature

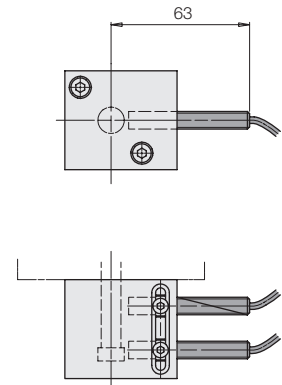

	Type A	Type B	Type C
Environmental temperature TA	-25° ... +70°C	-25° ... +70°C	-25° ... +120°C
Min. distance of the switching positions [mm]	13	8	8
Connection type	Plug	Plug	Teflon cable 3 x 0.14 mm ²
LED function display	in the switch	in the plug	No
Max. constant current [mA]	200	100	200 – off 70°:100
Nominal switch distance [mm]	1.5	1.5	2
Short circuit proof	Yes	Yes	No
Connection cable [m]	5	5	3
Proximity switch	Part-no. 3829-077	3829-263	3829-087
Plug with cable	Part-no. 3829-088	3829-099	–
L1 complete [mm]	45	45	45
Position monitoring up to 30 mm total stroke	Part-no. 0382-300	0382-301	0382-302
L1 complete [mm]	65	65	65
Position monitoring up to 50 mm total stroke	Part-no. 0382-310	0382-311	0382-312

Position monitoring without proximity switches

In case of use of own inductive proximity switches the switching unit M 8x1 is also available without proximity switches.

Required dimensions

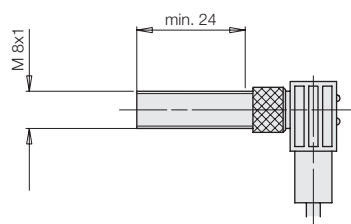

	Part-no.
Total stroke [mm] up to 30	0382-303
Total stroke [mm] up to 50	0382-313

Accessory: Magnetic sensors

Compared with traditional reed switches the electronic magnetic sensors offer the following advantages:

- Indifference to shock and vibration
- Bounce-free output signal
- Only one switching point
- Wear resistant
- Protection against reverse battery
- Protected against short circuits

Electric connection is made as per traditional inductive proximity switches; up to four magnetic sensors can be connected in series.

Minimum distance of the switching points: 6 mm.

For further information about voltage supply for position controls see data sheet G 2.140.

Electronic magnetic sensor

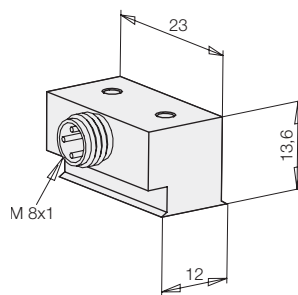

Temperature curve

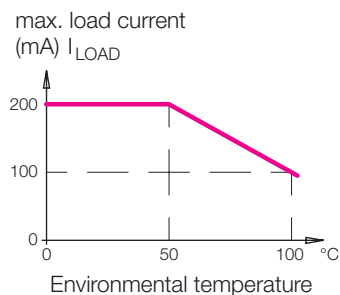

Connecting cable with right angle plug

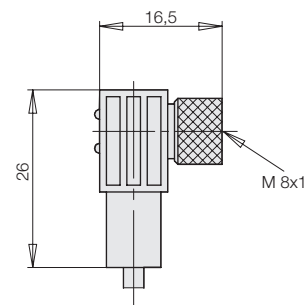

Connecting scheme

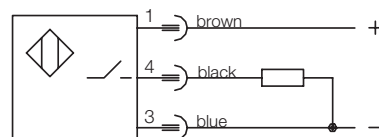

pnp (+) switching

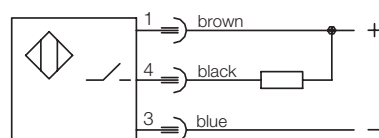

npn (-) switching

Technical characteristics

	Electronic magnetic sensor		Connecting cable with right angle plug	
Cylinder body material	aluminium black lacquered			
Voltage	10 – 30 V DC		10 – 30 V DC	
Residual ripple	max. 10%			
Current load I_{LOAD}	200 mA – up to 50°C 150 mA – at 75°C 100 mA – at 100°C			
Current consumption	< 15 mA			
Voltage drop (max. load)	< 2 V			
Protected against short circuits	yes			
Protection against reverse battery	installed			
Switching frequency	1 kHz			
Switching hysteresis	3 mm			
Protection as per DIN 40050	IP 67		IP 67	
Environmental temperature	–25°C up to +100°C		–25°C up to +90°C	
Plug connection	M8 plug		M8 plug	
LED	no		Voltage (green) Function display (yellow)	
Cable, length of cable			PIR, 5 m	
Output, interlock	pnp	npn	pnp	npn
Part-no. (1 off)	3829-234	3829-240	3829-099	3829-124

Further accessory

see data sheet G 2.140

- Pin-and-socket connector
- Y-distributor
- Reversing plug
- Voltage regulator
- Straight tube male stud coupling with elastic sealing

Type L

D 8 L ED for tube Ø 8 G 1/4 250 bar

D 15 L ED for tube Ø 15 G 1/2 250 bar

Other fittings see data sheet F 9.300

Max. cylinder temperature

Hydraulic fluid	Cylinder temperature	with magnetic sensor	without magnetic sensor	
			Perbunan	FKM
HLP	–25 ... +100 °C		–25 ... +100 °C	–20 ... +120 °C
HFD				–20 ... +120 °C

Part-no.

9208-131

9215-033

Type S

D 8 S ED for tube Ø 8 G 1/4 350 bar

D 16 S ED for tube Ø 16 G 1/2 350 bar

Part-no.

9208-132

9216-021



Coupling fixture

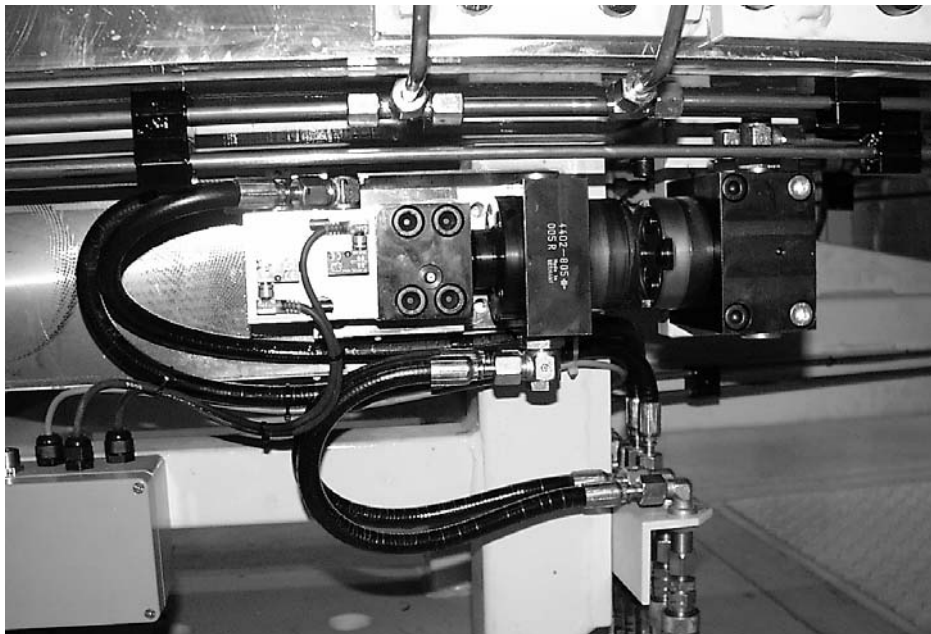

Position monitoring



Position monitoring with inductive proximity switches



Position monitoring
with magnetic sensors