

Filter Housing

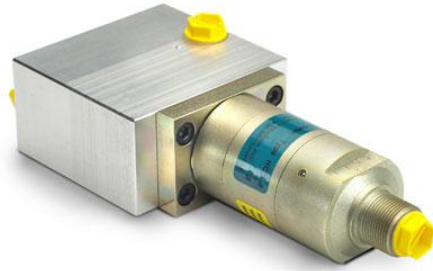

Description

This in-line filter provides protection in hydraulic systems up to 200 bar. It is similar in design and performance to filter models FIL-52T; FIL-53T and FIL-54T with the added advantage that it can be mounted directly on the booster in a very compact assembly. The built-in check valves protect the filter from return flow. The standard bronze element filter is 10 micron.

Operating temperatures: 0°C to 100°C

Dimensions (Filter Housing for HC2- CV6)

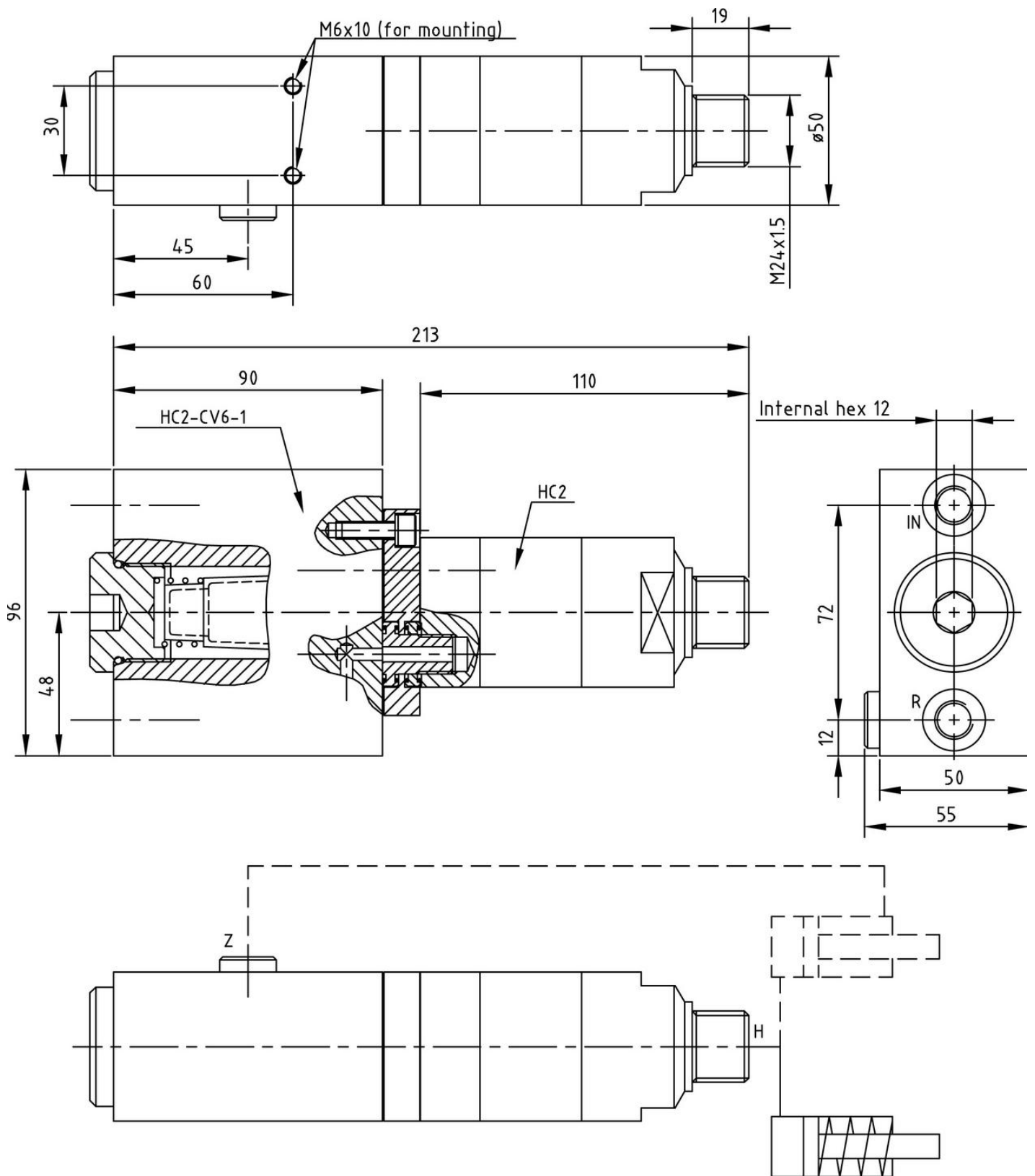

0-311 Model

Dimensions (Filter Housing for HC4- CV6)

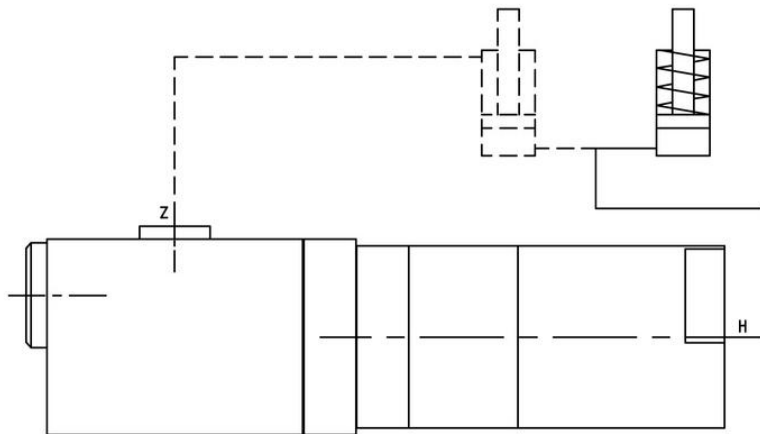
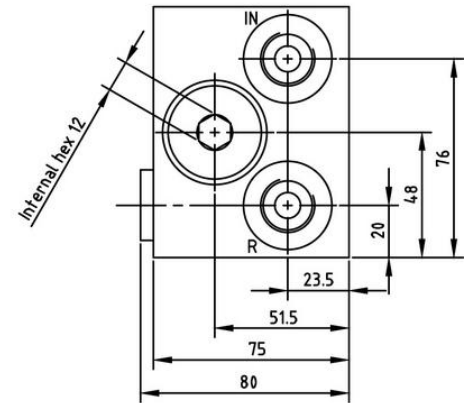
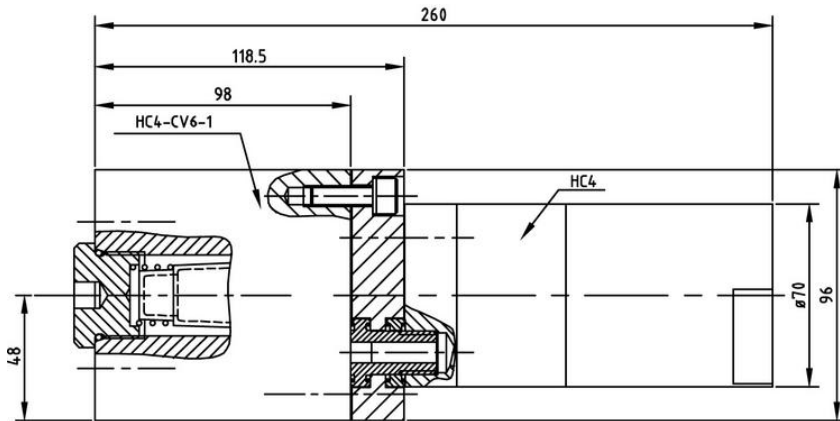
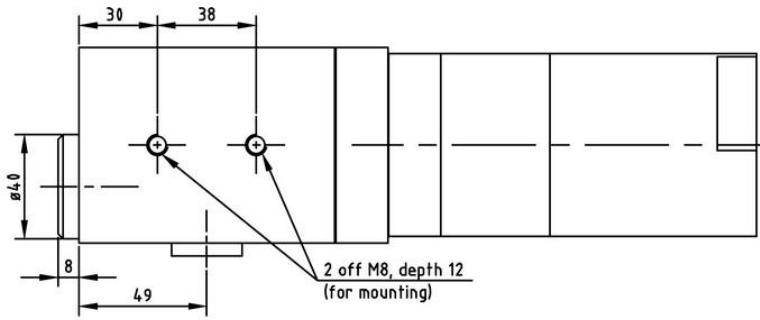

0-316

Dimensions (Filter Housing for HC2D- CV6)

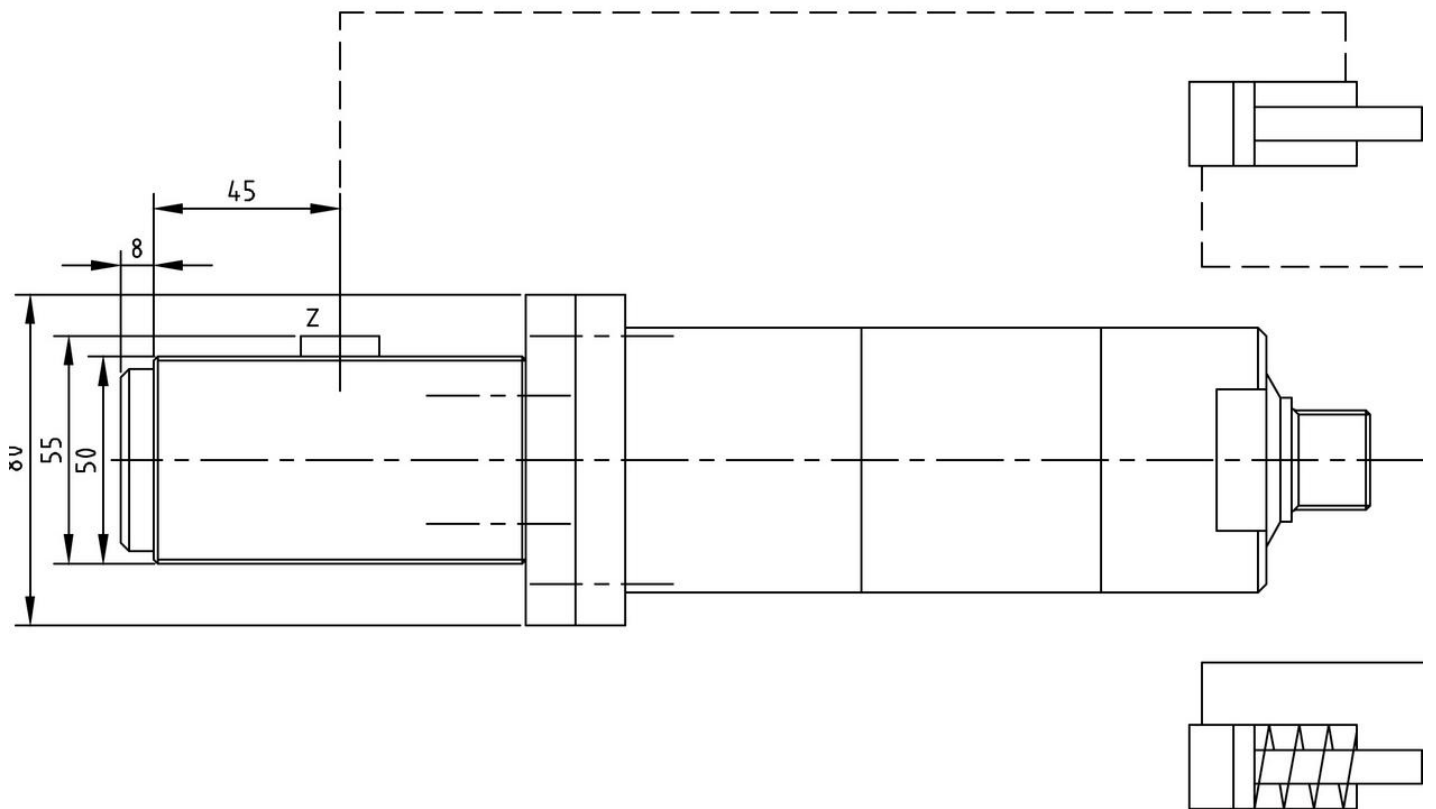
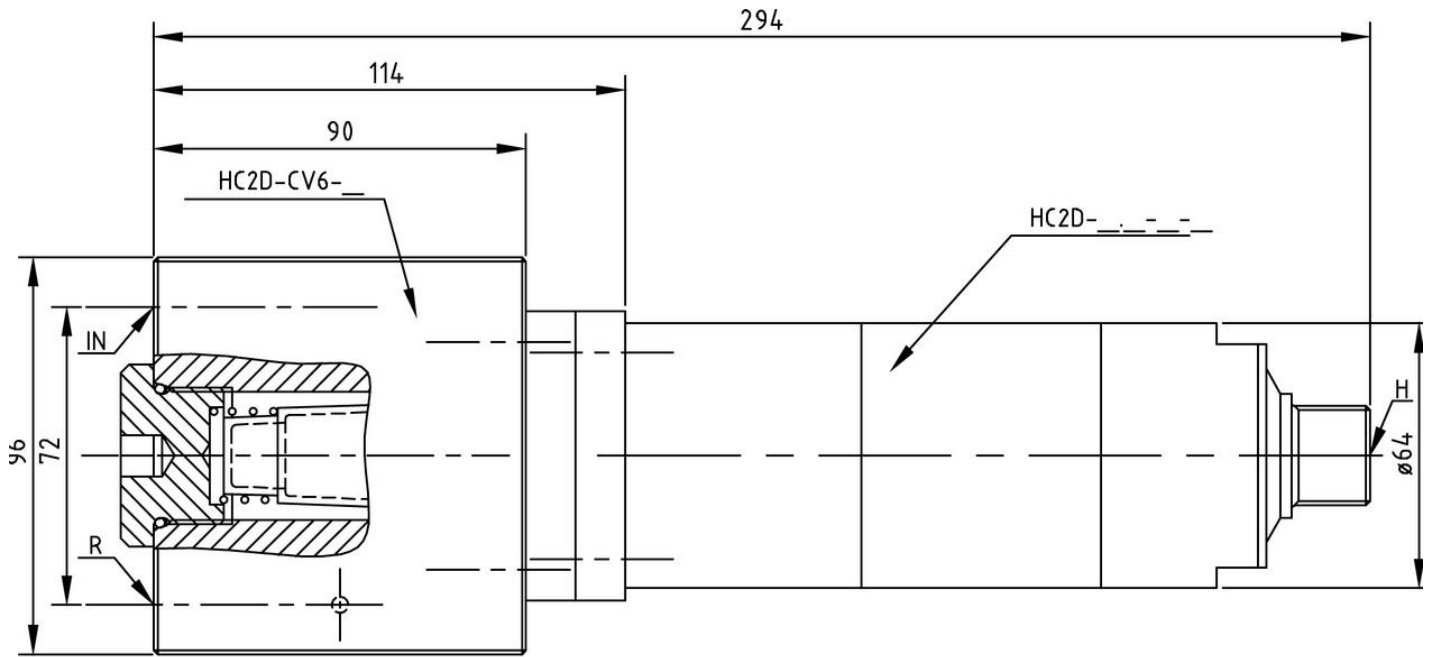

0-343 Model / Issue 01

Dimensions (Filter Housing for HC4- CV7)

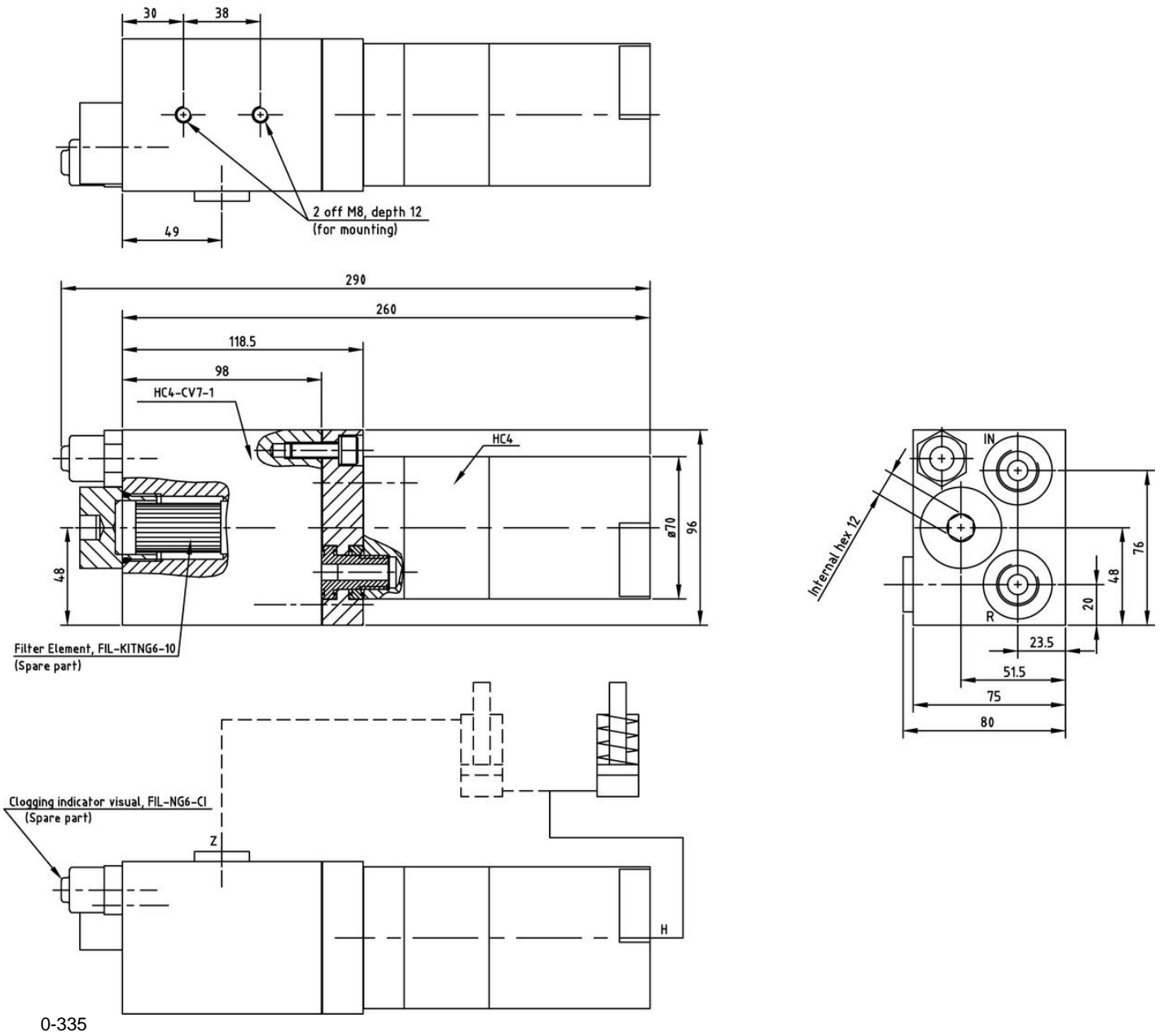

Function diagram

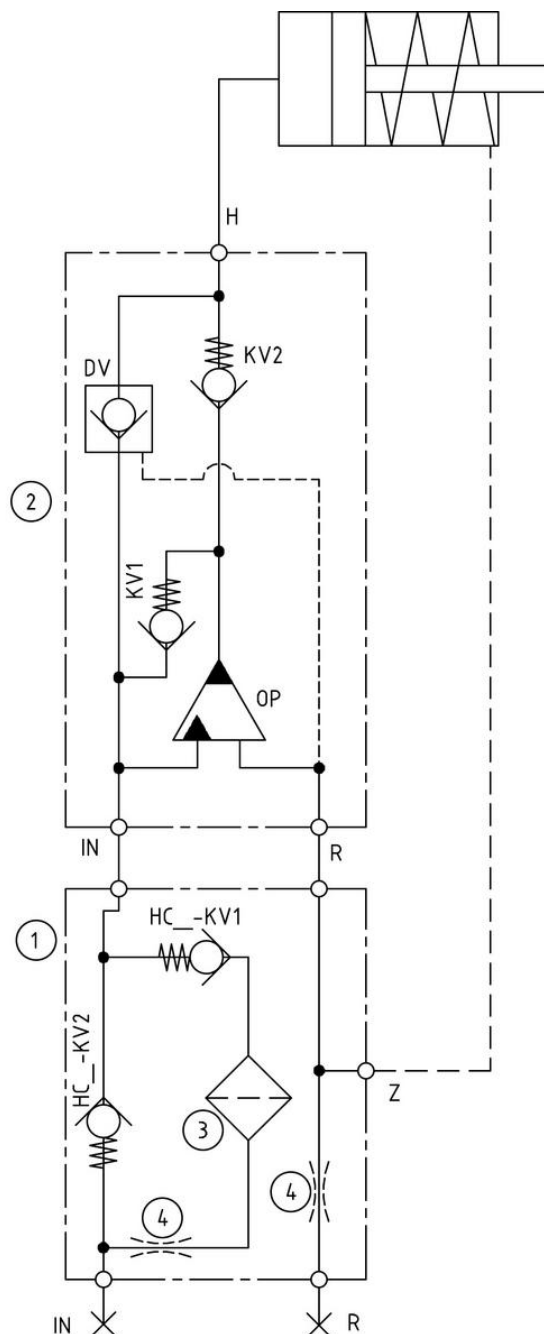

0-208 Model

Ordering

Please note: The set includes a HC2, HC4 Manifold Adapter Kit

Order no.	In / Out	Overall length	Dia.	Weight	Max. pressure	Element and seal
HC2- CV6-1	1/4" BSP	212 mm	96 mm	1.1 kg	200 bar	FIL- KIT-10
HC4- CV6-1	1/2" BSP	212 mm	96 mm	1.8 kg	200 bar	FIL- KIT-10
HC2D- CV6-1	1/4" BSP	294 mm	96 mm	1.5 kg	200 bar	FIL- KIT-10
HC4- CV7-1	1/2" BSP	260 mm	96 mm	2.8 kg	200 bar	FIL- KITNG6-10
FIL- KIT-10	-	-	-	-	-	-