



Swing Clamp with Overload Protection Device
Bottom flange and threaded body,
single and double acting, max. operating pressure 500 bar



Advantages

- 4 sizes each with 3 clamping stroke lengths available
- Bottom flange or threaded mounting
- Pipe thread or drilled channels
- Single or double-acting function
- Standard FKM wiper
- Metallic wiper optional
- Various clamping arms as accessories

Overload protection device

The overload protection device is a spring-loaded disengageable coupling between piston and helix rod that protects the swing mechanism against damage in case of

- blocked swing motion
- too high swing speed
- improper fixing of clamping arm.

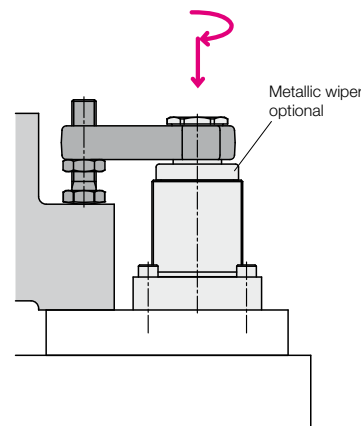

Application

Hydraulic swing clamps are used for clamping of workpieces, when it is essential to keep the clamping area free of straps and clamping components for unrestricted workpiece loading and unloading.

Description

The hydraulic swing clamp is a pull-type cylinder where a part of the total stroke is used to swing the piston.

Swing direction

The units are available with clockwise and counterclockwise swing motion or without swing motion (0°).

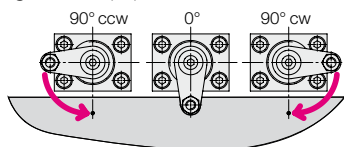

Standard swing angle 90° ± 2°

Optionally swing angles of 60°, 45° and 0° are available.

Further swing angles in steps of 5° are available on request.

0°-Version

Use as pull-type cylinder with a piston which is secured against torsion and which allows eccentric load as per clamping force diagram.

Important notes!

Swing clamps must only be used for clamping of workpieces in industrial applications and may only be operated with hydraulic oil. They can generate very high forces. The workpiece, the fixture or the machine must be in the position to compensate these forces.

In the effective area of piston rod and clamping arm there is the danger of crushing. The manufacturer of the fixture or the machine is obliged to provide effective protection devices. The swing motion must not be impeded to avoid the disengagement of the overload protection device.

When using single-acting swing clamps, it is absolutely necessary to follow the instructions for venting of the spring area see data sheet A 0.110.

Operating conditions, tolerances and other data see data sheet A 0.100.

Installation and connecting possibilities

Pipe thread

Bottom flange

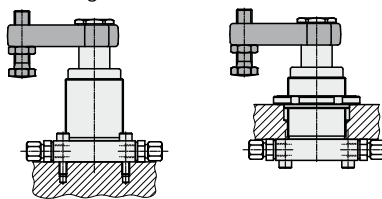

Threaded-body type

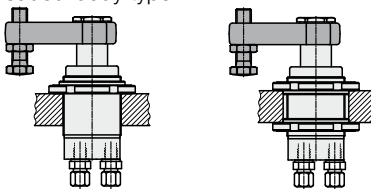

Wiper system see page 6.

Drilled channels

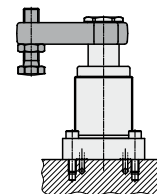

Accessories

Clamping arm with contact bolt (200 bar)

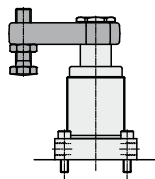

Note: Calculation of the effective clamping force see page 4

Cranked clamping arm (300 bar)

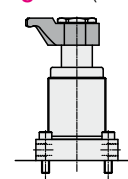

Clamping arm assembly (500 bar)

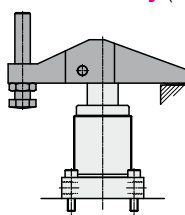

The asymmetric clamping arm assembly is based on a fixed datum. Very high clamping force at 500 bar

Double clamping arm (500 bar)

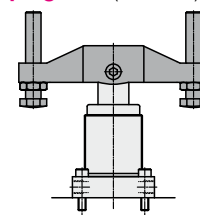

The symmetrical double clamping arm can clamp two workpieces simultaneously, the pulling force of the piston is halved. Built-in spring elements ensure horizontal off-position.

Dimensions

Flange type with pipe thread G 1/4 or with O-ring sealing (see chart)

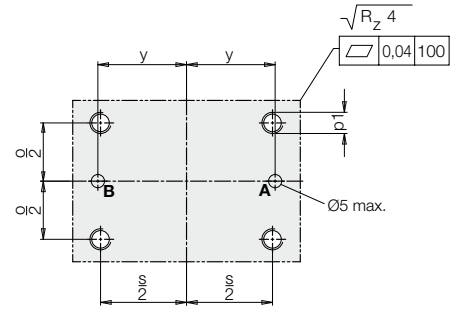
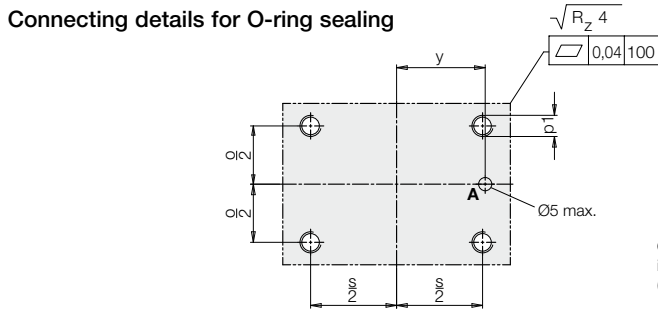
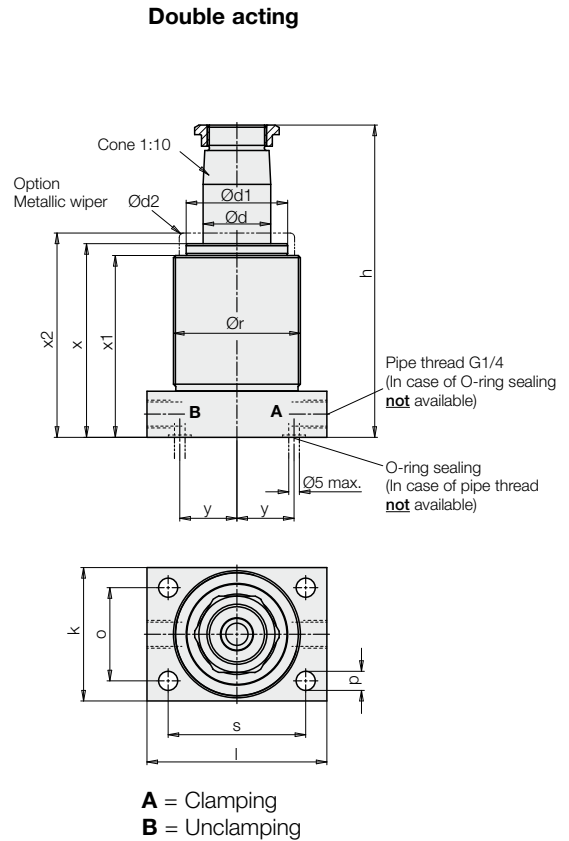
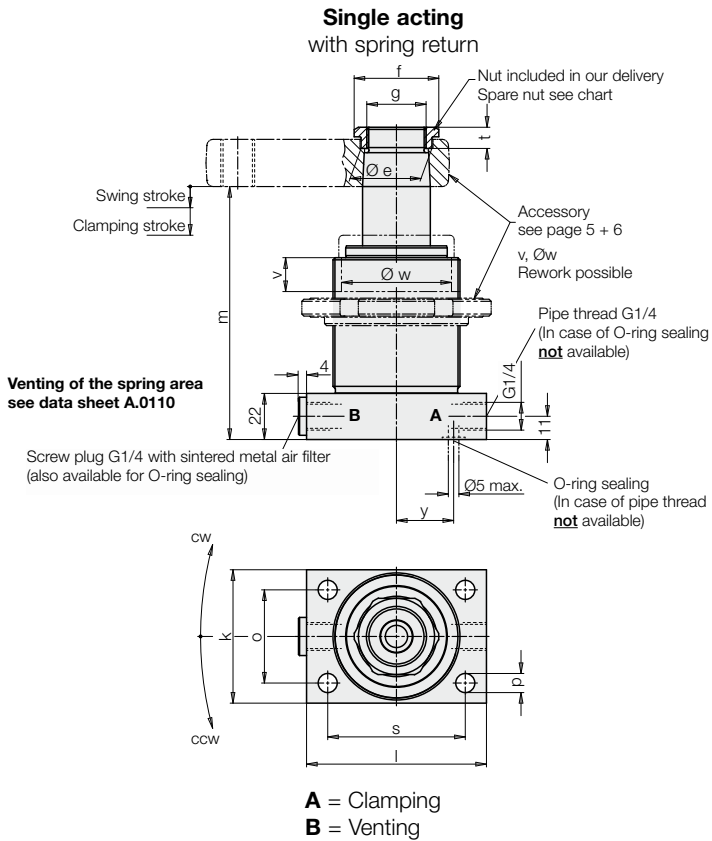

Threaded-body version with pipe thread G 1/4

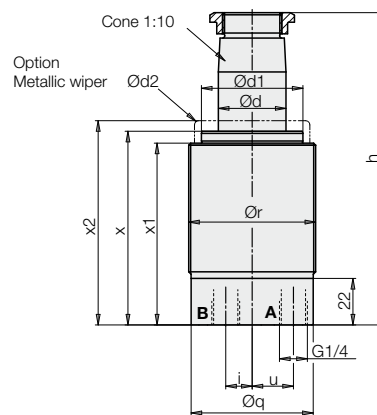
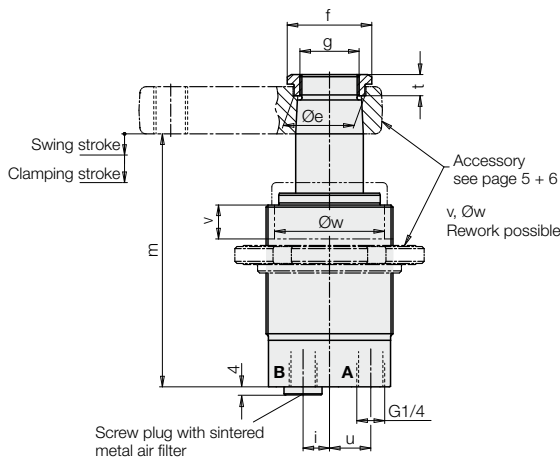

(Venting of the spring area see data sheet A.0110)

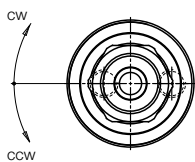

Mounting position

Mounting preferred in vertical position!
Horizontal mounting position is possible with accessory clamping arm (page 5 + 6), but additional flow rate throttling is required to avoid the response of the overload protection device. That is the reason why heavier clamping arms cannot be used!

Material

Piston	High alloy steel, nitrated or chromium-plated to size
Body	High alloy steel, nitrated
Sealings	NBR, PTFE (on request FKM)
Wiper	FKM
Metallic wiper	Nitriding steel

Technical characteristics Part numbers

	18X3			18X5			18X6			18X7		
Swing clamps												
Max. pulling force at 500 bar												
single acting approx. [kN]	8.4			21.4			33.8			55.8		
double-acting approx. [kN]	8.83	8.83	8.83	22.6	22.6	22.6	35.3	35.3	35.3	57.6	57.6	57.6
Effective clamping force [kN]	see diagram and calculation of the clamping force on page 4											
Clamping stroke [mm]	11	25	50	13	25	50	15	25	50	15	25	50
Swing stroke [mm]	8	10	10	9	10	10	11	11	11	10	13	13
Total stroke ± 0.2 [mm]	19	35	60	22	35	60	26	36	61	25	38	63
Declutch moment of overload protection [Nm]	3.5	3.5	3.5	11	11	11	17	17	17	22*/30	30	30
Min. operating pressure												
single acting [bar]	40			40			35			30		
double acting [bar]	20	20	20	20	20	20	20	20	20	20	20	20
Adm. flow rate (page 5)												
Clamping [cm³/s]	3.4	3.4	3.4	10	10	10	18.4	18.4	18.4	29	29	29
Unclamping** [cm³/s]	9.4	9.4	9.4	27.7	27.7	27.7	51	51	51	78	78	78
Piston area												
Clamping [cm²]	1.767			4.524			7.069			11.537		
Unclamping [cm²]	4.909			12.56			19.635			31.172		
Oil volume / stroke												
Clamping [cm³]	3.4	6.2	10.6	10	16	27.2	18.4	25.5	43.2	29	44	73
Unclamping** [cm³]	9.4	17.2	29.5	27.7	44	76	51	71	120	78	119	197
Piston Ø [mm]	25			40			50			63		
Rod Ø d [mm]	20			32			40			50		
Ø d1 [mm]	38			48			60			70		
Ø d2 [mm]	42			54.5			75			87		
Ø e [mm]	23.5			33.5			45			55.5		
f [mm]	SW 27			SW 36			Ø 55			Ø 68		
g [mm]	M18x1.5			M28x1.5			M35x1.5			M45x1.5		
h ± 0.25 [mm]	126.5	158.5	208.5	147.5	173.5	223.5	172	192	242	183	209	259
h max**** [mm]	128.6	160.6	210.6	149.2	175.2	225.2	174.3	194.3	244.3	184.7	210.7	260.7
i [mm]	12			12.5			19			25.5		
k [mm]	45			63			80			90		
l [mm]	65			85			100			115		
m ± 1 [mm]	106.3	138.3	188.3	119.9	145.9	195.9	138.9	158.9	208.9	143.3***	169.3***	219.3***
o [mm]	30			44			60			68		
Ø p [mm]	6.5			8.5			13.5			16		
p1 [mm]	M 6			M 8			M 12			M 14		
Ø q [mm]	42.7			57.7			77			87.5		
r [mm]	M45x1.5			M60x1.5			M80x2			M90x2		
s [mm]	50			65			80			90		
t [mm]	9			10			11			12		
u [mm]	12			19.5			26.5			34		
v max. [mm]	11			17			20			28		
Ø w min.***** [mm]	32/42			50/55			60/75			70/87		
x [mm]	80	96	121	90.5	103.5	128.5	103	113	138	111	124	149
x1 [mm]	75.4	91.4	116.4	84.9	97.9	122.9	97.4	107.4	132.4	105.4	118.4	143.4
x2 +0.5/-0.4 [mm]	85	101	126	95.5	108.5	133.5	108	118	143	116	129	154
y [mm]	15			28			31			37.5		
Flange with G1/4												
Single acting												
Swing direction cw	1883-1X4			1885-1X4			1886-1X4			1887-1X4		
Swing direction ccw	1883-2X4			1885-2X4			1886-2X4			1887-2X4		
Weight, approx. [kg]	1.2			2.4			4.6			6.2		
Double acting												
Swing direction cw	1893-1X4	1893-1X8	1893-1X9	1895-1X4	1895-1X8	1895-1X9	1896-1X4	1896-1X8	1896-1X9	1897-1X4	1897-1X8	1897-1X9
Swing direction ccw	1893-2X4	1893-2X8	1893-2X9	1895-2X4	1895-2X8	1895-2X9	1896-2X4	1896-2X8	1896-2X9	1897-2X4	1897-2X8	1897-2X9
Weight, approx. [kg]	1.2	1.4	1.7	2.3	2.6	3.0	4.5	4.9	5.6	6.2	6.6	7.5
Threaded-body type												
Single acting												
Swing direction cw	1883-3X4			1885-3X4			1886-3X4			1887-3X4		
Swing direction ccw	1883-4X4			1885-4X4			1886-4X4			1887-4X4		
Weight, approx. [kg]	1.0			2.0			4.2			5.6		
Double acting												
Swing direction cw	1893-3X4	1893-3X8	1893-3X9	1895-3X4	1895-3X8	1895-3X9	1896-3X4	1896-3X8	1896-3X9	1897-3X4	1897-3X8	1897-3X9
Swing direction ccw	1893-4X4	1893-4X8	1893-4X9	1895-4X4	1895-4X8	1895-4X9	1896-4X4	1896-4X8	1896-4X9	1897-4X4	1897-4X8	1897-4X9
Weight, approx. [kg]	1.0	1.2	1.4	1.9	2.2	2.6	3.9	4.3	5	5.6	6.0	6.9
Flange with O-ring sealing												
Single acting												
Swing direction cw	1883-5X4			1885-5X4			1886-5X4			1887-5X4		
Swing direction ccw	1883-6X4			1885-6X4			1886-6X4			1887-6X4		
Weight, approx. [kg]	1.2			2.4			4.6			6.2		
Double acting												
Swing direction cw	1893-5X4	1893-5X8	1893-5X9	1895-5X4	1895-5X8	1895-5X9	1896-5X4	1896-5X8	1896-5X9	1897-5X4	1897-5X8	1897-5X9
Swing direction ccw	1893-6X4	1893-6X8	1893-6X9	1895-6X4	1895-6X8	1895-6X9	1896-6X4	1896-6X8	1896-6X9	1897-6X4	1897-6X8	1897-6X9
Weight, approx. [kg]	1.2	1.4	1.7	2.4	2.6	3.0	4.5	4.9	5.6	6.2	6.6	7.5
Spare parts												
Metallic wiper	0341-107			0341-100			0341-101			0341-102		
Spare nut / tightening torque	3527-014/30 Nm			3527-015/90 Nm			3527-048/160 Nm			3527-016/260 Nm		
O-ring 8x1.5	3000-343			3000-343			3000-343			3000-343		

Swing angle	Key	Without swing angle (0°)	Key	
90°	18XX-X0X	Flange with G1/4	18XX-24X	* only single acting
60°	18XX-X2X	Threaded-body type	18XX-44X	** only double acting
45°	18XX-X3X	Flange with O-ring sealing	18XX-64X	*** with clamping arm assembly 0354-004 +3 mm
With metallic wiper	18XX-XXXM (see also page 6)			**** Upper edge nut
				***** without/with metallic wiper

Available on request: • Other swing angles, • FKM seals, • Without overload protection

Clamping forces

Effective clamping force as function of the operating pressure with accessory clamping arm (page 5)

Single acting 188X*

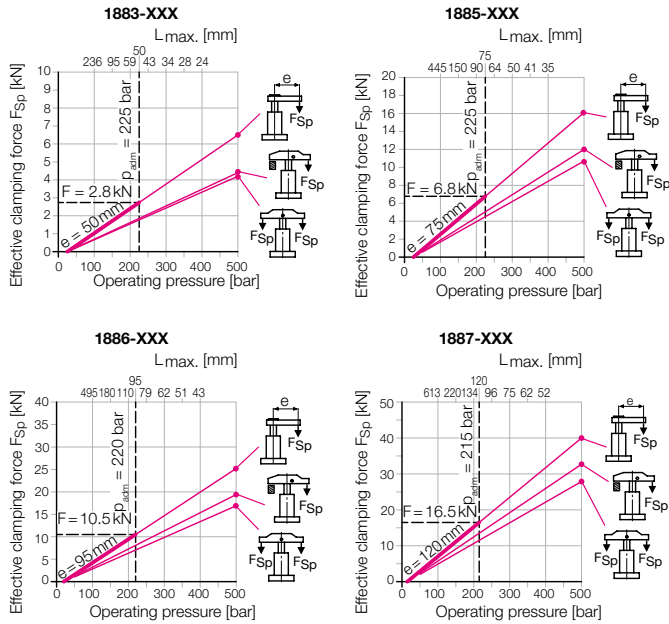

Double acting 189X

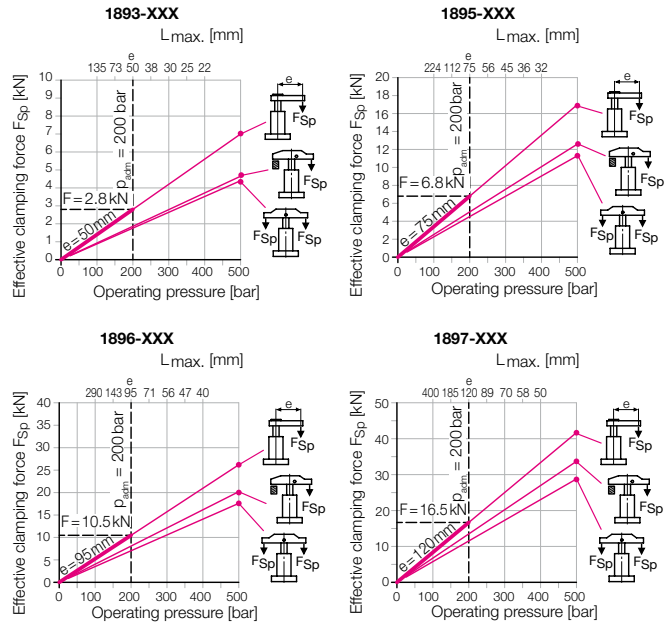

*) In the case of single-acting swing clamps, the spring force has to be considered.

Single-acting swing clamps

Effective clamping force

$$F_{Sp} = \frac{p - F}{A + (B * L)} \leq F_{adm} \quad [\text{kN}]$$

Admissible clamping force *

$$F_{adm} = \frac{C}{L} \quad [\text{kN}]$$

Admissible operating pressure

$$p_{adm} = \frac{D}{L} + E + F \quad [\text{bar}]$$

L = Clamping arm length [mm]
p = Pressure [bar]

*) With a desired clamping arm length L the clamping force must not exceed the admissible value.

The constants (A...F) for the 4 sizes are shown in the chart.

Constant	1883	1885	1886	1887
A	56.59	22.1	14.15	8.67
B	0.297	0.097	0.0514	0.0288
C	140	510	997.5	1980
D	7923	11273	14111	17162
E	41.54	49.7	51.47	57
F	25	25	20	15

Example

Swing clamp single acting 1885-104
Accessory clamping arm e = 75 mm
Desired special length L = 150 mm

1. Admissible clamping force

$$F_{adm} = \frac{C}{L} = \frac{510}{150} = 3.4 \text{ kN}$$

2. Admissible operating pressure

$$p_{adm} = \frac{D}{L} + E + F = \frac{11273}{150} + 49.7 + 25 = 150 \text{ bar}$$

Clamping force diagrams

Course of the effective clamping force for the most important accessories of clamping arms:

- 1. Clamping arm complete (L = e)**
The clamping force can be read off up to the maximum operating pressure. The clamping arm length L_max in the grid of 50 bar only allows for a rough estimate. Exact values and the corresponding clamping forces can be calculated with the opposite formula.
- 2. Clamping strap assembly complete**
clamping force up to 500 bar readable.
- 3. Double clamping arm complete**
Clamping force up to 500 bar corresponds to half the pulling force of the swing clamp.

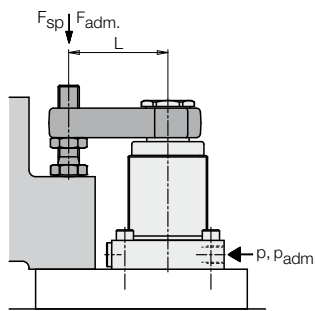

Calculation of the clamping force

The clamping arm of a swing clamp generates a moment and thus a load acts on the piston guide. This additional friction force reduces the clamping force. The longer the clamping arm, the worse is the efficiency. This has been considered in the opposite calculations. The constants were determined by measurements. **Important!** The input of the variables must be made in the specified units.

Double-acting swing clamps

Effective clamping force

$$F_{Sp} = \frac{p}{A + (B * L)} \leq F_{adm} \quad [\text{kN}]$$

Admissible clamping force*

$$F_{adm} = \frac{C}{L} \quad [\text{kN}]$$

Admissible operating pressure

$$p_{adm} = \frac{D}{L} + E \quad [\text{bar}]$$

L = Clamping arm length [mm]
p = Pressure [bar]

*) With a desired clamping arm length L the clamping force must not exceed the admissible value.

The constants (A...E) for the 4 sizes are shown in the chart.

Constant	1893	1895	1896	1897
A	56.59	22.1	14.15	8.67
B	0.297	0.097	0.0514	0.0288
C	140	510	997.5	1980
D	7923	11273	14111	17162
E	41.54	49.7	51.47	57

Example

Swing clamp double acting 1895-104
Accessory clamping arm e = 75 mm
Desired special length L = 150 mm

1. Admissible clamping force

$$F_{adm} = \frac{C}{L} = \frac{510}{150} = 3.4 \text{ kN}$$

2. Admissible operating pressure

$$p_{adm} = \frac{D}{L} + E = \frac{11273}{150} + 49.7 = 125 \text{ bar}$$

Accessory - Clamping Arm Admissible flow rate • Calculation

Dimensions for special clamping arms

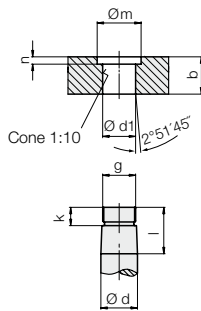

Clamping arm with contact bolt (200 bar)

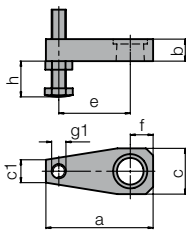

Clamping arm without thread g1

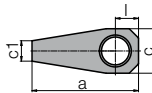

Clamping arm blank

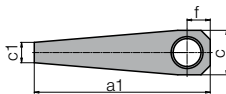

Swing clamps		18X3	18X5	18X6	18X7
a	[mm]	75	115	140	178
a1	[mm]	125	190	235	298
b	[mm]	16	23	28	34
c	[mm]	32	48	60	78
c1	[mm]	16	22	28	40
Ød f7	[mm]	20	32	40	50
Ød1 + 0.05	[mm]	19.85	31.85	39.85	49.85
e	[mm]	50	75	95	120
f	[mm]	16	25	30	40
g	[mm]	M18x1.5	M28x1.5	M35x1.5	M45x1.5
g1	[mm]	M10	M16	M16	M20
h min...max	[mm]	10...64	15...79	15...79	19...98
k	[mm]	10	12	12	13
l	[mm]	21	28	34	40
Øm	[mm]	24	34	46	56
n	[mm]	4	5	5	6

Part-no. Clamping arm

	0354-001	0354-003	0354-042	0354-005
with contact bolt				
Weight, approx. [kg]	0.26	0.8	1.3	2.7
Moment of inertia of J_e [kg·m ²]	0.00032	0.002295	0.005212	0.017184
without thread g1				
Weight, approx. [kg]	0.18	0.65	1.85	2.3
Moment of inertia [kg·m ²]	0.00018	0.00134	0.00387	0.01294
Blank				
Weight, approx. [kg]	0.36	1.15	2.1	4.4
Moment of inertia [kg·m ²]	0.00043	0.00798	0.02343	0.07863

Material: High alloy steel 1000...1200 N/mm²

Admissible flow rate*

In the chart on page 3, the admissible flow rates for clamping and unclamping are specified. They only apply when using the accessory clamping arm with contact bolt. The swing clamps with a clamping stroke up to 15 mm thus have a clamping time of 1 second.

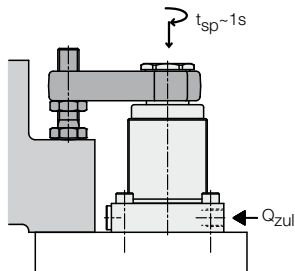

Longer special clamping arms are heavier and have a higher moment of inertia.

To avoid disengagement of the overload protection device, the flow rate must be reduced as per the following formula:

$$Q_L = Q_e \cdot \sqrt{\frac{J_e}{J_L}} \text{ cm}^3/\text{s}$$

Q_L = Flow rate with special clamping arm

Q_e = Flow rate as per chart (page 3)

J_e = Moment of inertia of the clamping arm with contact bolt (see chart)

J_L = Moment of inertia special clamping arm

* Only for vertical mounting position!

Simplified calculation

The special clamping arm is only a prolonged version of the accessory clamping arm with contact bolt, as shown below:

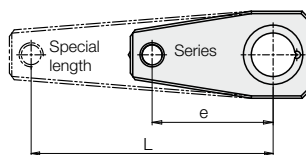

By means of the opposite diagram, the admissible flow rate can be determined, as the following example shows:

Swing clamp 1895-104

Special length $L = 150$ mm

As per chart above $e = 75$ mm

(as per chart on page 3) $Q_{adm} = 10$ cm³/s

1. Extension factor $x = \frac{L}{e} = \frac{150 \text{ mm}}{75 \text{ mm}} = 2$

2. Flow rate factor as per diagram $\rightarrow y = 0.35$

3. Max. flow rate $Q_L = y \cdot Q_{adm} = 0.35 \cdot 10 \text{ cm}^3/\text{s} = 3.5 \text{ cm}^3/\text{s}$

4. Min. clamping time as per diagram \rightarrow approx. 2.8 s

Throttling of the flow rate

A flow rate throttling always has to be effected in the supply line to the swing clamp. This avoids a pressure intensification and thereby pressures exceeding 500 bar.

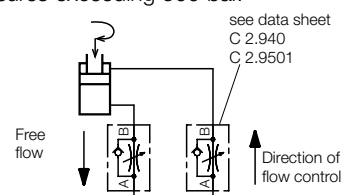

Adm. flow rate and clamping time as a function of the clamping arm extension

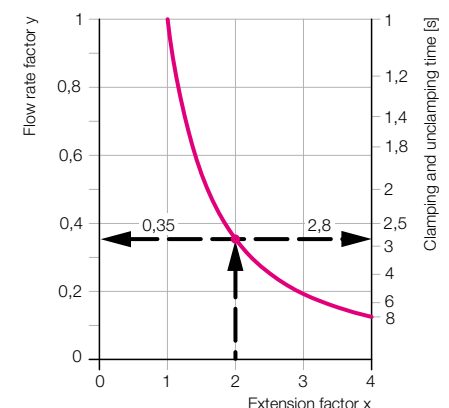

Accessory – Clamping Arm

Clamping arm assembly • Double clamping arm • Flanged nut • Wiper system

Clamping arm short

42CrV4 hardened and tempered
max. 500 bar

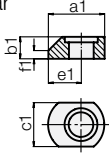

Cranked clamping arm

42CrV4 hardened and tempered
max. 300 bar

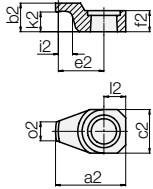

Clamping arm assembly complete with carrier

GGG 40, max. 500 bar

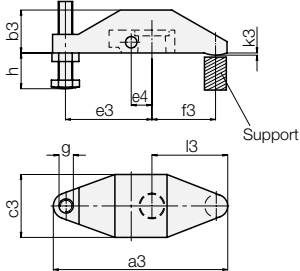

Carrier for clamping arm assembly

42CrV4 hardened and tempered

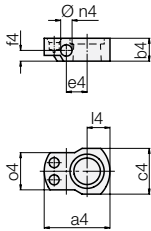

Double clamping arm complete with carrier

GGG 40, max. 500 bar

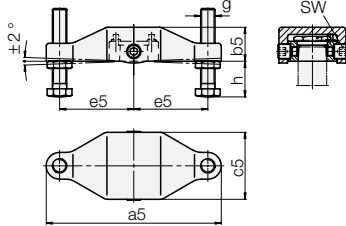

Carrier for double clamping arm

42CrV4 hardened and tempered

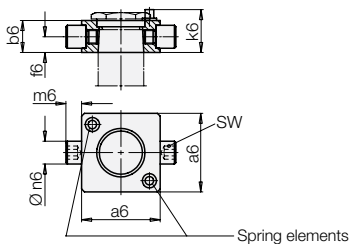

Flanged nut

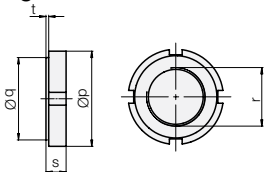

Swing clamps

		18X3	18X5	18X6	18X7
a1	[mm]	41	61	76	90
a2	[mm]	51.5	76	100	123
a3	[mm]	122	185	203	223
a4	[mm]	46	59	82	90
a5	[mm]	138	196	216	236
a6 ±0.1	[mm]	43	55	63	77
b1	[mm]	16	23	28	34
b2	[mm]	21	28	34	40
b3	[mm]	30	45	54	59
b4	[mm]	16	23	28	34
b5	[mm]	28.5	38	47	56
b6	[mm]	16	23	28	34
c1	[mm]	32	48	60	78
c2	[mm]	32	46	66	75
c3	[mm]	44	58.5	82	98
c4	[mm]	32	40	58	68
c5	[mm]	59	75	85	105
e1	[mm]	25	37	45	52
e2	[mm]	33.5	50	64	82.5
e3	[mm]	60	83	92	100
e4	[mm]	14.5	21	28	33
e5	[mm]	60	83	92	100
f1	[mm]	6	6	11	14
f2	[mm]	15.5	22.5	28	34
f3	[mm]	45	75	82	90
f4	[mm]	7.5	13	17	21
f6	[mm]	7.5	11	15	17
g	[mm]	M10	M16	M16	M20
h min...max	[mm]	10...64	15...79	15...79	19...98
i2	[mm]	7	7	7	8
k2	[mm]	14.5	19	23	27
k3	[mm]	1.5	2	2.5	2.5
k6 **	[mm]	21.5	29	35	41
l2	[mm]	16	23	33	37.5
l3	[mm]	53	87	95	105
l4	[mm]	16	22	34	36
m6	[mm]	9	11	12	15
Øn4 H7	[mm]	8	10	12	14
Øn6 g6	[mm]	10	16	18	20
o2	[mm]	14	25	39	39
o4	[mm]	26	32	44.5	56
Øp	[mm]	68	90	115	130
Øq -0.2	[mm]	52	68	90	100
r	[mm]	M45x1.5	M60x1.5	M80x2	M90x2
s	[mm]	12	13	16	16
t	[mm]	3	4	5	5
SW	[mm]	5	8	8	8

Part-no.

	3548-159	3548-165	3548-304	3548-163
Clamping arm short				
Weight, approx. [kg]	0.05	0.23	0.5	0.88
Cranked clamping arm				
Weight, approx. [kg]	0.11	0.3	0.84	1.3
Clamping arm assembly complete				
Weight, approx. [kg]	0.66	1.7	3.35	4.8
Carrier for clamping arm assembly				
Weight, approx. [kg]	0.08	0.18	0.5	0.7
Double clamping arm				
Weight, approx. [kg]	0.9	2	3	5.3
Carrier for double clamping arm*				
Weight, approx. [kg]	0.21	0.46	0.67	1.4
Flanged nut				
Max. tightening torque [Nm]	250	500	1100	1400
Weight, approx. [kg]	0.15	0.25	0.4	0.6

*) complete with threaded bolt and spring elements

**) Height stop surface for spring elements

Wiper system

The standard FKM wiper has a high chemical resistance against most cooling and cutting fluids.

The optional metallic wiper protects the FKM wiper against mechanical damage due to big or hot swarf.

It consists of a radially floating wiping disk and a retaining disk.

The metallic wiper can be delivered already mounted ("M") or as an accessory for retrofitting (see page 3).

Attention!

The metallic wiper is not suitable for dry machining or minimum quantity lubrication. Also in applications with very little grinding swarf, the standard FKM wiper has a better protection effect.

If there is any danger that small particles stick to the piston rod, the metallic wiper disk can also be replaced by a hard plastic disk.