

Cylindrical washer elements



Material:
 Clamping jaw: steel;
 pressure spring 1.4310;
 clamping screw: quality class 8.8

Surface finish:
 Clamping jaw black oxide finish;
 clamping screw blue galvanised

Sample order:
 nlm 03350-04

Note:
 The cylindrical washer elements are the simple alternative to conventional clamping (slot and tensioning crew of cylindrical parts).
 These components are ideally suited for the most varied materials (e.g., metals, plastics, wood...).
 To loosen a tight clamping jaw, it simply has to be hit axially or extracted by means of an additional thread in the clamping jaw respectively in the hexagon socket of the socket head screw.
 Spacer rings are available on request.

installation note:

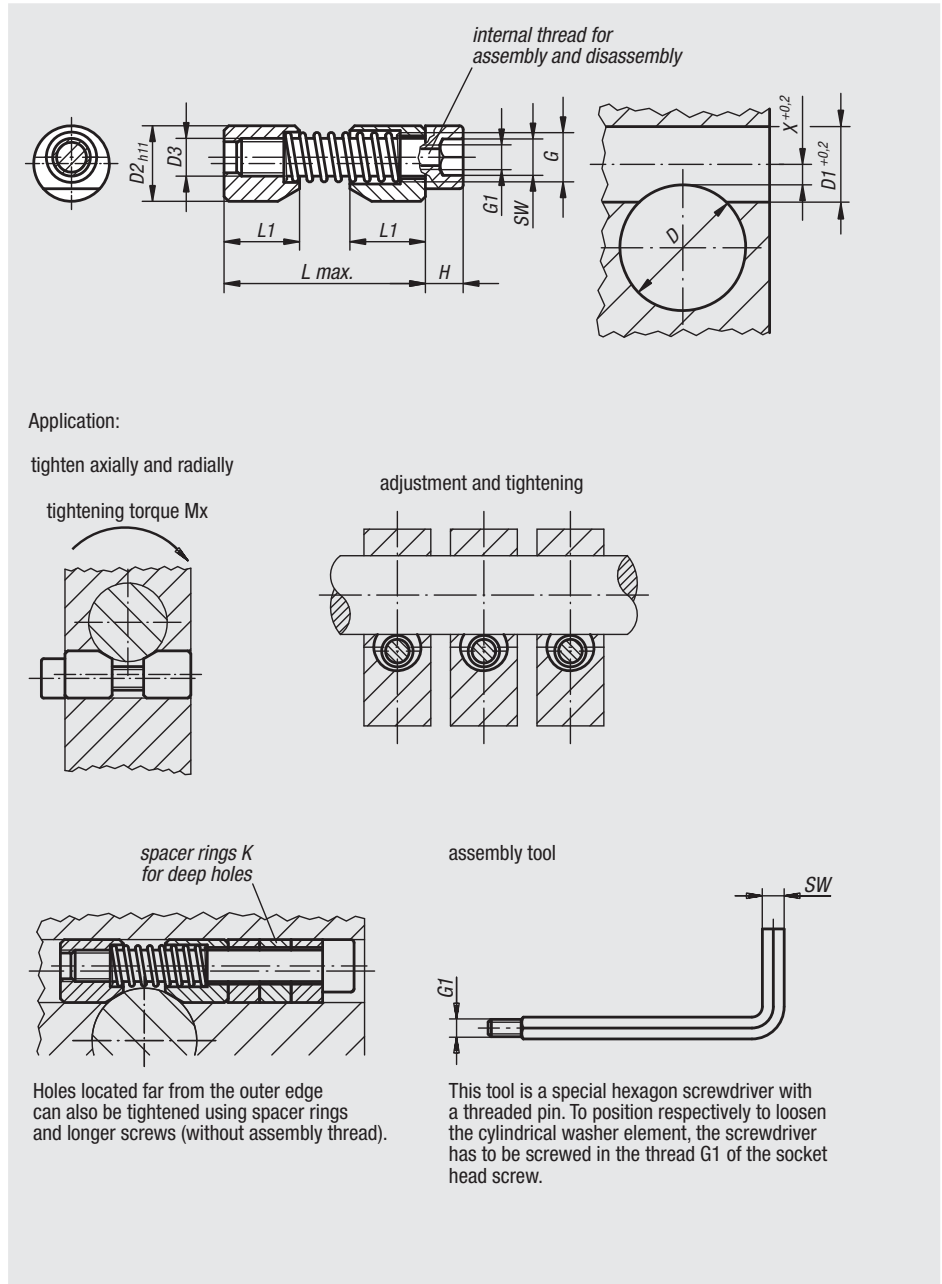
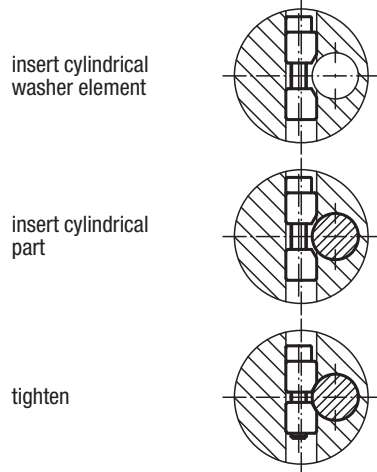

Order No.	D	D1	D2	D3	L max.	L1	X	G	G1	H	K	SW	Mx Nm	Approx. weight g	Order No. assembly tool
03350-04	6-10	8	8	M4	27	8	2,8	M5	M2,5	4	10	3	max. 20	6	03350-904
03350-05	10-15	10	10	M5	33	10	3,3	M6	M3	5	10	4	max. 45	12	03350-905
03350-06	15-20	12	12	M6	39	12	3,5	M7	M4	6	10	5	max. 100	21	03350-906
03350-08	20-30	16	16	M8	46	16	4	M10	M5	8	10	6	max. 170	52	03350-908
03350-10	30-40	20	20	M10	53	20	4,8	M12	M6	10	15	8	max. 290	98	03350-910
03350-12	40-60	25	25	M12	70	25	5,6	M14	M8	12	15	10	max. 450	183	03350-912
03350-16	60-125	30	30	M16	81	30	7,9	M18	M10	16	15	14	max. 650	344	03350-916

01000 02000 03000 04000 05000 06000 07000 08000 09000 20000 21000 22000 23000