

DOUBLE ACTING METRIC RANGE

Hydraulic equipment for all uses

◀ CONTENTS ▶

Page		Ram Style No.	
		Female Rod	Male Rod
2	General specifications		
3	Part Numbering System		
4	Basic Dimensions		
5	Load Calculations		
6	Load Calculations		
7	Buckling Calculations		
8	Buckling Calculations		
9	Pin Mounted Rams	DAM0	DAM1
10	Pin Mounted Rams with Damping	DAM10	DAM11
11	Bushed Pin Mounted Rams	DAM16	DAM17
12	Spherical Eye Mounted Rams	DAM32	DAM33
13	Spherical Eye Mounted Rams with Damping	DAM42	DAM43
14	Front Flange Mounted Rams	DAM48	DAM49
15	Rear Flange Mounted Rams	DAM64	DAM65
16	Foot Mounted Rams	DAM80	DAM81
17	Trunnion Mounted Rams	DAM96	DAM97
18	Trunnion Mounting Blocks		
19	Rod Eyes, Plain and Bushed		
20	Clevis Eyes, Plain and Bushed		
21	Spherical Eyes		
22	Spares, Installation and Maintenance		

DOUBLE ACTING METRIC RANGE

Hydraulic equipment for all uses

◀ GENERAL SPECIFICATIONS ▶

Our Double Acting Metric range of hydraulic rams are designed for heavy duty industrial service. By utilising welded construction and our many years of experience, combined with a policy of 100% product testing, we are able to provide a comparatively low cost product, on short lead times, with no compromise on quality.

The following booklet is a guide to our standard range of double acting rams. However, we also have extensive experience with many other types of hydraulic actuator. If you require a product not listed, or to a modified specification, please contact our sales office, who will be happy to advise. Options available on request include: Stainless steel piston rods, marine specification, integral hose rupture valves, low friction and chemically resistant seals, limit switches, position transducers and two pack epoxy paint finish.

Maximum pressure rating See note 1	275 Bar (4000psi) 250 Bar recommended working
Test pressure	380 Bar (5500psi) Tested in accordance with ISO10100
Maximum rod velocity	0.5 m/s
Fluid temperature range	-10 to +90 degrees C
Ambient temperature range	-10 to +90 degrees C
Filtration requirement	25 micron abs, (recommended min.)
Fluid specification	Mineral Oil DIN51524+51525 HL, H-LP & HV ISO HM (see note 2)
Fluid viscosity	5 to 200 cSt
Rod finish	20 micron hard chromium plate min Ra.=0.4

NOTE 1 ▶

Maximum pressure rating should not be exceeded, allowance must be made for pulsation and pressure peaks. Care is required to ensure pressure in the ram annulus is maintained within limits in meter out and damping applications.

NOTE 2 ▶

For use with other fluids please contact our sales office. This will ensure that testing is carried out with the correct grade of fluid and that all materials used are compatible.

The information contained in this publication is for guidance only. We reserve the right to make changes without notice. The responsibility for checking calculations, formulae, graphs and tables lies with the customer. Certified drawings are available on request. The vendor will accept no responsibility for any loss or accident howsoever caused.

DOUBLE ACTING METRIC RANGE

Hydraulic equipment for all uses

◀ PART NUMBERING SYSTEM ▶

How our part numbering system works:

example: **100-70 - DAM0 - 0250**

BORE & ROD DIAMETER in mm

25 - 16	25mm bore, 16mm rod
32 - 20	32mm bore, 20mm rod
40 - 28	40mm bore, 28mm rod
50 - 28	50mm bore, 28mm rod
50 - 40	50mm bore, 40mm rod
63 - 40	63mm bore, 40mm rod
80 - 50	80mm bore, 50mm rod
100- 70	100mm bore, 70mm rod
125- 70	125mm bore, 70mm rod
125- 90	125mm bore, 90mm rod
160- 100	160mm bore, 100mm rod
200- 140	200mm bore, 140mm rod

STROKE in mm
Refer to data sheets and buckling calculations for maximum values.

Double Acting Metric ram style

Type of Mounting	FEMALE ROD THREAD		MALE ROD THREAD	
	No Damping	Damping both ends	No Damping	Damping both ends
Pin Mounted	DAM0	DAM10	DAM1	DAM11
Bushed Pin Hole	DAM16		DAM17	
Spherical Eye	DAM32	DAM42	DAM33	DAM43
Front Flange	DAM48		DAM49	
Rear Flange	DAM64		DAM65	
Foot	DAM80		DAM81	
Trunnion	DAM96		DAM97	

DOUBLE ACTING METRIC RANGE

Hydraulic equipment for all uses

◀ BASIC DIMENSIONS ▶

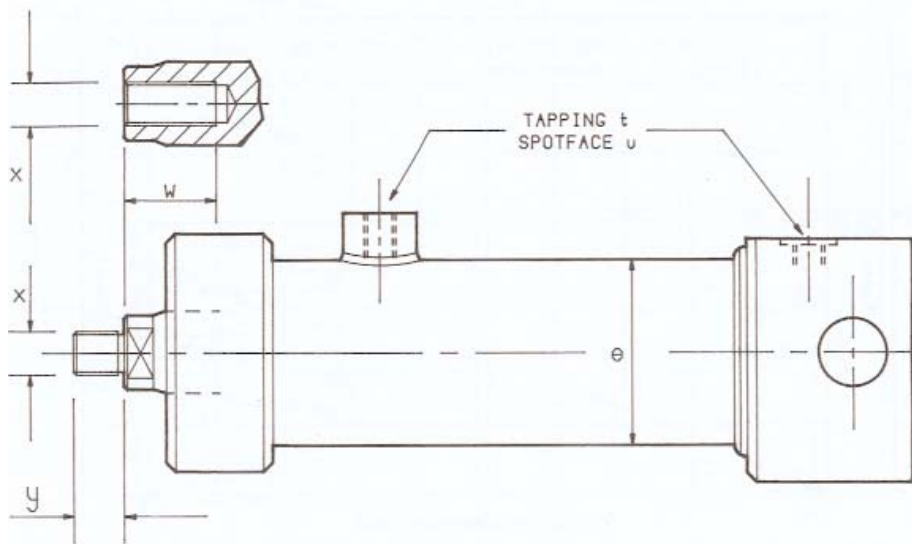

Type No.	Bore Ø	Rod Ø	Thrust Area cm ²	Pull Area cm ²	e Ø	t BSP	u Ø	w	x	y
25-16-DAM_	25	16	4.90	2.90	38	1/4"	22	25	M10x1.5	25
32-20-DAM_	32	20	8.04	4.90	40	1/4"	22	25	M12x1.75	30
40-28-DAM_	40	28	12.56	6.41	50	3/8"	25	30	M16x2.0	42
50-28-DAM_	50	28	19.63	13.47	60	3/8"	25	40	M20x1.5	48
50-40-DAM_	50	40	19.63	7.07	60	3/8"	25	40	M20x1.5	48
63-40-DAM_	63	40	31.17	18.61	73	3/8"	25	45	M24x2.0	58
80-50-DAM_	80	50	50.26	30.63	95	3/8"	25	55	M30x2.0	68
100-70-DAM_	100	70	78.54	40.06	115	1/2"	30	75	M39x3.0	80
125-70-DAM_	125	70	122.70	84.22	145	1/2"	30	90	M45x3.0	86
125-90-DAM_	125	90	122.70	59.10	145	1/2"	30	90	M45x3.0	86
160-100-DAM_	160	100	201.06	122.52	190	3/4"	38	100	M52x3.0	90
200-140-DAM_	200	140	314.16	160.22	230	1"	45	120	M64x4.0	110

All Dimensions in mm unless otherwise stated. For Mounting Dimensions please refer to relevant page

DOUBLE ACTING METRIC RANGE

Hydraulic equipment for all uses

◀ LOAD CALCULATIONS ▶

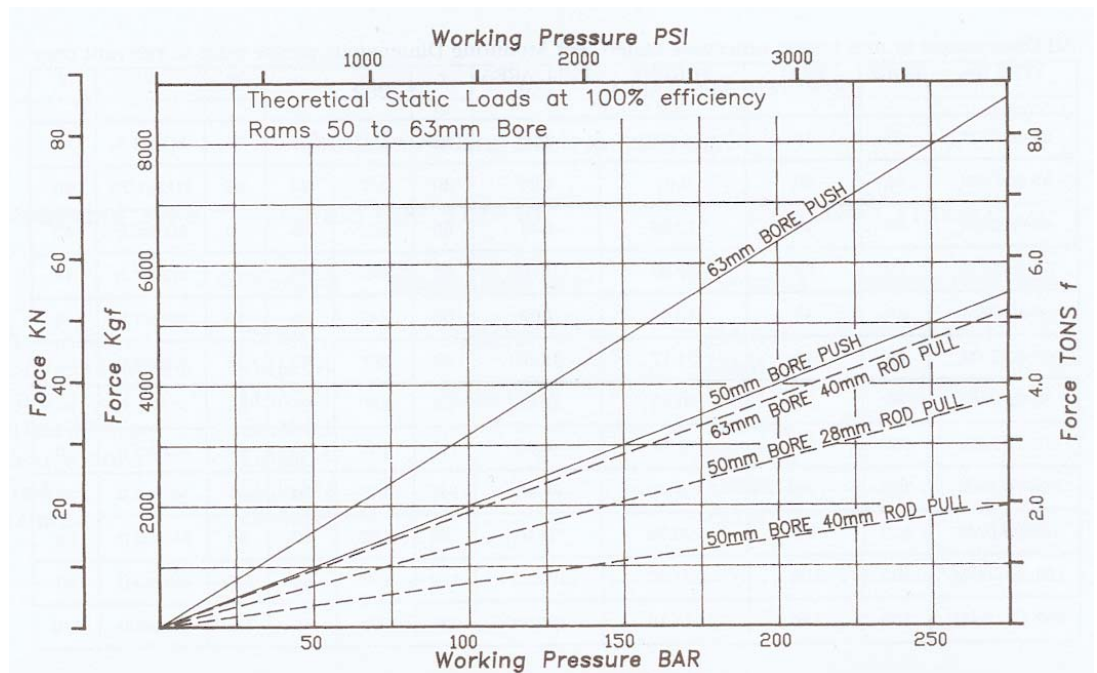
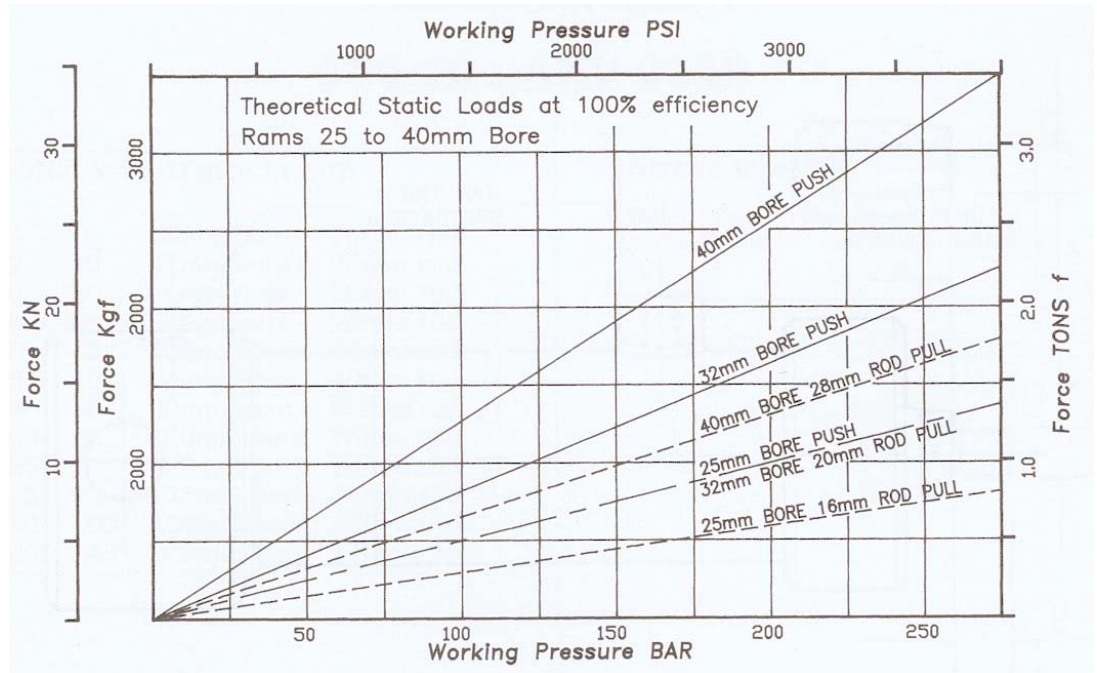

DOUBLE ACTING METRIC RANGE

Hydraulic equipment for all uses

◀ LOAD CALCULATIONS ▶

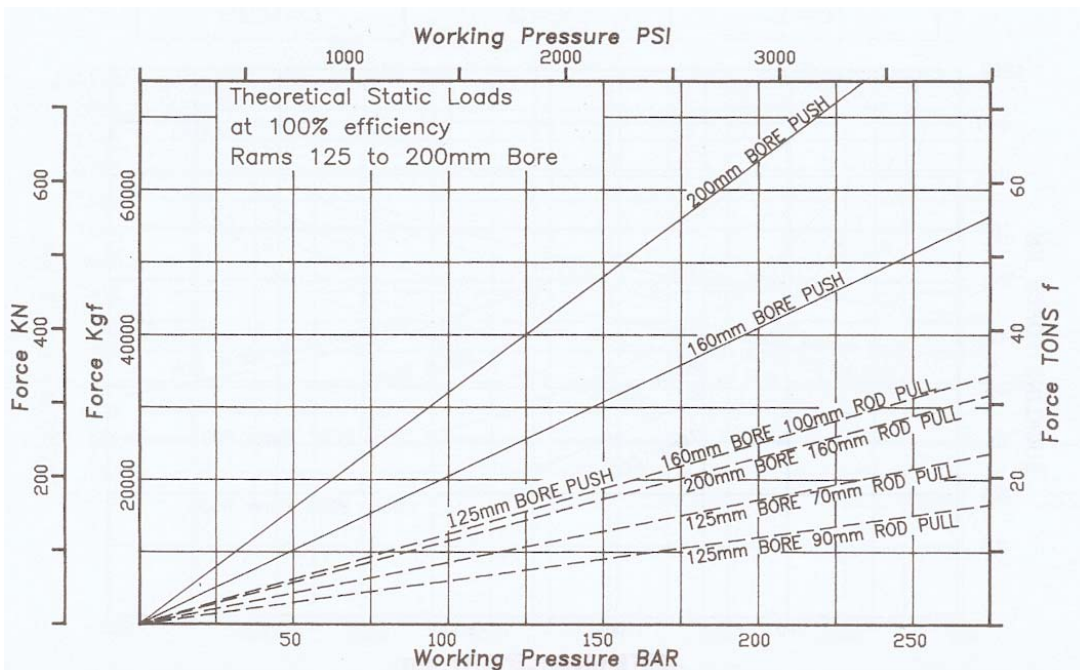
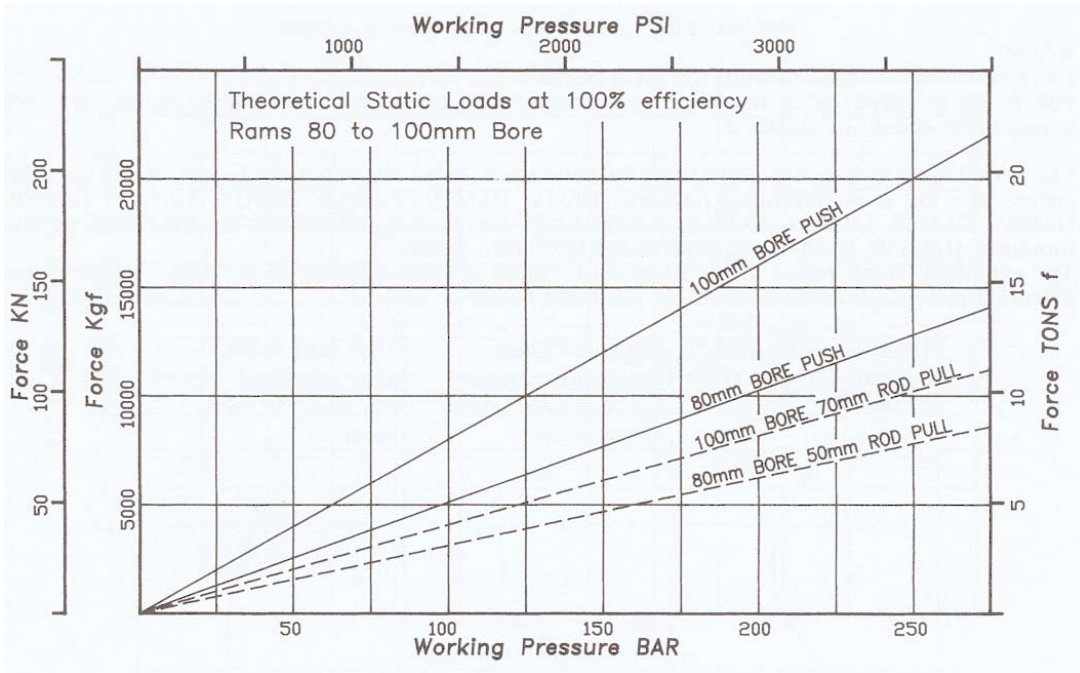

DOUBLE ACTING METRIC RANGE

Hydraulic equipment for all uses

BUCKLING CALCULATIONS

The safe working load may be determined from the formula:

$$\text{Safe Working Load} = \text{Buckling Force} \times c / \text{FoS}$$

Where:

c is a constant determined from the table below.

FoS is the required factor of safety, we recommend a minimum of 3. Where shock loads are present this should be doubled.

The actual force to cause buckling may be determined from the following graphs. Note: the solid curves are for rear mountings (DAM0, DAM1, DAM10, DAM11, DAM16, DAM17, DAM32, DAM33, DAM42, DAM43, DAM64, DAM65) and the dashed curves are for front end or foot mounting (DAM48, DAM49, DAM80, DAM81, DAM96, DAM97). The extended length refers to the distance between mounting points of the ram, effectively the extended rod length for front and foot mounted rams.

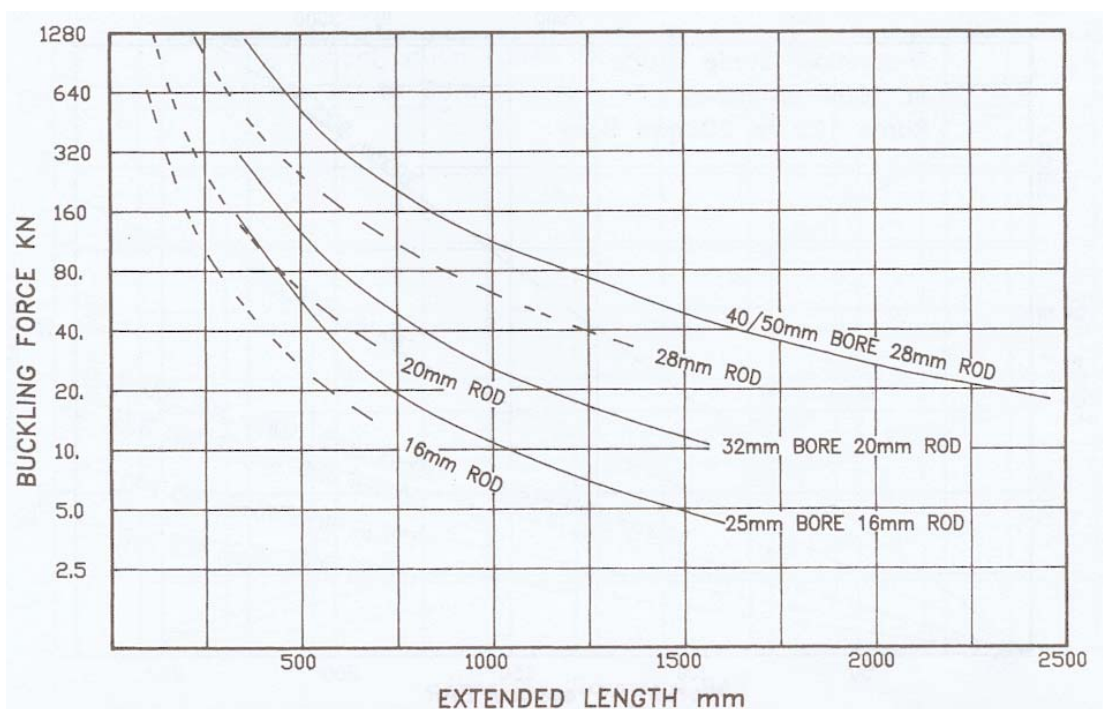
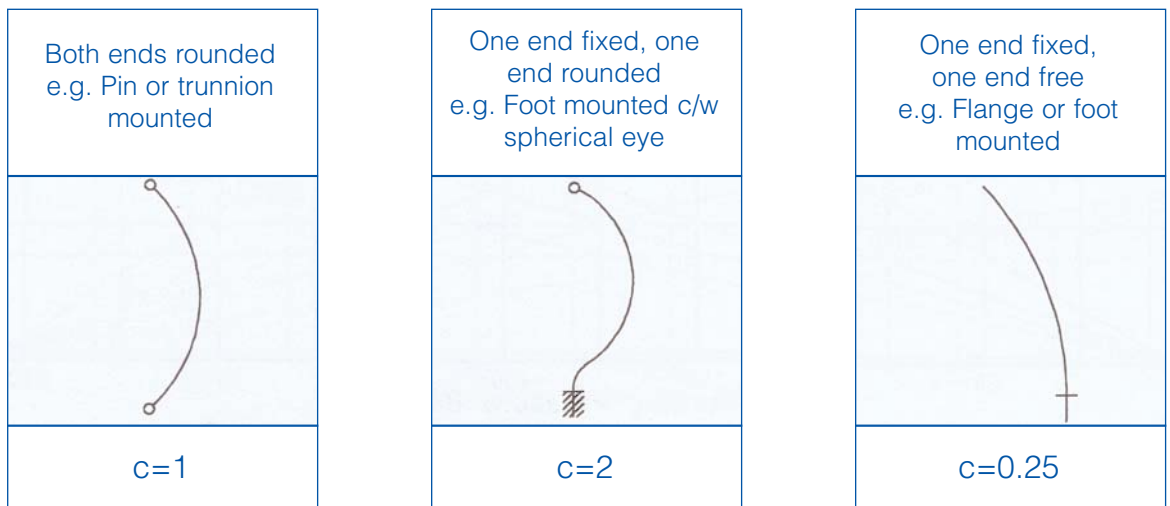

DOUBLE ACTING METRIC RANGE

Hydraulic equipment for all uses

◀BUCKLING CALCULATIONS▶

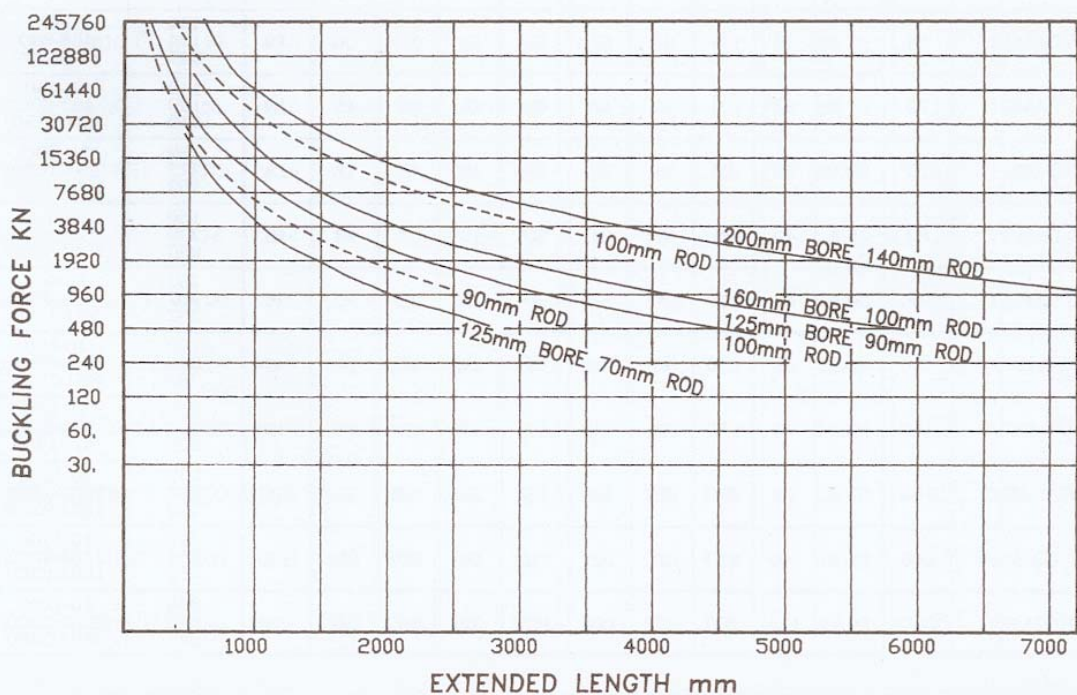
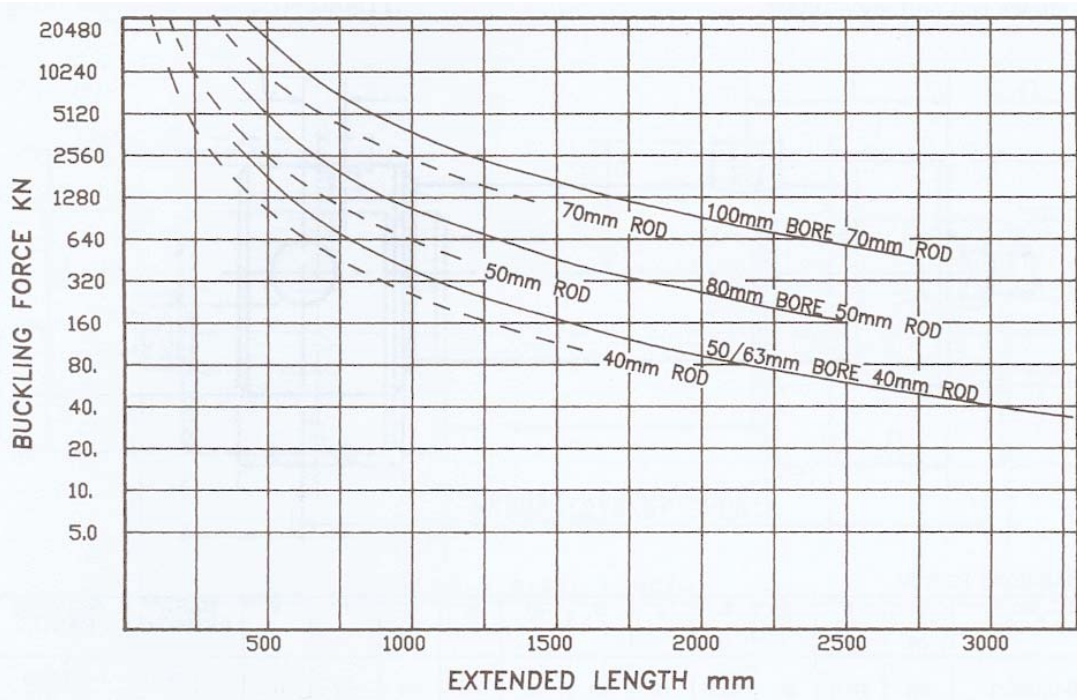

DOUBLE ACTING METRIC RANGE

Hydraulic equipment for all uses

◀ PIN MOUNTED RAMS ▶

Note: If rams are required for angular movements, bushes or spherical end bearings should be considered. Diagram shows rod end style DAM1.

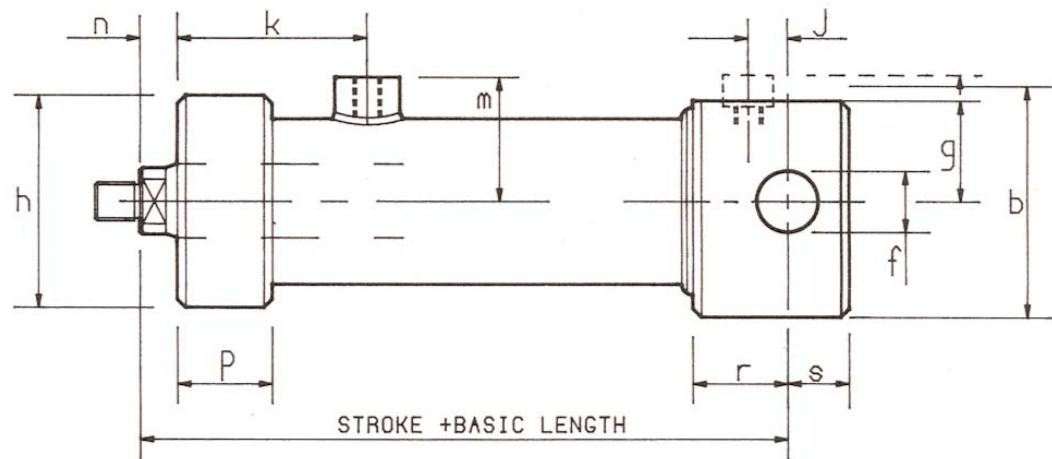

Type No.	b Ø	f Ø	g	h Ø	j	k	m	n	p	r	s	basic length	stroke range
25-16-DAM 0/1	38	10.5	29	44.5	13	49	29	10	26	27	10	123 173	10-350 351-700
32-20-DAM 0/1	45	12.5	20	45	13	51	30	12	31	26	11	132 152	10-457 458-725
40-28-DAM 0/1	55	17.5	25	55	15	57	37	14	36	30	14	144 194 244	10-457 458-850 851-1350
50-28-DAM 0/1	70	20.5	32	70	0	48	43	15	28	15	18	140 190 240	10-450 451-800 801-1150
50-40-DAM 0/1	70	20.5	32	70	0	70	43	15	47	15	18	162 212 262	10-500 501-1000 1001-1500
63-40-DAM 0/1	80	25.4	40	85	0	61	50	16	30	14	18	150 200 250	10-610 611-1000 1001-1500
80-50-DAM 0/1	100	30.5	48	100	4	57	60	18	32	22	25	157 207 257	10-400 401-750 751-1100
100-70-DAM 0/1	130	40.5	62	130	11	72	71	22	42	30	35	199 249 299	10-500 501-850 851-1200
125-70-DAM 0/1	150	50.5	72	150	15	80	87	24	50	35	43	224 274 324	10-500 501-900 901-1250
125-90-DAM 0/1	150	50.5	72	150	15	84	87	24	50	35	43	233 283 333	10-1000 1001-1620 1621-2200
160-100-DAM 0/1	200	60.5	100	210	16	108	115	26	70	40	50	279 359 439	10-1100 1101-1900 1901-2700
200-140-DAM 0/1	250	80.5	125	250	25	126	135	32	75	56	65	344 444 544	10-1900 1901-2300 2301-3300

DOUBLE ACTING METRIC RANGE

Hydraulic equipment for all uses

◀ PIN MOUNTED RAMS with DAMPING ▶

Note: Damping must be adjusted to ensure excessive impulse pressures are not induced. Diagram shows rod end style DAM11.

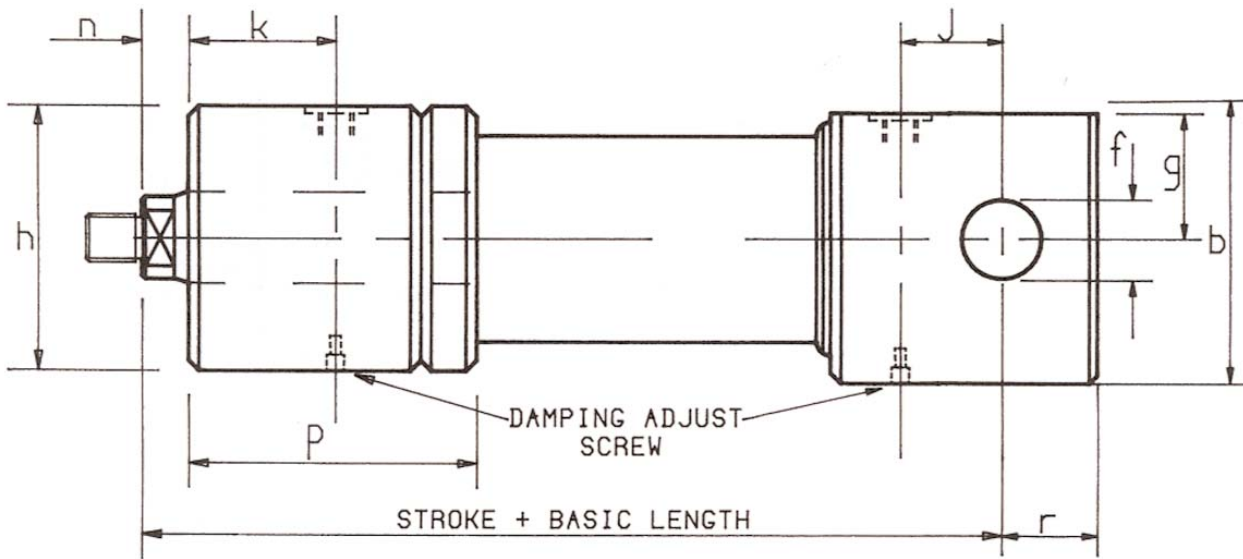

Type No.	b Ø	f Ø	g	h Ø	j	k	n	p	r	damping length	basic length	stroke range
32-20-DAM 10/11	45	12.5	20	62	16	44	12	90	11	15	183	40-725
40-28-DAM 10/1	55	17.5	25	70	20	42	14	90	14	25	177 227	60-850 851-1350
50-28-DAM 10/11	70	20.5	32	80	23	48	15	98	18	25	190 240 290	60-450 451-800 801-1150
63-40-DAM 10/11	76	25.4	38	94	28	65	16	120	18	25	219 269 319	60-610 611-1000 1001-1500
80-50-DAM 10/11	100	30.5	48	112	30	73	18	133	25	25	267 317	60-750 751-1100
100-70-DAM 10/11	115	40.5	58	135	40	86	22	146	35	25	308 358	60-850 851-1200
125-70-DAM 10/11	150	50.5	75	160	45	88	24	158	43	25	308 358	60-900 901-1250
125-90-DAM 10/11	150	50.5	75	160	45	88	24	158	43	25	308 358	60-1100 1101-2200
160-100-DAM 10/11	200	60.5	100	210	55	117	26	210	50	38	394 494	60-1350 1351-2700
200-140-DAM 10/11	250	80.5	125	250	66	145	32	240	65	38	567 667	90-1700 1701-3300

DOUBLE ACTING METRIC RANGE

Hydraulic equipment for all uses

◀ BUSHED PIN MOUNTED RAMS ▶

Note: Diagram shows rod end style DAM17.

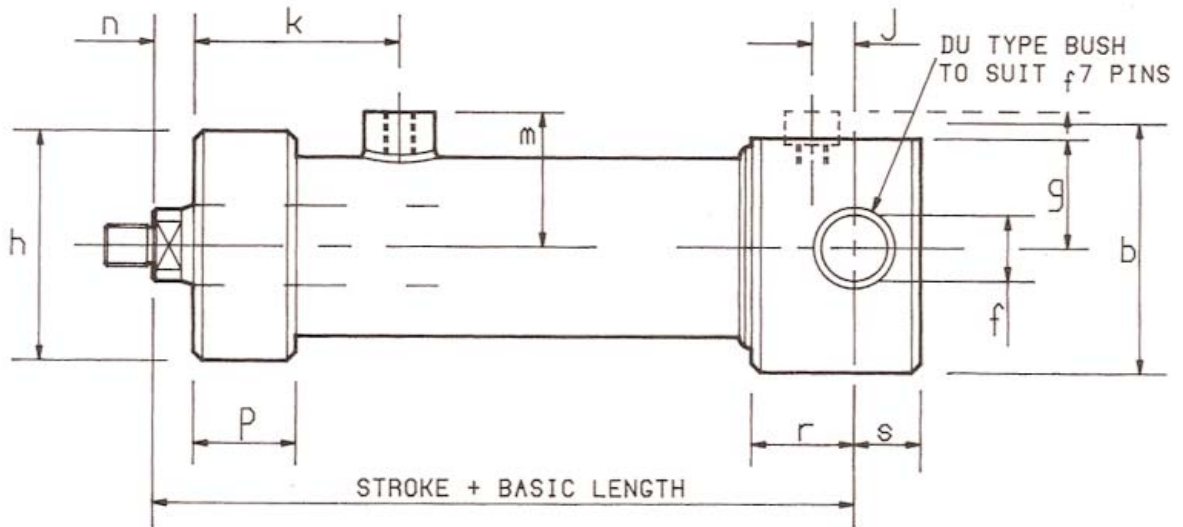

Type No.	b Ø	f h8 Ø	g	h Ø	j	k	m	n	p	r	s	basic length	stroke range
25-16-DAM 16/17	38	10	29	45	13	49	29	10	26	27	10	123 173	10-350 351-700
32-20-DAM 16/17	45	12	20	45	13	51	30	12	31	26	11	132 152 172	10-457 458-725 726-1100
40-28-DAM 16/17	55	17	25	55	15	57	37	14	36	30	14	144 194 244	10-457 458-850 851-1350
50-28-DAM 16/17	70	20	32	70	0	48	43	15	28	15	18	140 190 240	10-450 451-800 801-1150
50-40-DAM 16/17	70	20	32	70	0	70	43	15	47	15	18	162 212 262	10-500 501-1000 1001-1500
63-40-DAM 16/17	80	25	40	85	0	61	50	16	30	14	18	150 200 250	10-610 611-1000 1001-1500
80-50-DAM 16/17	100	30	48	100	4	57	60	18	32	22	25	157 207 257	10-400 401-750 751-1100
100-70-DAM 16/17	130	40	62	130	11	72	71	22	42	30	35	199 249 299	10-500 501-850 851-1200
125-70-DAM 16/17	150	50	72	150	15	80	87	24	50	35	43	224 274 324	10-500 501-900 901-1250
125-90-DAM 16/17	150	50	72	150	15	84	87	24	50	35	43	233 283 333	10-1000 1001-1620 1621-2200
160-100-DAM 16/17	200	60	100	210	16	108	115	26	70	40	50	279 359 439	10-1100 1101-1900 1901-2700
200-140-DAM 16/17	250	80	125	250	25	126	135	32	75	56	65	344 444 544	10-1900 1901-2300 2301-3300

DOUBLE ACTING METRIC RANGE

Hydraulic equipment for all uses

◀ SPHERICAL EYE MOUNTED RAMS ▶

Note: Diagram shows rod end style DAM33.

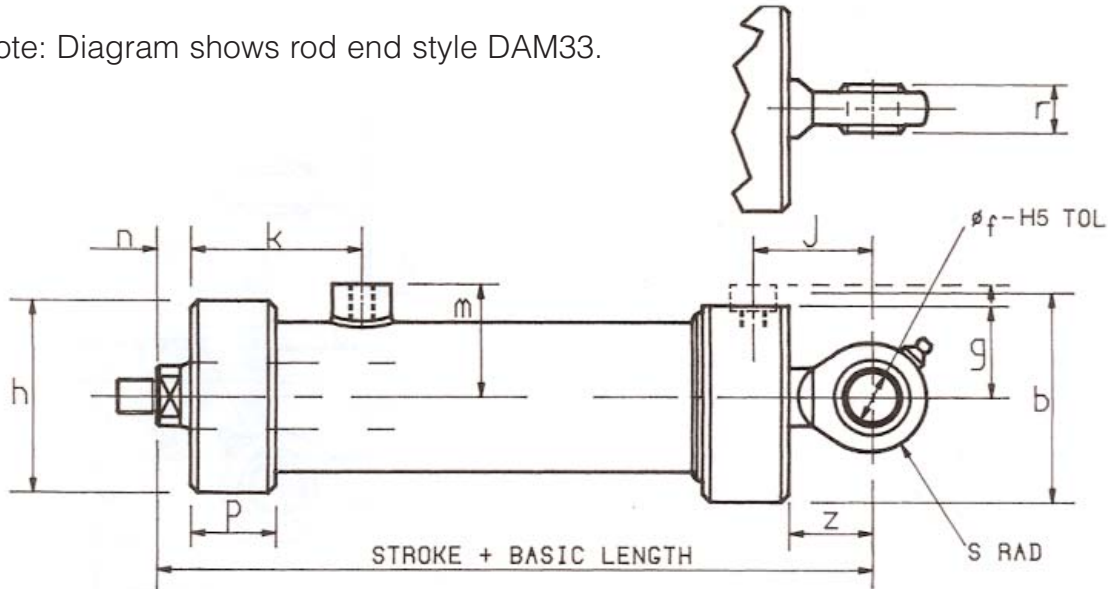

Type No.	b Ø	f Ø	g	h Ø	j	k	m	n	p	r	s	z	basic length	stroke range
25-16-DAM 32/33	38	10	29	45	39	52	26	10	32	9	15	24	149 199	10-350 351-700
32-20-DAM 32/33	45	12	20	45	40	51	30	12	31	10	17	27	158 178	10-457 458-725
40-28-DAM 32/33	55	17	25	55	53	57	37	14	36	14	22.5	35	182 232 282	10-457 458-850 851-1350
50-28-DAM 32/33	70	20	32	70	55	48	43	15	28	16	25.5	38	193 243 293	10-450 451-800 801-1150
50-40-DAM 32/33	70	20	32	70	55	70	43	15	47	16	25.5	38	215 265 315	10-500 501-1000 1001-1500
63-40-DAM 32/33	80	25	40	85	63	61	50	16	30	20	30	45	213 263 313	10-610 611-1000 1001-1500
80-50-DAM 32/33	100	30	48	100	72	57	60	18	32	22	35	51	223 273 323	10-400 401-750 751-1100
100-70-DAM 32/33	130	40	62	130	94	72	71	22	42	28	48	69	281 331 381	10-500 501-850 851-1200
125-70-DAM 32/33	150	50	72	150	106	80	87	24	50	35	61	88	312 331 412	10-500 501-900 901-1250
125-90-DAM 32/33	150	50	72	150	106	84	87	24	50	35	61	88	321 371 421	10-1000 1001-1620 1621-2200
160-100-DAM 32/33	200	60	100	210	126	108	115	26	70	44	71	100	384 464 544	10-1100 1101-1900 1901-2700
200-140-DAM 32/33	250	80	125	250	171	126	135	32	75	55	94	141	485 585 685	10-1300 1301-2300 2301-3300

DOUBLE ACTING METRIC RANGE

Hydraulic equipment for all uses

◀ SPHERICAL EYE MOUNTED RAMS ▶ with DAMPING

Note: Damping must be adjusted to ensure excessive impulse pressures are not induced. Diagram shows rod end style DAM43.

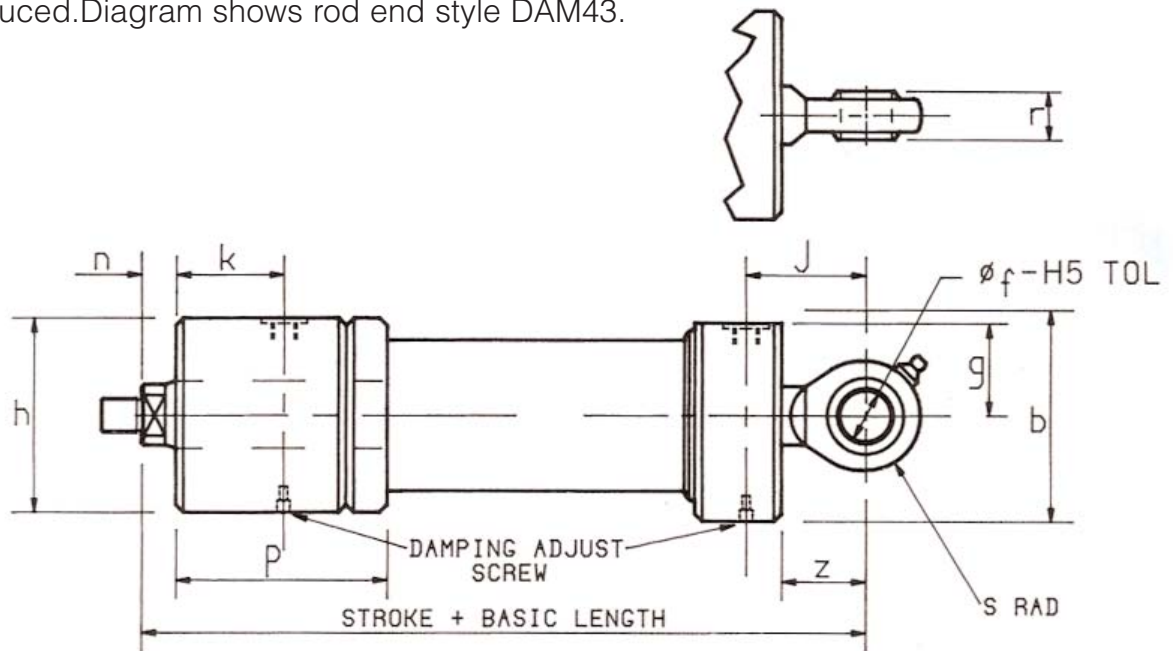

Type No.	b Ø	f Ø	g	h Ø	j	k	n	p	r	s	z	damped length	basic length	stroke range
32-20-DAM 42/43	45	12	20	62	43	44	12	90	10	17	27	15	210	40-725
40-28-DAM 42/43	55	17	25	70	53	42	14	90	14	22.5	35	25	211 261	60-850 851-1350
50-28-DAM 42/43	70	20	32	80	58	48	15	98	16	25.5	38	25	225 275 325	60-450 451-800 801-1150
63-40-DAM 42/43	76	25	38	94	65	65	16	120	20	30	45	25	258 308 358	60-610 611-1000 1001-1500
80-50-DAM 42/43	100	30	48	112	71	73	18	133	22	35	51	25	305 355	60-750 751-1100
100-70-DAM 42/43	115	40	58	135	89	86	22	146	28	48	69	25	352 402	60-850 851-1200
125-70-DAM 42/43	150	50	75	160	110	88	24	158	35	61	88	25	370 420	60-900 901-1250
125-90-DAM 42/43	150	50	75	160	110	88	24	158	35	61	88	25	370 420	60-1100 1101-2200
160-100-DAM 42/43	190	60	92	210	126	117	26	208	44	68	100	38	466 546	60-1350 1351-2700
200-140-DAM 42/43	225	80	110	250	171	145	32	238	55	94	141	38	567 667	90-1700 1701-3300

DOUBLE ACTING METRIC RANGE

Hydraulic equipment for all uses

◀ FRONT FLANGE MOUNTED RAMS ▶

Note: Diagram shows rod end style DAM49.

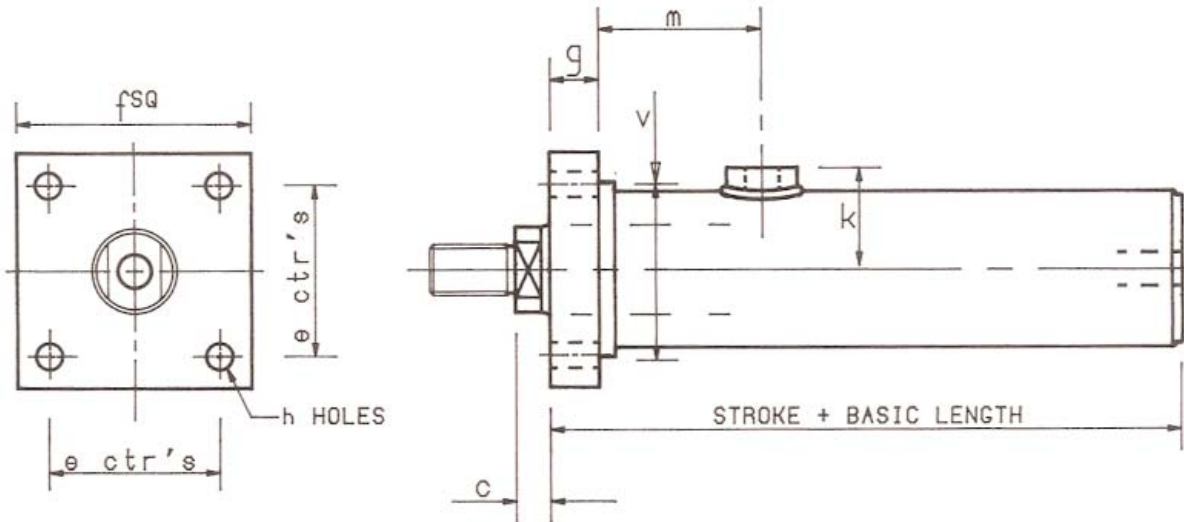

Type No.	c	e	f	g	h Ø	k	m	v Ø	basic length	stroke range
25-16-DAM 48/49	10	45	60	10	6.35	26	40	47	108	10-711
32-20-DAM 48/49	12	50	70	18	9	30	39	50	113 133	10-457 458-725
40-28-DAM 48/49	14	60	80	20	8.5	37	39	60	116 166 216	10-457 458-850 851-1350
50-28-DAM 48/49	15	65	90	23	10.5	41	33	70	130 180 230	10-450 451-800 801-1150
50-40-DAM 48/49	15	65	90	23	10.5	43	47	70	153 203 253	10-500 501-1000 1001-1500
63-40-DAM 48/49	16	80	114	23	12.5	50	46	82	139 189 239	10-610 611-1000 1001-1500
80-50-DAM 48/49	18	100	130	23	16.5	59	40	110	137 187 237	10-400 401-750 751-1100
100-70-DAM 48/49	22	120	160	28	21	72	54	130	174 224 274	10-500 501-850 851-1200
125-70-DAM 48/49	24	150	200	35	25	87	58	160	197 247 297	10-500 501-900 901-1250
125-90-DAM 48/49	24	150	200	35	25	87	58	160	203 253 303	10-1000 1001-1600 1601-2200
160-100-DAM 48/49	26	200	280	65	38	115	55	n/a	262 342 422	10-1100 1101-1900 1901-2700
200-140-DAM 48/49	32	250	340	65	50	135	71	245	312 412 512	10-1300 1301-2300 2301-3300

DOUBLE ACTING METRIC RANGE

Hydraulic equipment for all uses

◀ REAR FLANGE MOUNTED RAMS ▶

Note: Diagram shows rod end style DAM65.

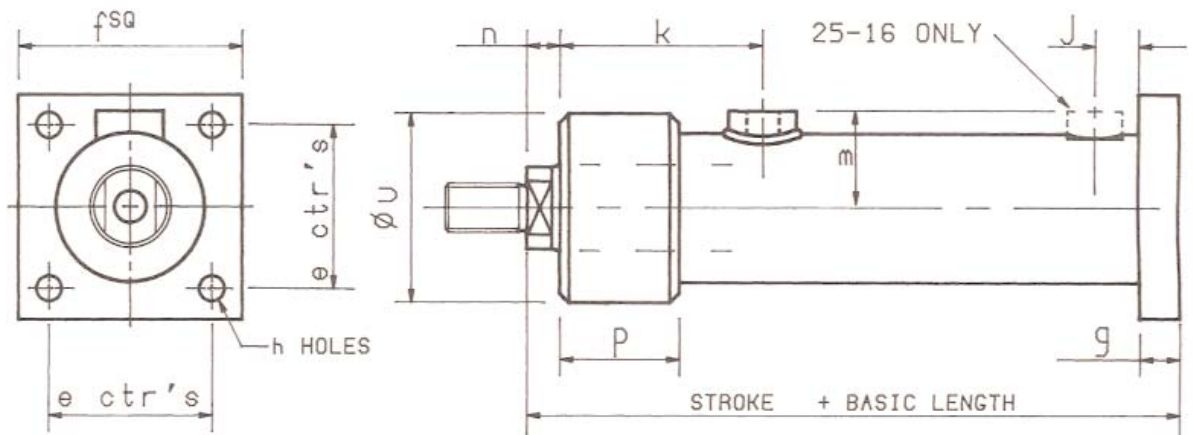

Type No.	e	f	g	h Ø	j	k	m	n	p	u Ø	basic length	stroke range
25-16-DAM 64/65	45	60	10	6.35	21	49	29	10	26	44.5	120	10-700
32-20-DAM 64/65	50	70	18	9	20	51	30	12	31	45	157 177	10-457 458-725
40-28-DAM 64/65	60	80	20	8.5	21	57	37	14	36	55	170 220 270	10-457 458-850 851-1350
50-28-DAM 64/65	65	90	23	10.5	21	48	41	15	28	70	194 244 294	10-450 451-800 801-1150
50-40-DAM 64/65	65	90	23	10.5	21	70	41	15	47	70	206 256 306	10-500 501-1000 1001-1500
63-40-DAM 64/65	80	114	23	12.5	22	61	50	16	30	85	195 245 295	10-610 611-1000 1001-1500
80-50-DAM 64/65	100	130	23	16.5	21	57	60	18	32	100	195 245 295	10-400 401-750 751-1100
100-70-DAM 64/65	120	160	28	21	25	72	71	22	42	130	240 290 340	10-500 501-850 851-1200
125-70-DAM 64/65	150	200	35	25	28	80	87	24	50	150	267 317 367	10-500 501-900 901-1250
125-90-DAM 64/65	150	200	35	25	28	84	87	24	50	150	278 328 378	10-1000 1001-1600 1601-2200
160-100-DAM 64/65	200	280	65	38	35	108	115	26	70	210	358 438 518	10-1100 1101-1900 1901-2700
200-140-DAM 64/65	200	340	65	50	40	126	135	32	75	250	419 519 619	10-1300 1301-2300 2301-3300

DOUBLE ACTING METRIC RANGE

Hydraulic equipment for all uses

◀ FOOT MOUNTED RAMS ▶

Note: Care must be taken to ensure that the mounting bolts do not fail in shear.
Diagram shows rod end style DAM81.

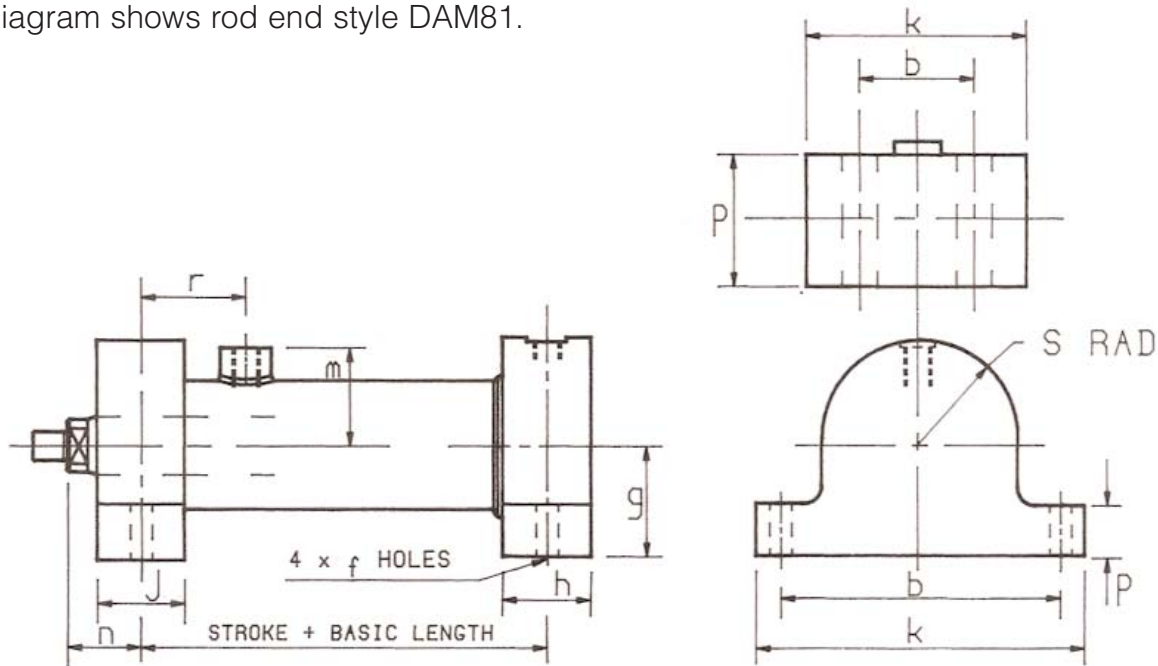

Type No.	b	f Ø	g	h	j	k	m	n	p	r	s	basic length	stroke range
25-16-DAM 80/81	50	10.5	24	24	32	70	29	26	49	37	-	75	10-700
32-20-DAM 80/81	54	10.5	25	24	36	70	30	30	50	38	-	86 106	10-457 458-725
40-28-DAM 80/81	100	10.5	32	38	38	130	37	33	16	43	32	98 148 198	10-457 458-850 851-1350
50-28-DAM 80/81	110	12.7	38	32	32	140	43	31	18	37	38	98 148 198	10-450 451-800 801-1150
50-40-DAM 80/81	110	12.7	38	48	48	140	43	39	18	45	38	121 171 221	10-500 501-1000 1001-1500
63-40-DAM 80/81	130	17	45	38	38	170	50	35	20	49	45	118 168 218	10-610 611-1000 1001-1500
80-50-DAM 80/81	150	21	55	38	38	190	60	37	22	45	55	116 166 216	10-400 401-750 751-1100
100-70-DAM 80/81	190	25	70	48	48	240	71	46	25	52	70	137 187 237	10-500 501-850 851-1200
125-70-DAM 80/81	240	31	90	58	58	300	90	53	35	59	90	160 210 260	10-500 501-900 901-1250
125-90-DAM 80/81	240	31	90	58	58	300	90	53	35	59	90	173 223 273	10-1000 1001-1600 1601-2200

DOUBLE ACTING METRIC RANGE

Hydraulic equipment for all uses

◀ TRUNNION MOUNTED RAMS ▶

Note: Diagram shows rod end style DAM97.

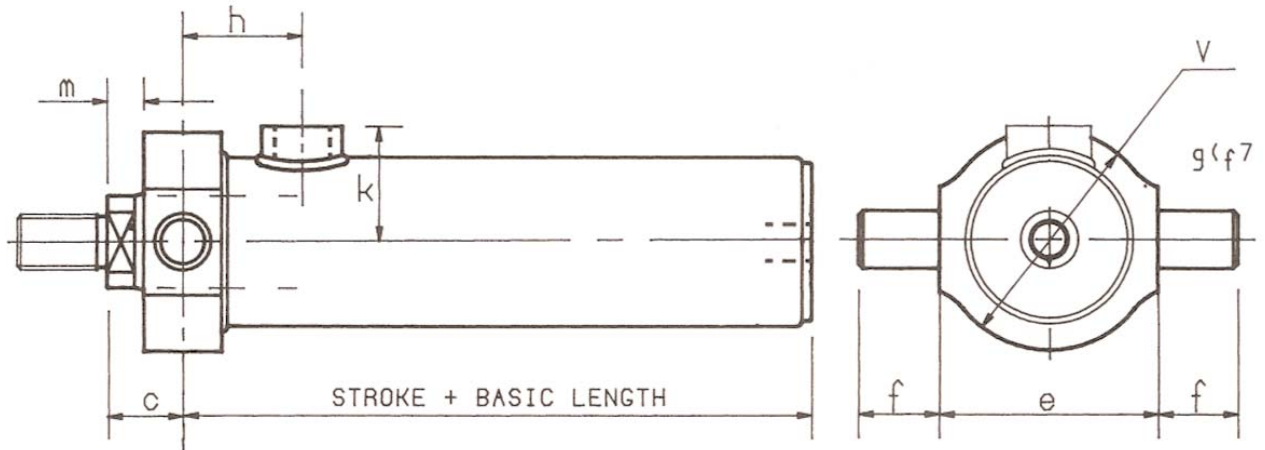

Type No.	c	e	f	$g \begin{smallmatrix} f \\ 7 \end{smallmatrix}$ Ø	h	k	m	v	basic length	stroke range
25-16-DAM 96/97	25	50	16	10	35	29	10	50	93 143	10-350 351-700
32-20-DAM 96/97	31	55	18	12	38	30	12	55	94 114	10-457 458-725
40-28-DAM 96/97	31	65	20	17	43	37	14	65	98 148 198	10-457 458-850 851-1350
50-28-DAM 96/97	32	80	25	20	39	41	15	80	113 163 213	10-450 451-800 801-1150
50-40-DAM 96/97	39	80	25	20	46	43	15	80	129 179 229	10-500 501-1000 1001-1500
63-40-DAM 96/97	33	100	35	25	52	50	16	95	122 172 222	10-610 611-1000 1001-1500
80-50-DAM 96/97	37	120	45	30	45	59	18	120	118 168 218	10-400 401-750 751-1100
100-70-DAM 96/97	48	140	50	40	59	72	22	140	148 198 248	10-500 501-850 851-1200
125-70-DAM 96/97	57	180	60	50	67	87	24	180	164 214 264	10-500 501-900 901-1250
125-90-DAM 96/97	57	180	60	50	67	87	24	180	170 220 270	10-1000 1001-1600 1601-2200
160-100-DAM 96/97	64	240	80	60	82	115	26	240	224 304 384	10-1100 1101-1900 1901-2700
200-140-DAM 96/97	85	280	100	80	97	135	32	280	259 359 459	10-1300 1301-2300 2301-3300

DOUBLE ACTING METRIC RANGE

Hydraulic equipment for all uses

◀ TRUNNION MOUNTING BLOCKS ▶

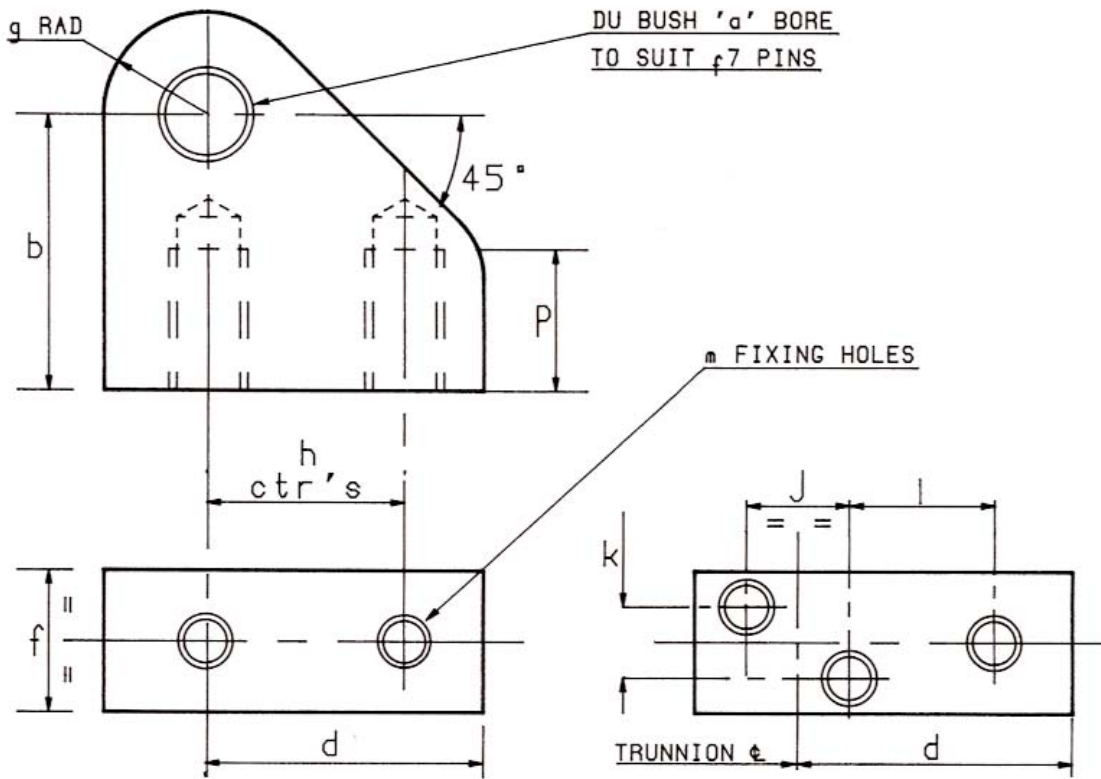

Part No. (pair)	a ϕ	b	d	f	g	h	k	j	l	m	No. of holes	P
25-16-0350	10	30	30	15	12	22	-	-	-	M8	2	15
32-20-0351	12	35	35	18	13	25	-	-	-	M10	2	18
40-28-0353	17	40	40	20	18	30	-	-	-	M12	2	18
50-28-0353	20	45	45	24	20	32	-	-	-	M16	2	22
63-40-0354	25	55	55	33	25	38	-	-	-	M20	2	25
80-50-0351	30	65	65	43	30	45	-	-	-	M24	2	30
100-70-0354	40	80	80	48	38	55	-	-	-	M30	2	35
125-70-0350	50	100	100	58	50	70	-	-	-	M36	2	50
160-100-0350	60	130	130	78	60	-	36	36	82	M30	3	50
200-140-0351	80	160	160	100	70	-	40	40	110	M36	3	60

DOUBLE ACTING METRIC RANGE

Hydraulic equipment for all uses

◀ ROD EYES, PLAIN & BUSHED ▶

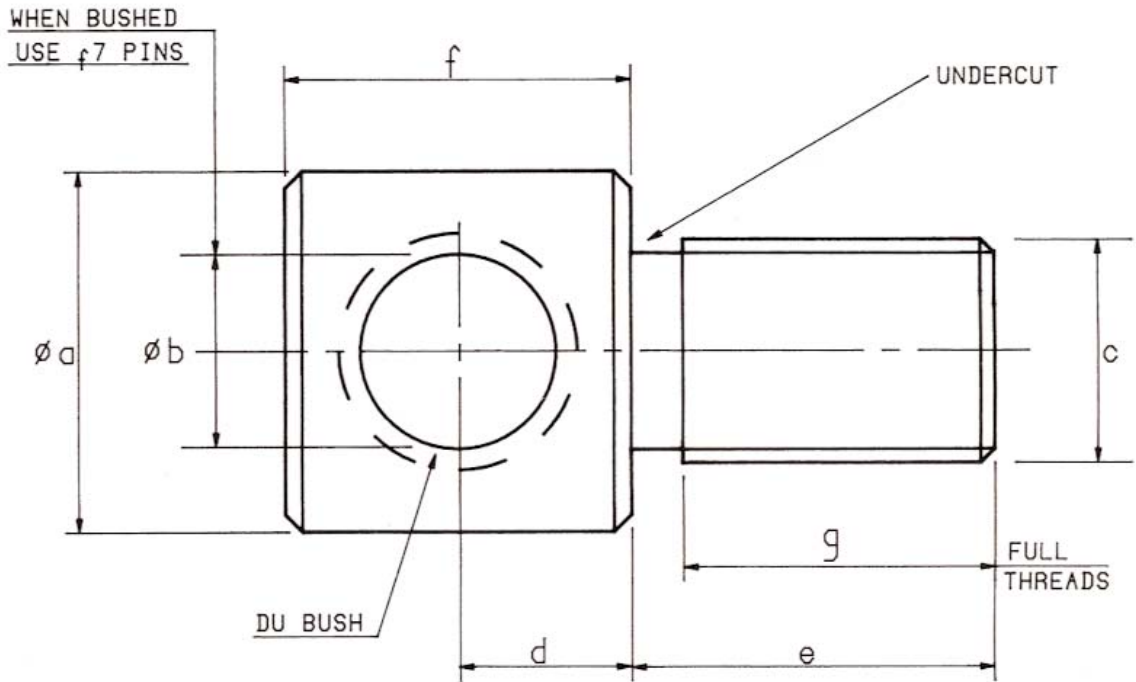

Part No. Without bush #	Part No. With bush *	To suit RAM	a Ø	b# Ø	b* Ø	c	d	e	f	g
25-16-0115	25-16-0116	25-16-DAM_	22	10.5	10	M10x1.5	10	22	20	18
32-20-0113	32-20-0115	32-20-DAM_	25	12.5	12	M12x1.75	11	23	22	19
40-28-1112	40-28-1115	40-28-DAM_	40	17.5	17	M16x2	17	28	33	23
50-28-2111	50-28-2112	50-28-DAM_	40	20.5	20	M20x1.5	17	36	33	32
50-40-0116	50-40-0117	50-40-DAM_	50	20.5	20	M20x1.5	20	36	40	32
63-40-1115	63-40-1117	63-40-DAM_	50	25.4	25	M24x2	20	36	40	31
80-50-1113	80-50-1115	80-50-DAM_	60	30.5	30	M30x2	25	40	50	35
100-70-1115	100-70-1116	100-70-DAM_	80	40.5	40	M39x3	35	50	70	42
125-70-0118	125-70-0119	125-70-DAM_	90	50.5	50	M45x3	40	50	80	42
160-100-0114	160-100-0115	160-100-DAM_	130	60.5	60	M52x3	50	70	100	62
200-140-0112	200-140-0113	200-140-DAM_	160	80.5	80	M64x4	65	90	130	80

DOUBLE ACTING METRIC RANGE

Hydraulic equipment for all uses

◀ CLEVIS EYES, PLAIN & BUSHED ▶

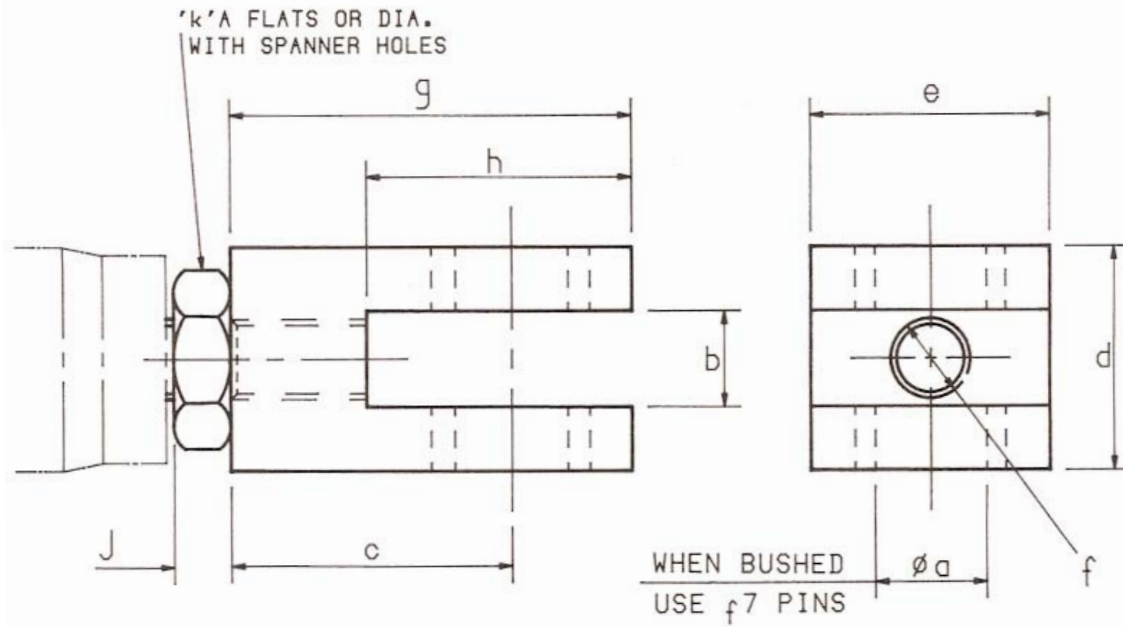

Part no. Without bush #	Part no. With bush *	Locknut part no.	a # Ø	a* Ø	b	c	d	e	f	g	h	j	k
25-16-0270	25-16-0271	25-16-0480	10.5	10	13	35	30	20	M10x1.5	45	27	6	17
32-20-0271	32-20-0272	32-20-0480	12.5	12	20	42	40	25	M12x1.75	55	32	7	19
40-28-0274	40-28-0275	40-28-0482	17.5	17	20	60	40	40	M16x2	80	45	9	24
50-28-1270	50-28-1271	50-28-0480	20.5	20	23	68	45	45	M20x1.5	90	50	9	30
63-40-1275	63-40-1276	63-40-0482	25.4	25	26	80	57	57	M24x2	108	60	10	36
80-50-1276	80-50-1277	80-50-0455	30.5	30	32	93	63.5	63.5	M30x2	125	70	12	45
100-70-1276	100-70-1277	100-70-0452	40.5	40	40	115	80	80	M39x3	155	90	16	55
125-70-0271	125-70-0272	125-70-0451	50.5	50	52	135	114	114	M45x3	190	120	18	63
160-100-0270	160-100-0271	160-100-0450	60.5	60	62	145	127	127	M52x3	210	140	20	76
200-140-0270	200-140-0271	200-140-0450	80.5	80	77	180	152	152	M64x4	260	175	26	90

DOUBLE ACTING METRIC RANGE

Hydraulic equipment for all uses

◀ SPHERICAL EYES ▶

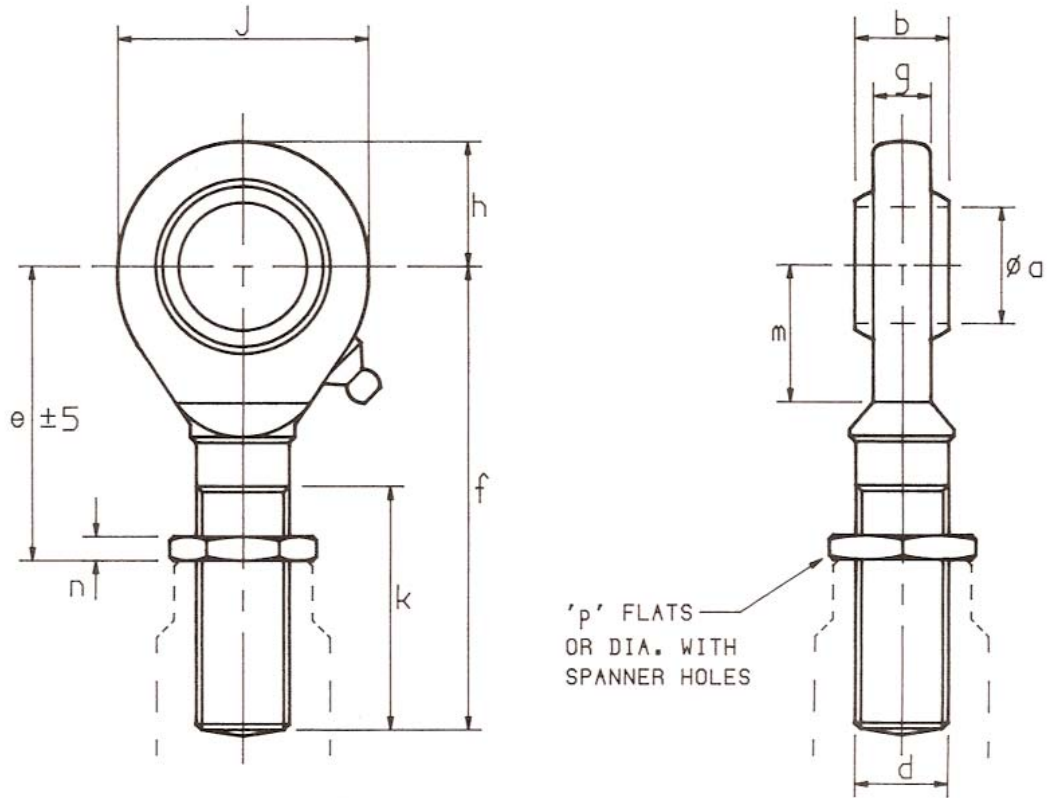

End eye part no.	Locknut part no.	a h5 Ø	b	d	e	f	g	h	j	k	m	n	p
25-16-0436	25-16-0480	10	9	M10x1.5	33	48	7	15	29	26	15	6	17A/F
32-20-0431	32-20-0480	12	10	M12x1.75	38	54	8	17	34	28	18	7	19A/F
40-28-0439	40-28-0482	17	14	M16x2	47	69	11	23	46	36	23	9	24A/F
50-28-0438	50-28-0480	20	16	M20x1.5	49	78	13	26.5	53	43	17	9	30A/F
63-40-0433	63-40-0482	25	20	M24x2	56	94	17	32	64	53	32	10	36A/F
80-50-0437	80-50-0455	30	22	M30x2	62	110	19	36.5	73	65	31	12	45DIA
100-70-0438	100-70-0452	40	28	M39x3	85	150	23	46	92	86	48	16	55DIA
125-70-0437	125-70-0451	50	35	M45x3	104	185	30	56	112	107	60	18	63.5DIA
160-100-0430	160-100-0450	60	44	M52x3	120	210	38	68	135	115	75	20	76DIA
200-140-0431	200-140-0450	80	55	M64x4	162	270	47	90	180	140	100	26	90DIA

DOUBLE ACTING METRIC RANGE

Hydraulic equipment for all uses

◀ SPARES, INSTALLATION & MAINTENANCE ▶

SPARES ▶

Please ensure that you always state the ram serial number when ordering spares. This will be stamped onto the bottom end or around the flange or trunnion.

example:

100-70-SK001

Ram bore and rod size in mm

Seal Kit style number:

SK001 Standard DAM rams without damping (25 to 125 bore) DAM0, DAM1, DAM16, DAM17, DAM32, DAM33, DAM48, DAM49, DAM64, DAM65, DAM80, DAM81, DAM96, DAM97. **SK024** Std 160 bore; **SK025** Std 200 bore.

SK010 Standard DAM rams with damping both ends DAM10, DAM11, DAM42, DAM43 (all sizes).

INSTALLATION & MAINTENANCE ▶

1. Storage

Port plugs must always be left in until pipe connections are to be made. Rams should be oiled and stored in a clean dry atmosphere. They should be vertical to prevent seal set and should not be stored for in excess of 24 months without manufacturers overhaul.

2. Installation

Piping must be thoroughly cleaned and deburred before connection. Sealing agents such as hemp and putty must not be used. Ensure all moving surfaces are correctly lubricated. Rams must be installed free from bending forces and side loads. Initially the system should be cycled at low pressure. All air must be bled from the system to ensure satisfactory function. This may be carried out by cracking pipe joints at the highest points in the system. Only agreed types and grades of fluid may be used.

3. Maintenance

Good fluid conditions is essential for maximum ram life. Contaminated or aged fluid should be replaced, not topped up. If the rod or bore shows signs of marking the unit should be returned to the manufacturer for overhaul. Seal life is dependent on working conditions, particularly the fluid condition, working atmosphere, temperature and speed. Impulse and shock pressures are especially inclined to reduce seal life. Ensure system pressure is dumped and loads are otherwise supported before attempting maintenance. Rams should be thoroughly cleaned prior to reassembly. Abrasive dust and chemicals should not be allowed on, or around, the piston rod as this will advance seal wear and may initiate rod corrosion.