

T- filter



Description

This T- filter provides protection in hydraulic systems up to 350 bar. It is similar to filter models FIL-52; FIL-53 and FIL-54 in design and performance, with the added advantage of an element that can be removed for cleaning or replaced without breaking line connections. This is achieved by unscrewing the filter access cap.

The anodized aluminium housing is lightweight. The standard bronze element filter is 10 micron.

Operating temperatures: 0°C to 100°C

Dimensions

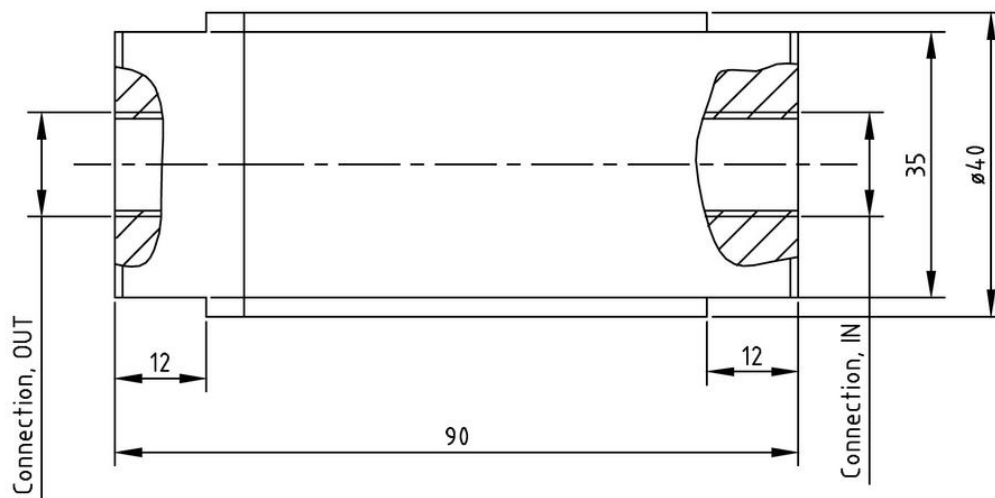
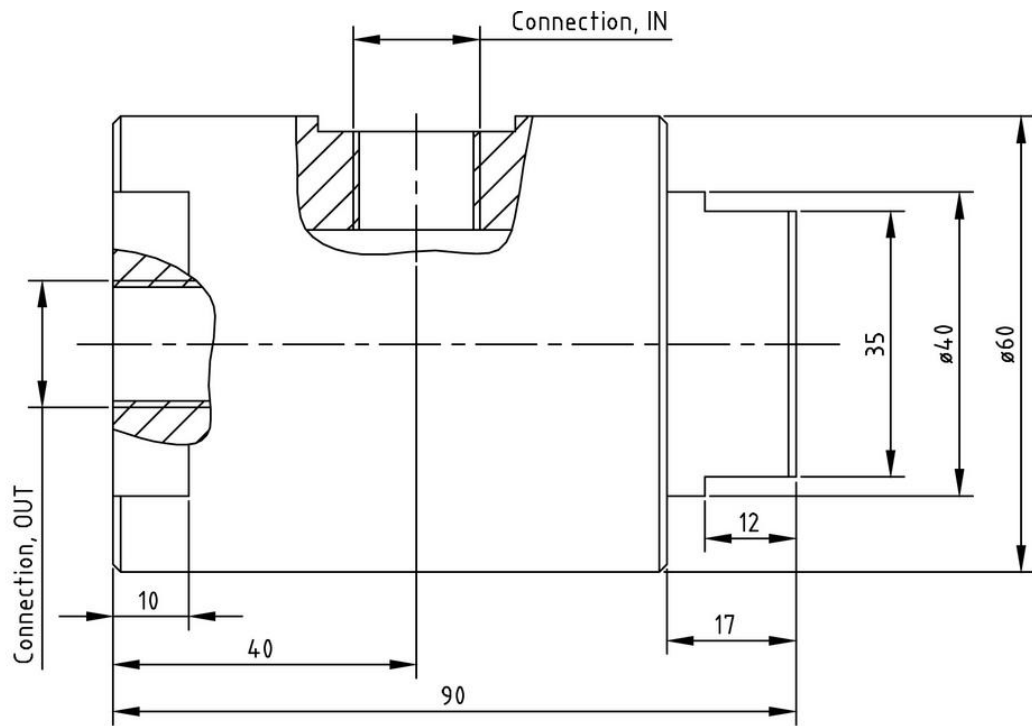

0-125x

Function diagram

Ordering

Order no.	In / Out	Overall length	Dia.	Weight	Max. pressure	Element and seal
FIL-52T-10	1/4" BSP	90 mm	60 mm	0.55 kg	350 bar	FIL- KIT-10
FIL-53T-10	3/8" BSP	90 mm	60 mm	0.55 kg	350 bar	FIL- KIT-10
FIL- KIT-10	-	-	-	-	-	-