

Tank Breather Filter with Filler Strainer ELF up to 5500 l/min

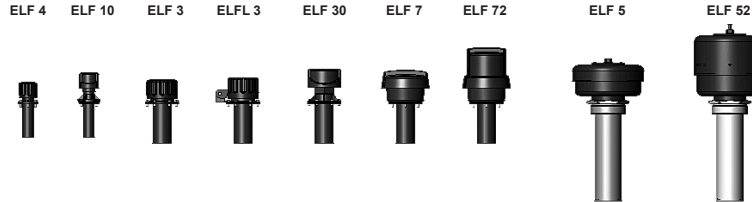

1. TECHNICAL SPECIFICATIONS

1.1 FILTER HOUSING

Construction

Tank breather filters size 4, 10, 3 and 30 consist of an air filter top, which is connected to the mounting flange by a bayonet plate or a threaded boss, and a filler strainer.

Sizes 5 and 52 consist of a two-part threaded air filter top, with built-in oil mist trap, one or two exchangeable filter element(s) and a filler strainer.

Sizes 7 and 72 consist of a two-part flanged filter top, an exchangeable filter element and a filler strainer.

1.2 FILTER ELEMENTS

Contamination retention capacities in g

	Paper
ELF	3 µm
4	2.9
10	2.9
3	6.2
30	6.2
7	26.1
72	52.2
5	85.1
52	170.2

The filter elements are made from phenolic resin impregnated paper and cannot therefore be cleaned.

1.3 FILTER SPECIFICATIONS

Temperature range	-30 °C to +100 °C
Material of housing	Steel, zinc-plated/plastic coated (ELF 4, 3), steel (ELF 5, 52) glass fibre reinforced synthetic material (ELF 10, 30, 7, 72)
Material of filler strainer	Synthetic: ELF 10, 4, 30, 3, 7, 72 Metal: ELF 5, 52
Type of clogging indicator	VMF (return line indicator)
Pressure setting of clogging indicator	0.6 bar K pressure gauge 0.035 bar UBM indicator (others on request)

1.4 SEALS

NBR (= Perbunan) on filter
NBR / Polyurethane on element
Cardboard on mounting flange

1.5 SPECIAL MODELS AND ACCESSORIES

- lockable model (only ELFL 3)
- with check/bypass valve to support the suction characteristics of the pump Not 100% air-tight or leakage-free! (only ELF 10, 3, 30, 5 and 52)
- with anti-splash device (only ELF 10, 3, 30, 7, 72)
- with connection for a clogging indicator (only ELF 7, 72)
- with filler adapter for automotive applications (only ELF 7 and 72) - see Point 5.

1.6 SPARE PARTS

See Original Spare Parts List

1.7 CERTIFICATES AND APPROVALS

On request

1.8 COMPATIBILITY WITH HYDRAULIC FLUIDS ISO 2943

The standard models are suitable for use with mineral and lubrication oils. For fire-resistant and biodegradable oils, see tables:

Fire-resistant fluids

ELF	HFA	HFC	HFD-R
4, 3, 5, 52	-	-	-
10, 30, 7, 72	●	●	-

- HFA oil in water emulsion (H₂O content ≥ 80%)
- HFC water polyglycol solution (H₂O content 35-55%)
- HFD-R synthetic, water-free phosphate ester

Biodegradable fluids

ELF	HTG	HE	HPG
			PAG PRG
all sizes	+	+	● ●

+ suitable for all
● contact our Technical Sales Department
- nicht einsetzbar

- HTG vegetable oil based hydraulic fluids
- HE ester-based synthetic hydraulic fluids
- HPG polyglycol-based synthetic hydraulic fluids
- PAG sub-group HPG: polyalkylene glycol
- PEG sub-group HPG: polyethylene glycol

1.9 CHANGING INTERVALS

The filter elements or filters must be replaced as frequently as the fluid filters, but at least every 12 months.

Symbol

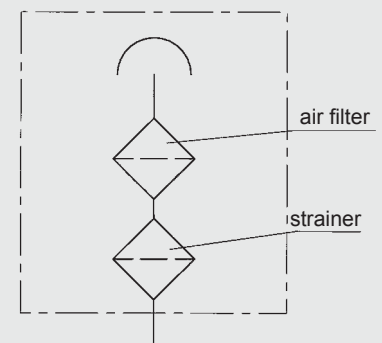

2. MODEL CODE (also order example)

2.1 COMPLETE FILTER

2.1.1 ELF 4, 10, 3, 30 and ELFL 3

ELF P 30 F 3 W 1 . X /-RV0.4

Filter type _____

ELF
ELFL (lockable)

Filter material _____
P Paper

Size _____
ELF 4, 10, 3, 30
ELFL 3

Type and size of connection _____

	Filter size			
	4	10	3	30
F = Flange	●	●	●	●

Filtration rating in µm _____

P 3 (absolute)

Type of clogging indicator _____

W without port, no clogging indicator

Type code (TKZ) _____

Filter size	Code	Δp [bar]
ELF 4	1.X	-
ELF 10	1.X	-
ELF 3	1.X	-
ELF 3.../-RV	4.X	0.4
ELF 3.../-RV	5.X	0.7
ELF 3.../-RV	6.X	0.2
ELF 3.../-RV	7.X	1.0
ELF 30	1.X	-

Modification number _____

X the latest version is always supplied

Supplementary details _____

AS anti-splash without check/bypass valve (not ELF 3 & 4)

RV check/bypass valve (not ELF 4)

RV0.2 } valve with relevant cracking pressure
RV0.4 } (only ELF 10 and 30)
RV0.7 }

SO148 metal filler strainer, 200 mm long (only ELF 3 and 30)

SO175 metal filler strainer, 100 mm long (only ELF 3 and 30)

2.1.2 ELF 7 and 72

ELF P 72 F 3 W 1 . X /-SO148

Filter type _____

ELF

Filter material _____
P Paper

Size _____
ELF 7, 72

Type and size of connection _____

	Filter size	
	7	72
F = Flange DIN 24557/Pt 2	●	●

Filtration rating in µm _____

P 3 (absolute)

Type of clogging indicator _____

W without port, no clogging indicator
K pressure gauge (measuring range
-1 to +0.6 bar) (not for ELF 72)

UBM visual/analogue vacuum gauge
with manual reset
(pressure setting: -0.035 bar)

Type code (TKZ) _____

0 for type UBM
1 for types W and K

Modification number _____

X the latest version is always supplied

Supplementary details _____

AS anti-splash without check/bypass valve
(only ELF 7, 72 without check/bypass valve)

SO148 metal filler strainer, 200 mm long

SO175 metal filler strainer, 100 mm long

SO394 ELF filter without strainer

2.1.3 ELF 5 and 52

ELF P 52 G 3 W 2 . X /-RV0.4

Filter type _____

ELF

Filter material _____

P Paper
BN Betamicron®

Size _____

ELF 5, 52

Type and size of connection _____

	Filter size	
	5	52
G = Thread	G1 1/2	● ●
	G2	● ●
	G2 1/2	● ●
	G3	● ●

Filtration rating in µm _____

P 3 (absolute)

BN 3 (absolute)

Type of clogging indicator _____

W without port, no clogging indicator

Type code (TKZ) _____

Code Connection

2.X G 2½

3.X G 3

4.X G 2

5.X G 1½

Modification number _____

X the latest version is always supplied

Supplementary details _____

RV0.4 check/bypass valve with 0.4 bar pressure setting

SO479 filter suitable for HFC fluids

2.2 REPLACEMENT ELEMENT

0005 L 003 P

Size _____

0005 for ELF 5, 52

0007 for ELF 7

0072 for ELF 72

Type _____

L

Filtration rating in µm _____

P 003

BN 003 (only for 0005)

Filter material _____

P Paper
BN Betamicron®

Replacement elements cannot be ordered for ELF 4, 10, 3, 30 and ELFL 3. These filters are only available complete!

2.3 REPLACEMENT CLOGGING INDICATOR

VMF 0.6 K . X

Type _____

VMF Return line indicator

Pressure setting _____

0.6 -1 to +0.6 bar

0.035 -0.035 bar

Type _____

(see Point 2.1.2)

Modification number _____

X the latest version is always supplied

3. FILTER CALCULATION / SIZING

3.1 SINGLE PASS FILTRATION PERFORMANCE DATA FOR AIR FILTER ELEMENTS

The following separation values were established under real-life simulated conditions.

This means that the selected velocity of the flow against the filter mesh-pack was 20 cm/s and the contamination added was 40 mg/m³ of ISO MTD test dust.

Filtration rating	Retention value d...	For particle size	Filter material
3 µm	d 80	0.74 µm	Paper
	d 100	2.64 µm	

The d 80 value refers to the particle size which is filtered out at a rate of 80% during the retention test. The particle size determined by this method is called the nominal filtration rating of the air filter. The d 100 value therefore refers to the particle size which is filtered out at a rate of 100% during the single pass test. The particle size determined by this method is called the absolute filtration rating of the air filter.

Table of average dust concentrations in real life:

Urban regions with a low level of industry	3-7 mg/m ³ air
General mechanical engineering	9-23 mg/m ³ air
Construction industry (wheeled vehicles)	8-35 mg/m ³ air
Construction industry (tracked vehicles)	35-100 mg/m ³ air
Heavy industry	50-70 mg/m ³ air

3.2 DIFFERENTIAL PRESSURE ACROSS BREATHER FILTER

The differential pressure (with clean element) for the various filter sizes is shown in the graphs under Point 3.4.

3.3 SIZING GUIDELINES

The rate at which contamination enters a hydraulic system can be considerably reduced by using efficient tank breather filtration.

CAUTION:

Incorrectly sized tank breather filters can place additional strain on the system and reduce the service life of hydraulic filter elements.

For optimum sizing the following should therefore be observed:

- Filtration rating of breather filter ≤ filtration rating of hydraulic filter
- Only use breather filters with an absolute retention rate ($d_{100} \leq x \mu\text{m}$; $x =$ given filtration rating)
- Max. permitted initial pressure drop: 0.01 bar (with a clean filter element and at calculated air flow)
- Determining the calculated air flow:

$$Q_A = f_5 \times Q_p$$

$$Q_A = \text{calculated air flow in l}_N/\text{min}$$

$$f_5 = \text{factor for operating conditions}$$

$$Q_p = \text{max. flow rate of the hydraulic pump in l/min}$$

Ambient conditions	Factor f5
Low dust concentration; filter fitted with clogging indicator; continuous monitoring of the filter	1-2
Average dust concentration; filter without clogging indicator; intermittent monitoring of the filter	3-6
High dust concentration; filter without clogging indicator; infrequent or no monitoring of the filter	7-10

3.4 AIR FLOW RATE

ELF 4

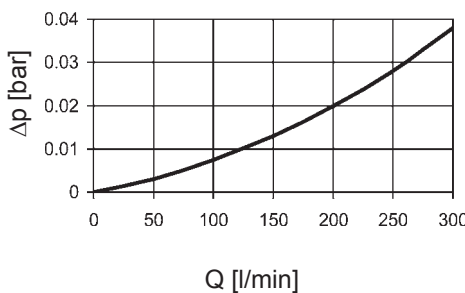

ELF 10

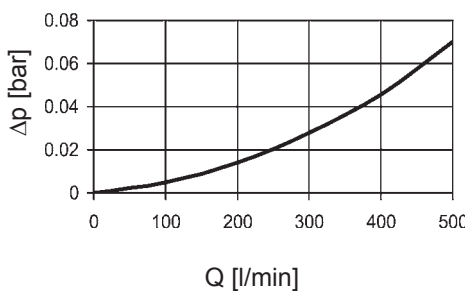

ELF 3

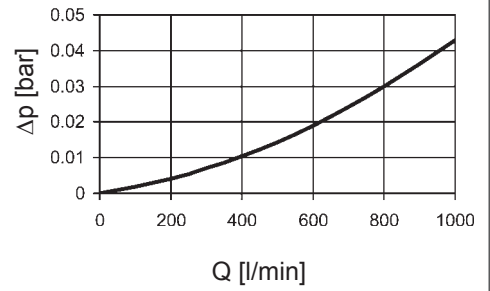

ELF 30

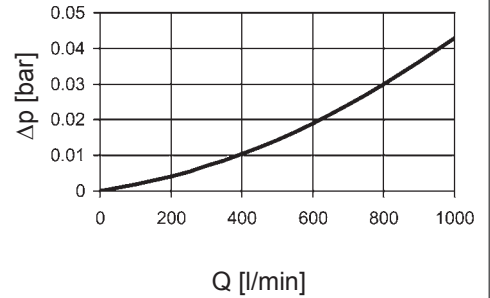

ELF 7

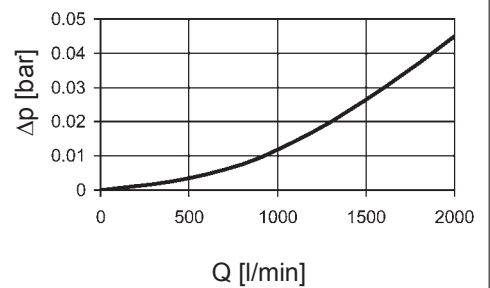

ELF 72

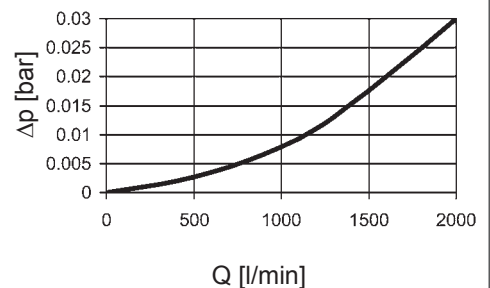

ELF 5

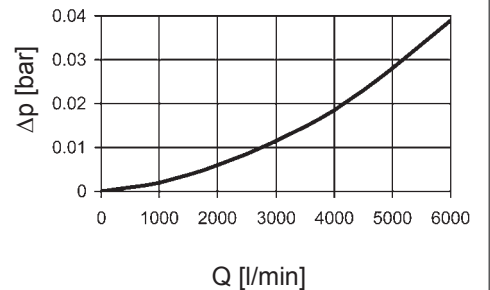

ELF 52

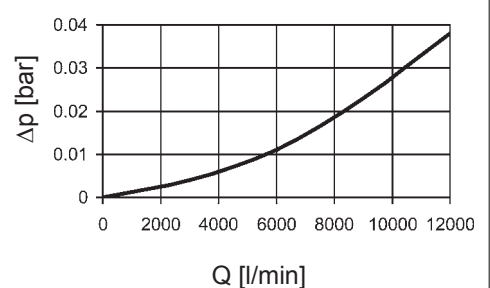

4. DIMENSIONS

ELF 4

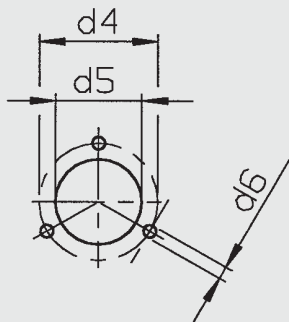
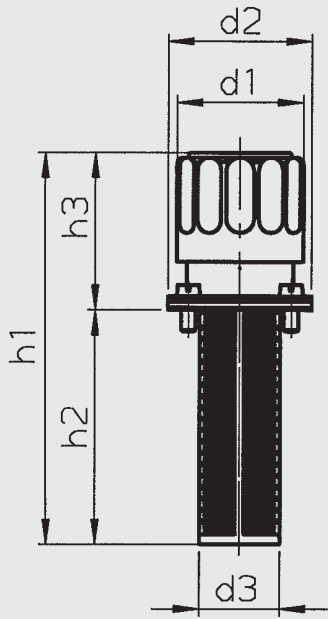

Interface

	ELF 4...
d1	44
d2	50
d3	28
d4	41.3
d5	30
d6	4.5
h1	135
h2	81.5
h3	53.5
Weight	0.20 kg

ELF 10

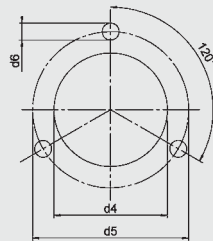
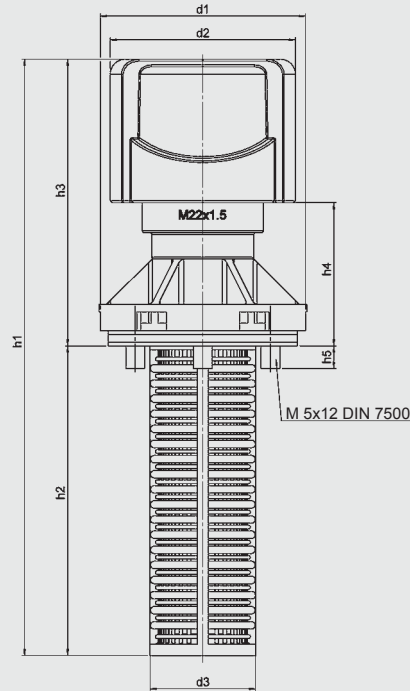

Interface

	ELF 10...
d1	54
d2	49
d3	28
d4	30
d5	41.3
d6	4.5
h1	158
h2	82
h3	76
h4	38
h5	6
Weight	0.08 kg

ELF 3

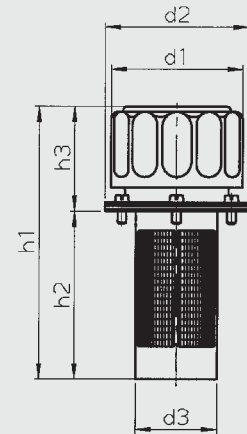

ELFL 3

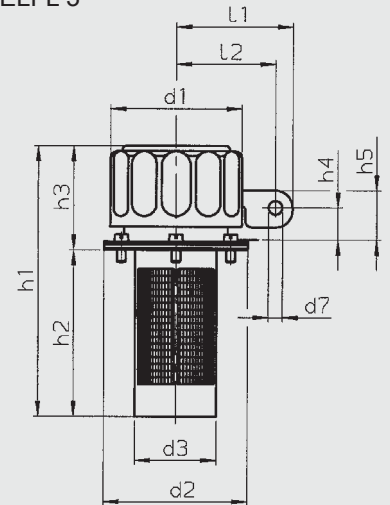

Interface to DIN 24557/Part 2

	ELF 3.../ELFL 3...
d1	76
d2	83
d3	49
d4	73
d5	60
d6	4.5
d7	8
h1	159
h2	96.5
h3	61.5
h4	21
h5	31
l1	67.5
l2	57.5
Weight	0.25 kg

ELF 30

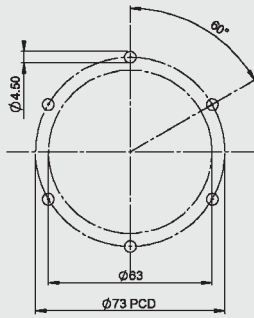
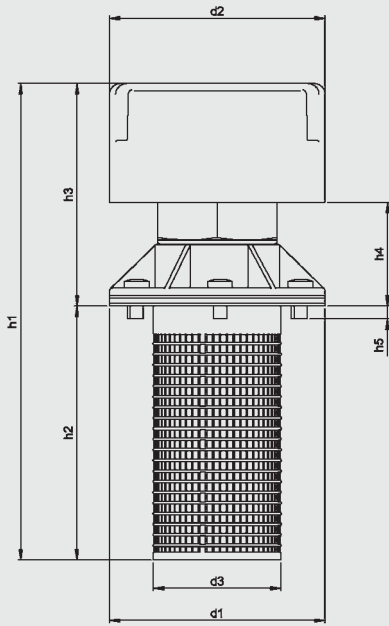

Interface to DIN 24557/Part 2

	ELF 30...
d1	83
d2	83
d3	49
h1	185
h2	100
h3	85
h4	40
h5	5
Weight	0.23 kg

ELF 7

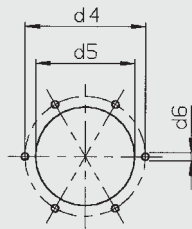
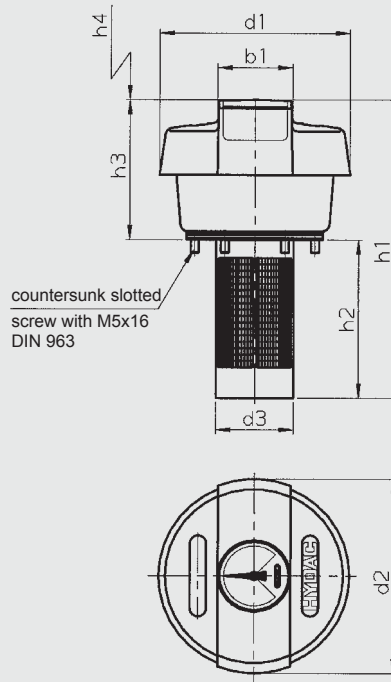

Interface to DIN 24557/Part 2

	ELF 7...
d1	116
d2	120
d3	47
d4	73
d5	60
d6	M5
h1	181
h2	97
h3	84
h4	60
b1	44
Weight	0.38 kg

ELF 72

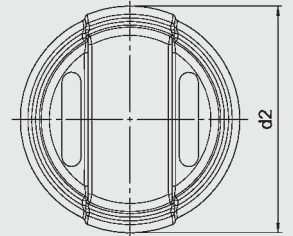
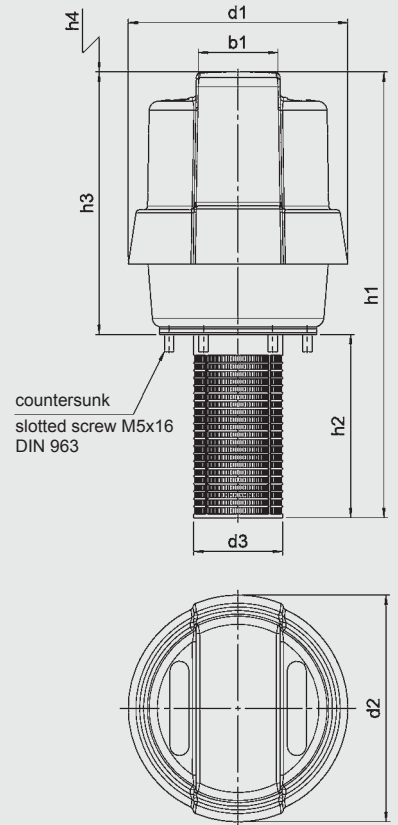

Interface to DIN 24557/Part 2

	ELF 72...
d1	116
d2	120
d3	47
d6	M5
h1	236
h2	97
h3	139
h4	60
b1	44
Weight	0.58 kg

ELF 5

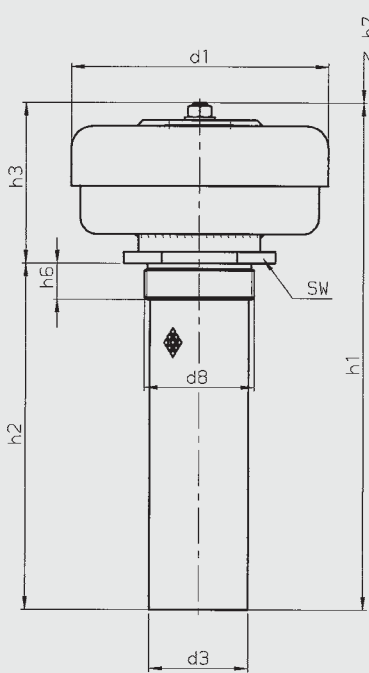

ELF 52

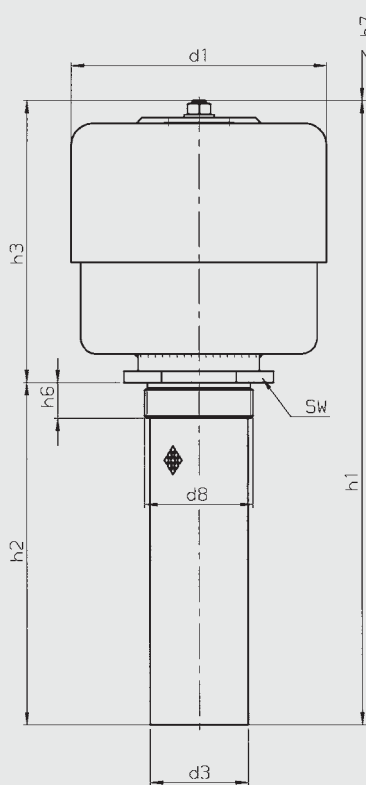

5. FILLER ADAPTER

This adapter can only be used on ELF 7 and ELF 72 filters!

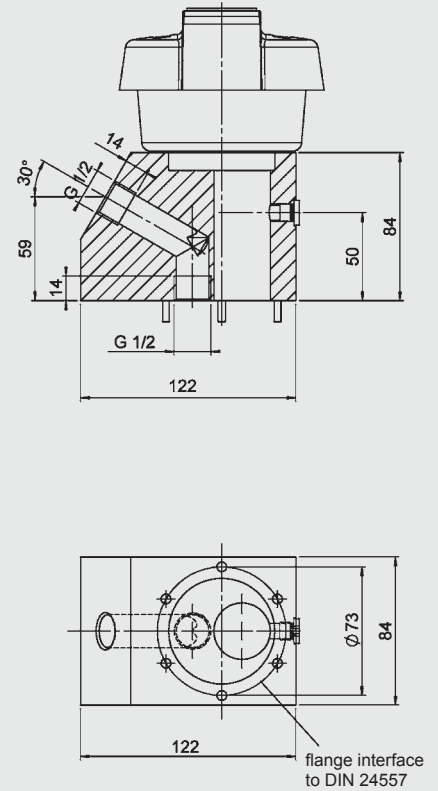

	ELF 5...	ELF 5... /-RV
d1	177	
d8 / d3	...2.X	G 2½ / 70.5
	...3.X	G 3 / 70.5
	...4.X	G 2 / 51.5
	...5.X	G 1½ / 41.5
h1	350	360
h2	240	
h3	105	126
h6	25	
h7	90	
SW	90	
Weight	...2.X	2.70 kg
	...3.X	3.10 kg
	...4.X	2.70 kg
	...5.X	2.60 kg

	ELF 52...	ELF 52... /-RV
d1	177	
d8 / d3	...2.X	G 2½ / 70.5
	...3.X	G 3 / 70.5
	...4.X	G 2 / 51.5
	...5.X	G 1½ / 41.5
h1	416	438
h2	240	
h3	176	198
h6	25	
h7	125	112
SW	90	
Weight	...2.X	3.10 kg
	...3.X	3.50 kg
	...4.X	3.10 kg
	...5.X	3.00 kg

These filler adapters are available in the following threaded connections:

- Adapter ELF /-FA12 (G ½)
(Part No.: 00318597)
- Adapter ELF /-FA34 (G ¾)
(Part No.: 01282563)
- Adapter ELF /-FA1 (G 1)
(Part No.: 01274065)

NOTE

The information in this brochure relates to the operating conditions and applications described.
For applications or operating conditions not described, please contact the relevant technical department.
Subject to technical modifications.

HYDAC FILTERTECHNIK GMBH
Industriegebiet
D-66280 Sulzbach/Saar, Germany
Tel.: 0 68 97 / 509-01
Fax: 0 68 97 / 509-300
Internet: www.hydac.com
E-mail: filter@hydac.com