

Zero point clamping system **SPEEDY airtec 1**



Start/Stop

Lap/Reset

Mode

GO_SPEEDY

00...10...20...30...40..

AIRTEC 1



STARK

GO!

Maximum productivity

- Using the zero point clamping system SPEEDY classic you will increase your productivity to a maximum. Adjustment and checking processes are no longer necessary at all, which means more efficiency and precision in your production.
- With SPEEDY classic, set-up work on your manufacturing machinery is easily undertaken.

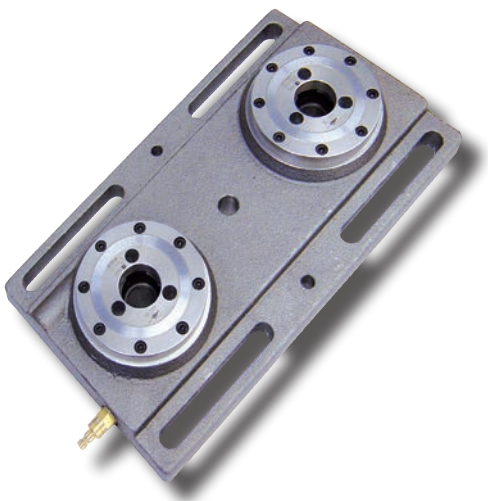
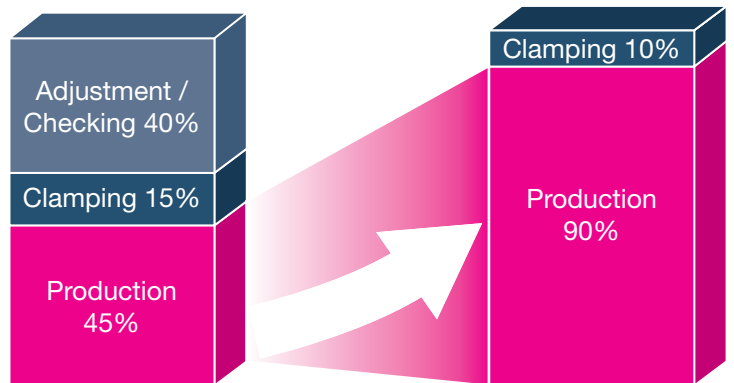

Maximum flexibility

- SPEEDY airtec has a common interface. As a result all equipment can be used on all machines.

Maximum machine availability

- Machining can be interrupted for rush jobs and completed later without loss of time.

SPEEDY airtec – an investment, that will pay for itself in a very short time.



STARK clamping systems overview

Differentiation is by the method of actuation and varying size of the retractable nipples:

SPEEDY classic – clamp mechanically / release hydraulically

Most complete and versatile zero point clamping system.

- Four sizes and numerous variants

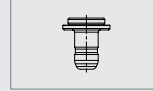
**SPEEDY classic 1**

Catalogue order no. WM-020-304-en

**SPEEDY classic 2**

Catalogue order no. WM-020-277-en

**SPEEDY classic 3**

Catalogue order no. WM-020-279-en

**SPEEDY classic 4**

Catalogue order no. WM-020-281-en

SPEEDY metec – clamp / release mechanically

Robust mechanical zero point clamping system for simple, low cost solutions.

- Three sizes

**SPEEDY metec 1**

Catalogue order no. WM-020-283-en

**SPEEDY metec 2**

Catalogue order no. WM-020-283-en

**SPEEDY metec 3**

Catalogue order no. WM-020-283-en

SPEEDY airtec – clamp mech. / release pneum.

Pneumatic zero point clamping system.

- One size and numerous variants

**SPEEDY airtec 1**

Catalogue order no. WM-020-289-en

SPEEDY hydratec – clamp / release hydraulically

Hydraulic, double-action zero point clamping system for very high clamping speeds.

- One size and numerous variants

**SPEEDY hydratec 1**

Catalogue order no. WM-020-291-en

system 3000 – clamp / release hydraulically

Double-action zero point clamping system with small size and high clamping force.

- One size and numerous variants

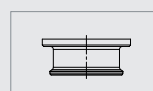
**system 3000**

Catalogue order no. WM-020-066-en

system 4000 – custom systems

Flexible zero point clamping system for mechanical, pneumatic and hydraulic applications.

- One size and numerous variants

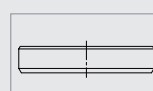
**system 4000**

Catalogue order no. WM-020-067-en

Table of Contents SPEEDY airtec 1

Information		
	STARK clamping systems overview i.4
	Table of contents SPEEDY airtec 1 i.5
	Technical data – transparency from the start i.6
	Technical data – tilting torque calculation example i.7
	Function description SPEEDY airtec 1 –	
	Positioning and clamping in one function i.8
	Proven technology with a system – orig. down to the smallest detail 1.9
		Order no.
SPEEDY airtec 1	STANDARD 155 Flush Mount, bearing ring, ø round 155mm	5000 001 1.1
	STANDARD 100 Flush Mount, bearing ring, ø round 100mm	5000 104 1.2
	STANDARD 100 Flush Mt. module, bearing ring, ø rnd. 100mm	5000 101 1.2
	STANDARD 80 Flush Mount, bearing ring, ø round 80mm	5000 201 1.3
	Practical example 1.4
	STANDARD Surface Mt. housing Surface Mt. with clamping ring	5000 050 1.5
Retractable nipple	With zero point, long collar	5000 009 2.1
	With zero point, short collar	5000 012 2.1
	With equaliser, long collar	5000 010 2.2
	With equaliser, short collar	5000 013 2.2
	Long collar 5000 011	2.3
	Short collar 5000 014 2.3	
	Installation examples – retractable nipple	
	SPEEDY airtec 1 2.4
Nipple fastening	Variant D	804 267 3.1
	Variant E	804 266 3.1
	Practical example, nipple fastening D, E 3.2
Set plate 2	Surface Mount, 2x	5000 710 4.1
	Application with coupling elements 4.2
Accessories	Spanner for installation AF 24	5000 310 5.1
	Torque wrench 5 – 50Nm	804 255 5.1
	Torque wrench 20 – 100Nm	804 256 5.1
	Torque wrench 60 – 300Nm	804 309 5.1
	Spanner for installation for nipple fastening D / E	804 254 5.2
	Slide coupling G1/8", can be switched	5000 300 5.2
	Coupling nipple G1/8"	5000 301 5.2



Technical data – transparency from the start

		STANDARD ø 155mm Order no. 5000 001	STANDARD ø 100mm Order no. 5000 101	STANDARD ø 80mm Order no. 5000 201
Maintenance interval	Cycles	700,000	2,000,000	2,000,000
Clamping force ¹	[N]	20,000	20,000	20,000
Retention force ²	[N]	55,000	55,000	55,000
Release pressure	[bar]	5 – 6	5 – 6	5 – 6
Max. pressure	[bar]	10	10	10
Lateral forces max. allowed	[N]	7,000	7,000	7,000
Tilting torque	[Nm]	800	500	500
Air volume	[cm3]	46	19	19
Operating temperature	[°C]	+10 to +80	+10 to +80	+10 to +80
Min. clamping time allowed	[s]	0.2	0.2	0.2
Min. release time allowed	[s]	0.2	0.2	0.2
Radial pre-positioning ³	[mm]	± 2	± 2	± 2
Max. axial pre-positioning				
automated loading	[mm]	At stop	At stop	At stop
Repeatability ⁴	[mm]	< 0.005	< 0.005	< 0.005
System accuracy ⁵	[mm]	< 0.01 *	< 0.01 *	< 0.01 *
Weight	[kg]	4.80	1.10	1.00

* With appropriate design and adjustments, accuracies in the µ-range are possible.

- ¹ Clamping force** The clamping force refers to the load up to which the zero point is guaranteed. The clamping force stated must not be exceeded.
- ² Retention force** The retention force refers the max. overload at which the nipple will continue to be retained, but the zero point has already been left (designed for M12 screw).
- ³ Radial pre-positioning** The loading device must have play in the case of automated handling.
- ⁴ Repeatability** Repeatability generally refers to the accuracy with which the same pallet is positioned on changing on the same interface.
- ⁵ System accuracy** System accuracy refers to the accuracy resulting from changing several pallets, e.g. on different machines.

Technical data – tilting torque calculation example

profit from our specialist competence

**Example:**

Fast closing clamp plate 4x SPEEDY airtec 1 with 200 x 200 spacing and max. feed force of 7 kN with distance of 400 mm.

Question:

Due to the predominance of roughing work, the system is to be checked for double safety. Are the insertion force, number of fast closing clamps and the selected spacing right for this application?

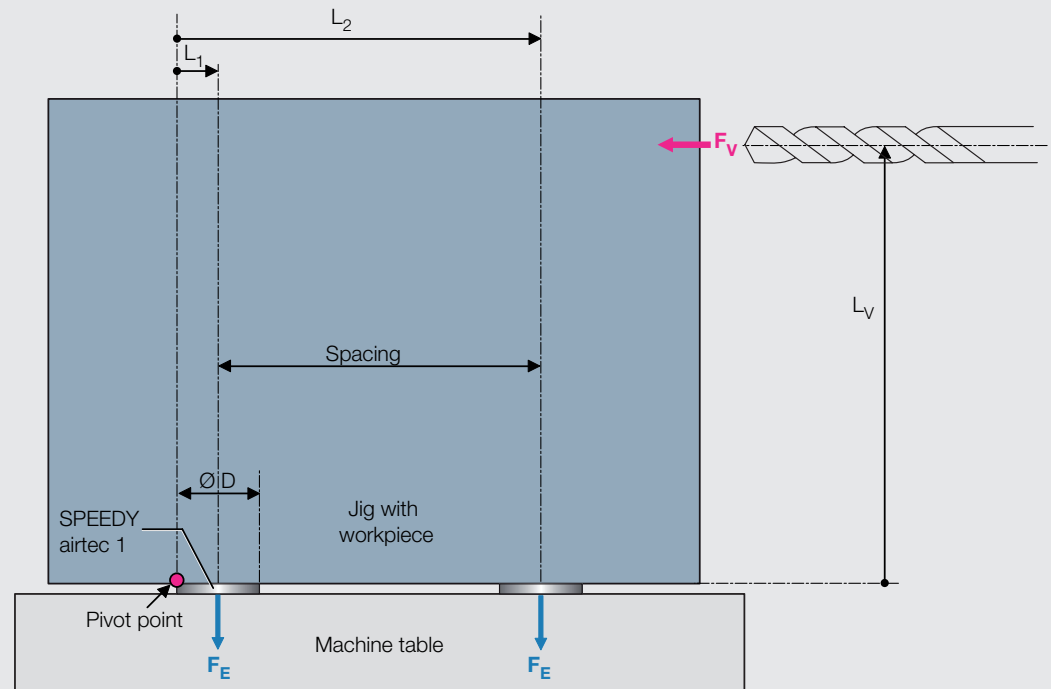
**Solution:**

$$M_E > 2 \times M_V ?$$

$$M_V = F_V \times L_V = 7,000 \text{ N} \times 0.4 \text{ m}$$

$$M_V = \mathbf{2,800 \text{ Nm}}$$

$$M_E = 2 \times (F_E \times L_1) + 2 \times (F_E \times L_2)$$

$$M_E = 2 \times F_E \times (L_1 + L_2)$$

$$L_1 = \text{ØD} / 2$$

$$L_2 = \text{ØD} / 2 + \text{Spacing}$$

$$L_1 + L_2 = \text{ØD} + \text{Spacing}$$

$$L_1 + L_2 = 0.129 \text{ m} + 0.20 \text{ m} = 0.329 \text{ m}$$

$$M_E = 2 \times F_E \times (L_1 + L_2) = 2 \times 20,000 \text{ N} \times 0.329 \text{ m}$$

$$M_E = \mathbf{13,160 \text{ Nm}}$$

$$M_E / M_V > 2 ?$$

$$M_E / M_V = 13,160 \text{ Nm} / 2,800 \text{ N}$$

$$M_E / M_V = \mathbf{4.7 > 2}$$

With this design, safety by around a factor of 4.7 is provided.

(All dimensions to be entered in SI units (metres, Newtons))

M_V : Moment from feed force

M_E : Moment from insertion force

F_V : Feed force (7,000 N)

F_E : Insertion force (20,000 N)

Spacing = 200 mm = 0.20 m

Ø D (Bearing ring) : 129 mm = 0.129 m

L_V : 400 mm = 0.40 m

Function description SPEEDY airtec 1 – positioning and clamping in one function

i

Principle of operation:

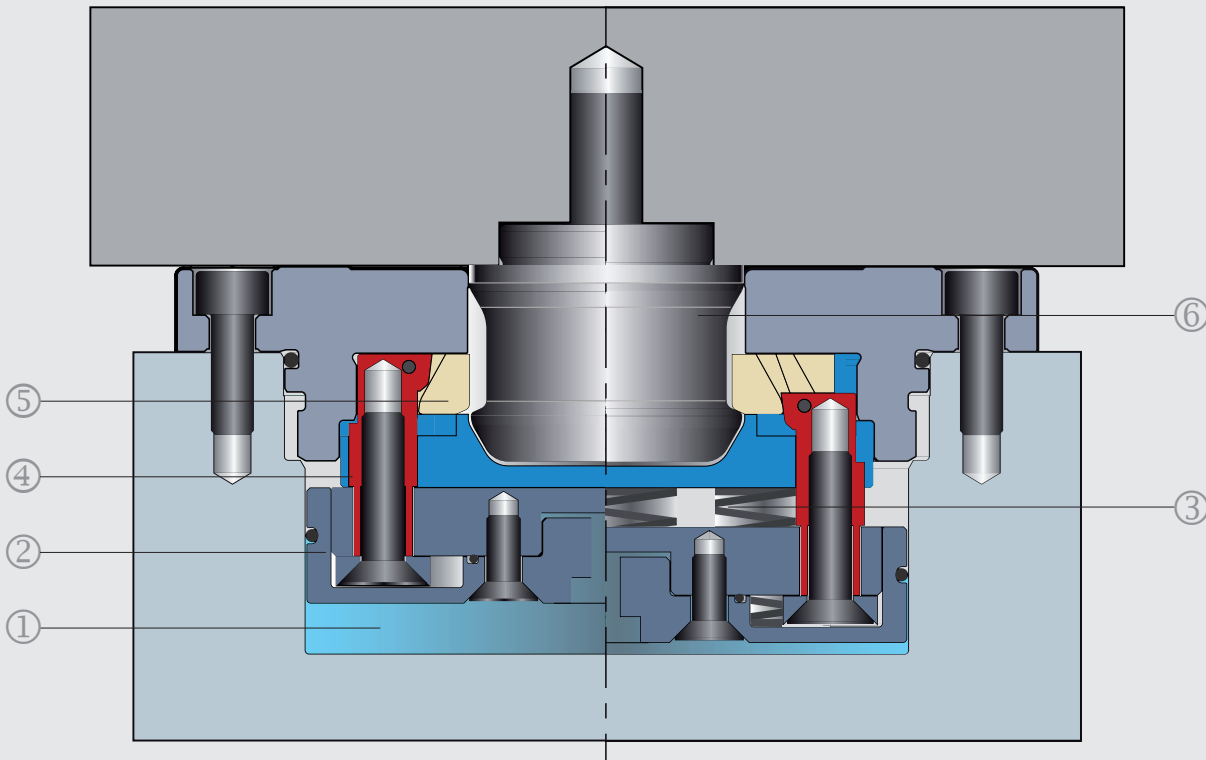

Releasing pneumatically:

- Pneumatic pressure (1) is applied to the piston (2) and the piston moves upward. The spiral springs (3) are pressed together.
- The clamping fingers (4) move upward through the piston (2) and pull the segments (5) to the outside.
- The retractable nipple (6) is released.

Clamping mechanically:

- The pneumatic pressure is relieved. The pneumatic pressure drops to 0bar.
- The spring pre-load is applied via the piston (2), the piston moves downward.
- The clamping fingers (4) are pulled down by the piston (2) and push the segments (5) toward the inside.
- The retractable nipple (6) is pulled down by the clamping face on the segments (5) and clamped against the bearing surface.

Proven technology with system –
original down to the smallest detail

**Advantages
to be worth it!**

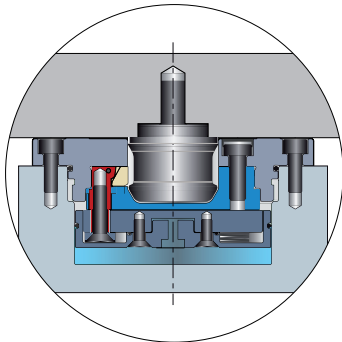

Design

- Compact design (Flush Mount, screw-fit or module)
- High retention force, enormous power density
- Maintenance-free, designed for large number of load changes (> 2 million in continuous test)
- Made of high quality tool steel and chromium steel
- Actuation with clean air, from 5bar to release
- Can be operated without additional service unit
- Environmentally friendly and clean operation (no oil)
- Particularly suitable for oil-free environment, e.g in the foodstuffs, aerospace industry or medical sector.

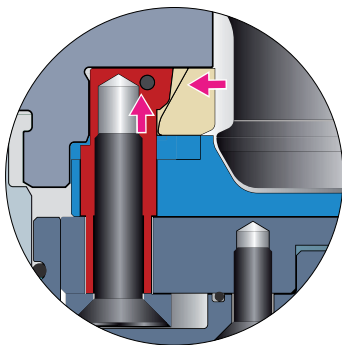

Positive action operation

- The segments are actuated mechanically
- Powerful and secure clamping is ensured at all times
- In an endurance test over 3 million clamping cycles tested, full functionality even under extreme conditions.
- Functions reliably in any installation position
- Very short clamping and release time – 0.2sec

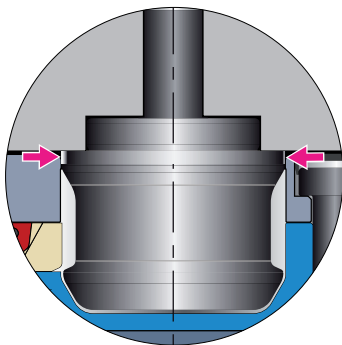

Cylindrical fit

- Due to the cylindrical fit, high lateral forces can be absorbed by the fast closing clamp during the machining
- Ideal pre-centring for Römheld coupling elements without coupling travel, data sheet F9.461

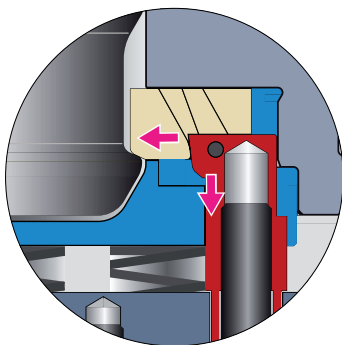

Segments

- Due to the optimal all-round positive clamping action of the clamping segments, the retractable nipple is retained stably and securely in the fast closing clamp.



STANDARD 155

- Flush Mount
- Bearing ring
- Round $\varnothing 155\text{mm}$



Characteristics:

Flush Mount fast closing clamp made of high quality tool steel.

Due to low height little space needed. Can be installed as a module.

Is clamped mechanically and released pneumatically.

Application:

For flush mounting in machine pallets, plates, angles, cubes, towers and swivelling yokes.

Can be used for all common machining tasks such as milling, turning, grinding, eroding as well as on test stands for mounting devices.

Particularly suitable for oil-free environment, e.g in the foodstuffs, aerospace industry or medical sector.

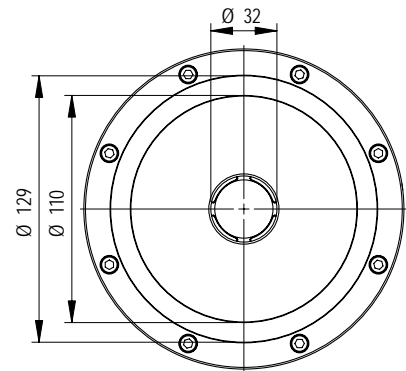
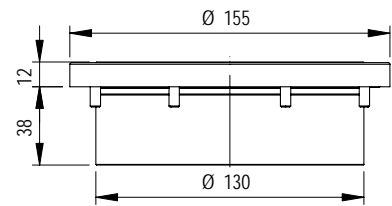

Z 5000 001

Order no.	Retention force	Clamping force	Pressure to release	Weight	Data sheet
5000 001	55,000N	20,000N	5 – 6bar	4.80 kg	D062/066



Practical example:

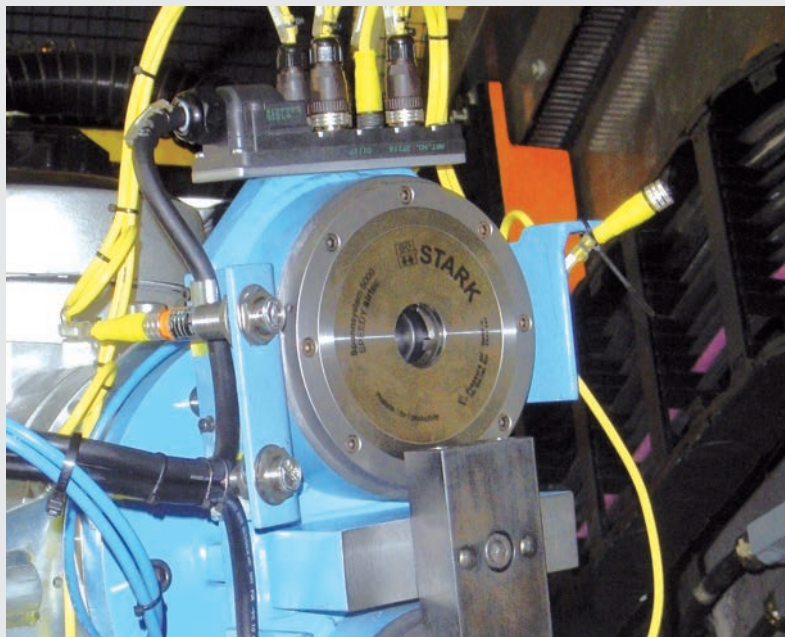

SPEEDY airtec 1 fast closing clamp, built into a robot arm for changing workpieces. Pallet identification and presence check via sensors on the changer arm.

STANDARD 100

- Flush Mount
- Bearing ring
- Round $\varnothing 100\text{mm}$



Characteristics:

Flush Mount fast closing clamp made of high quality tool steel.

Due to low height can be fitted taking up little space from 40mm.

Is clamped mechanically and released pneumatically.

Application:

For flush mounting in machine pallets, plates, angles, cubes, towers and swivelling yokes.
Can be used for all common machining tasks such as milling, turning, grinding, eroding as well as on test stands for mounting devices.

Particularly suitable for oil-free environment, e.g in the foodstuffs, aerospace industry or medical sector.

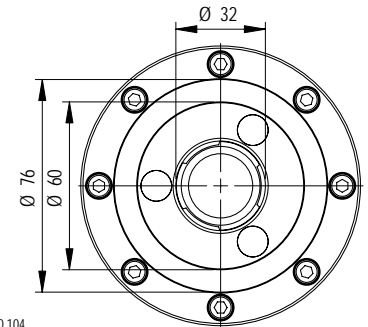
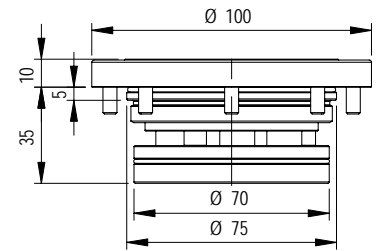

Z 5000 104

Order no.	Retention force	Clamping force	Pressure to release	Weight	Data sheet
5000 104	55,000N	20,000N	5 – 6bar	1.00kg	D074

STANDARD 100

- Flush Mount module
- Bearing ring
- Round $\varnothing 100\text{mm}$

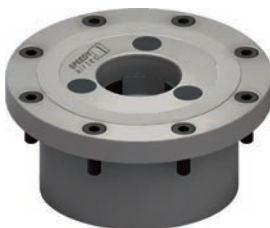

Characteristics:

Flush Mount fast closing clamp made of high quality tool steel.

Due to low height little space needed. Can be installed as module. Can also be used with low wall thickness.

Is clamped mechanically and released pneumatically.

Application:

For flush mounting in machine pallets, plates, angles, cubes, towers and swivelling yokes.
Can be used for all common machining tasks such as milling, turning, grinding, eroding as well as on test stands for mounting devices.

Particularly suitable for oil-free environment, e.g in the foodstuffs, aerospace industry or medical sector.

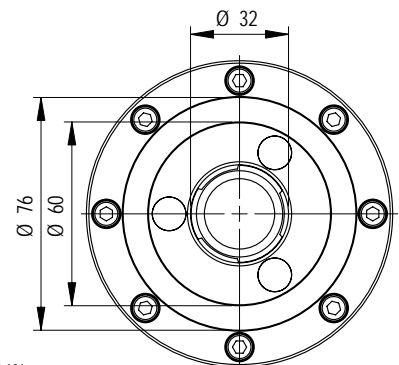
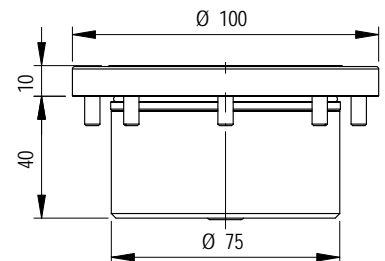

Z 5000 101

Order no.	Retention force	Clamping force	Pressure to release	Weight	Data sheet
5000 101	55,000N	20,000N	5 – 6bar	1.10kg	D088



STANDARD 80

- Screw-fit
- Bearing ring
- Round $\varnothing 80\text{mm}$

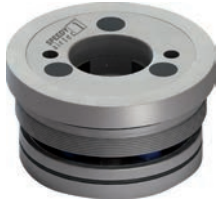

Characteristics:

Flush Mount fast closing clamp made of high quality tool steel.

Due to low height little space needed (can be installed even from plate thickness of 40 mm).

Flush Mount variant with fine thread, suitable spanner for installation order no. 5000 310.

Is clamped mechanically and released pneumatically.

Application:

For flush mounting in machine pallets, plates, angles, cubes, towers and swivelling yokes.

Can be used for all common machining tasks such as milling, turning, grinding, eroding as well as on test stands for mounting devices.

Particularly suitable for oil-free environment, e.g in the foodstuffs, aerospace industry or medical sector.

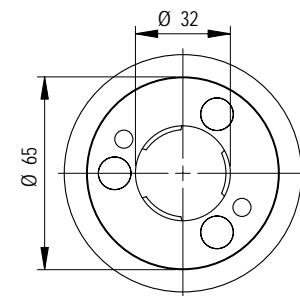
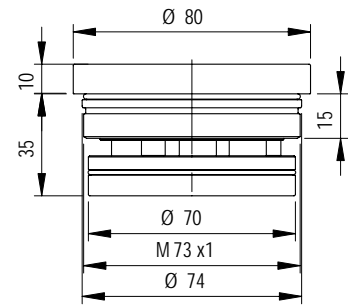

Z 5000 201

Order no.	Retention force	Clamping force	Pressure to release	Weight	Data sheet
5000 201	55,000N	20,000N	5 – 6bar	1.00kg	D073

i**Practical example:**

Jig change in seconds, from machine vice to three-jaw chuck. Simply release pneumatically, change jig and clamp.

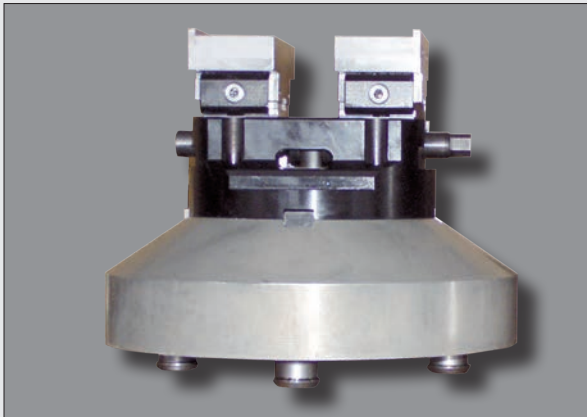

Quick change pallet with machine vice for 5-sided machining.



Quick change pallet with three-jaw chuck for 5-sided machining.

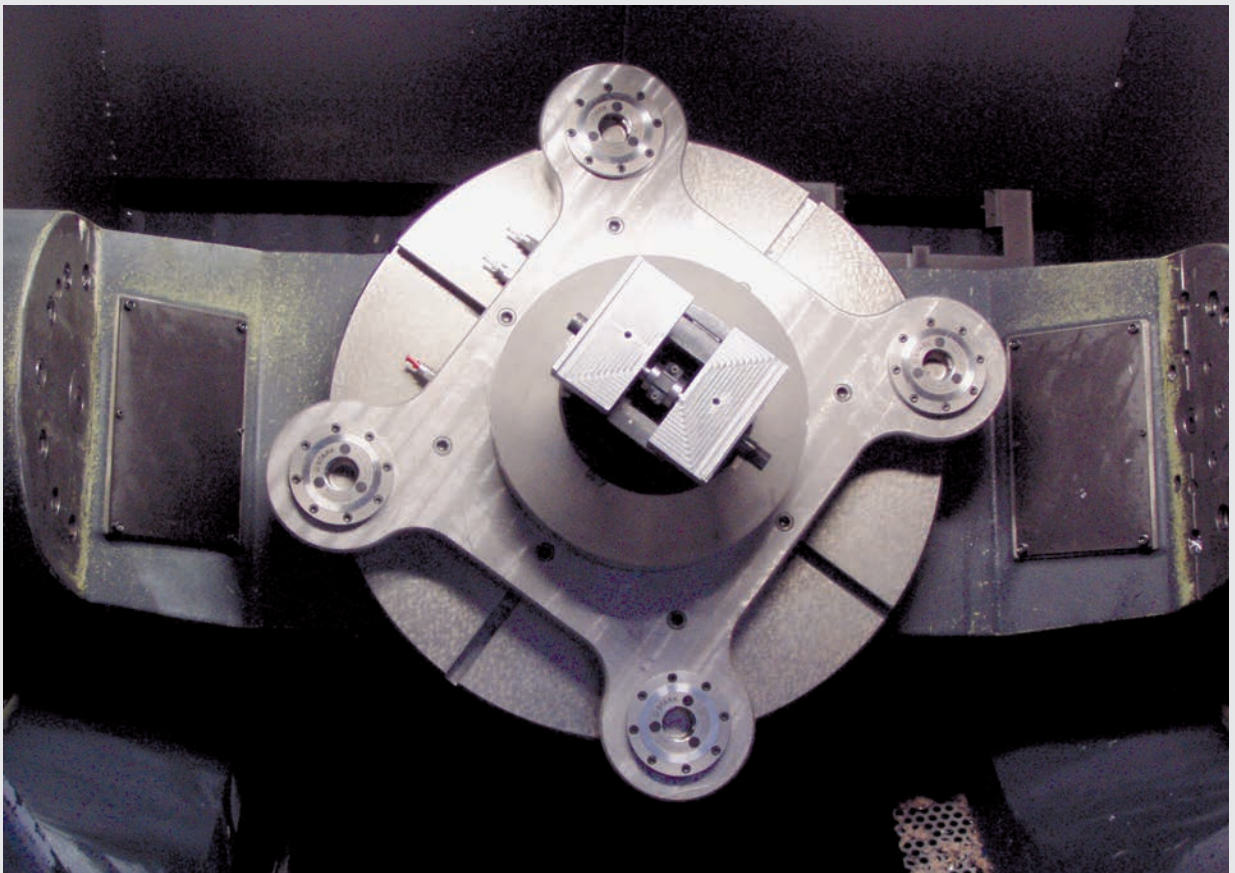

SPEEDY airtec 1 Standard 100, installed in fast closing clamp plate. Customer-specific design with two different spacings for flexible machining – *clamping force of 20kN per fast closing clamp.*

STANDARD Surface Mount housing

- Surface Mount
- With clamping ring



Characteristics:

Fast closing clamp Surface Mount housing made of 1.0570, nitrided, suitable for SPEEDY airtec 5000 001.

Due to low height, low assembly of 50 mm.

Is fastened to the machine table using four screws DIN 912.

Application:

For surface mounting on machine pallets, plates, angles, cubes, towers and swivelling yokes.

Can be used for all common machining tasks such as milling, turning, grinding, eroding as well as on test stands for mounting devices.

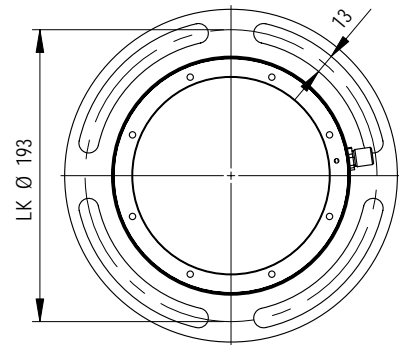
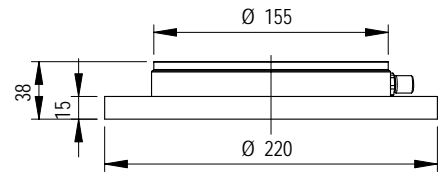

Z 5000 050

Order no.	Weight
5000 050	2.20kg



Practical example:

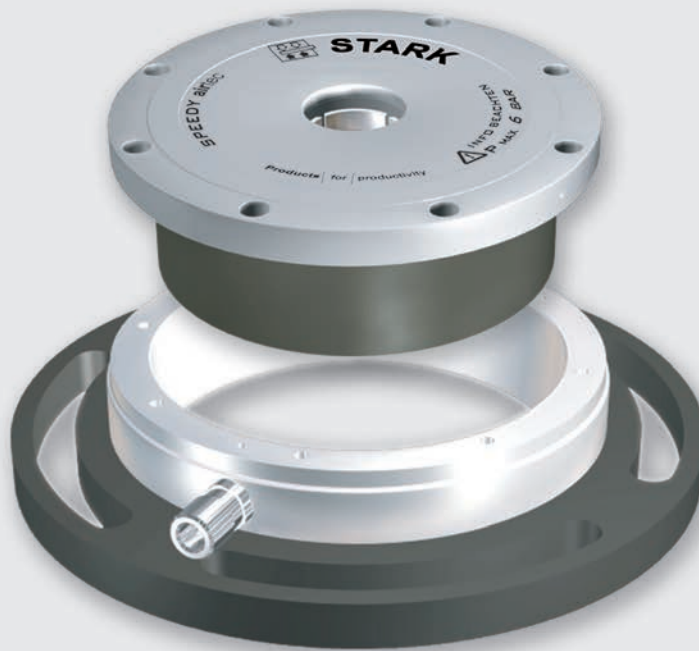

Standard Surface Mount housing SPEEDY airtec 1 with clamping ring and pneumatic connection.



i

Your advantages:

Five workpiece changes without zero point clamping system per shift result in approximately 100 minutes of set-up time. During this time it is not possible to machine any workpieces – the machine is stationary!
With STARK zero point clamping system, the set-up time during a shift is reduced to 20 minutes, that means 80 minutes more machine running time – the machine is producing!

This means approx. 420 hours (!) additional machine capacity per year.

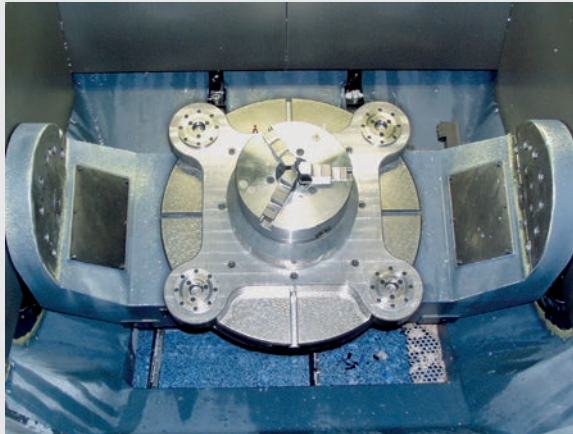

8x quick change pallet with 3-jaw chuck for 5-sided machining, clamped with 4 SPEEDY airtec 1 with 20kN per fast closing clamp.

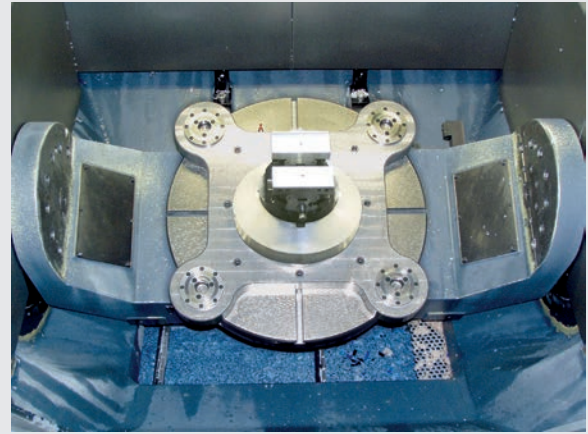

8x quick change pallet with machine vice for 5-sided machining, clamped with 4 SPEEDY airtec 1 with 20kN per fast closing clamp.

From the bottleneck to the production machine:

The Gantt chart shows further advantages:

- Quality assurance parallel to productive time is a crucial factor due to the short set-up time.
- The batch size is less important.
- Rush jobs can be inserted without problems.

Before: bottleneck machine

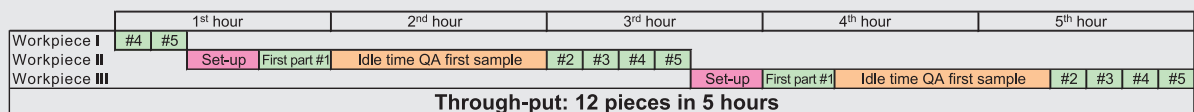

After: production machine (due to shortening of set-up and exact zero point jig change)

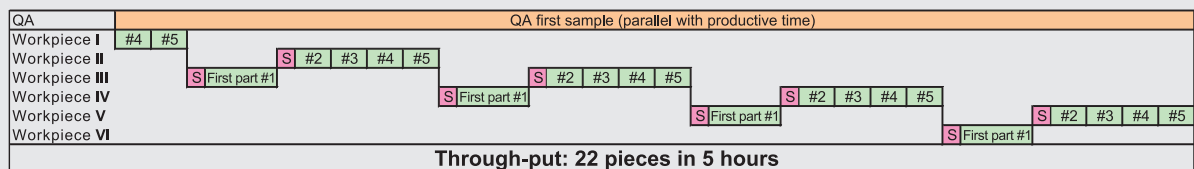

Key:	Unchanged:		
		First part #1	Elapsed time for first part 20 minutes
		#3	Elapsed time per part after QA approval: 10 minutes
		Idle time QA first sample	Idle time until approval available: 60 minutes
	Changed:		
	Before:	Set-up	Set-up time (with screws, sliding blocks, etc.): 20 minutes
	After:	S	Set-up time with STARK zero point clamping system (repeatability 5 µm): 5 minutes
			QA first sample in parallel with productive time



Retractable nipple

- With zero point
- Short collar



Characteristics:

Retractable nipple with zero point.

Application:

For positioning and clamping on machine pallets, machine vices, chucks, jigs, direct workpiece clamping.

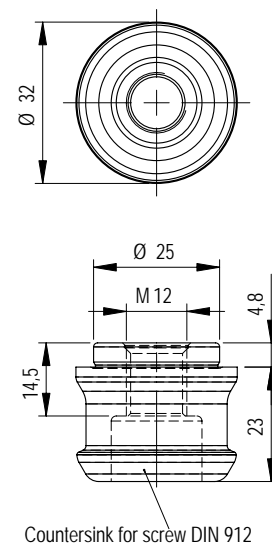

Z 5000 012

Order no.	Screw quality	Tightening torque at the nipple	Tightening torque at the screw	Weight	Data sheet
5000 012	min. 8.8	45Nm	60Nm	0.10kg	D029

Retractable nipple

- With zero point
- Long collar



Characteristics:

Retractable nipple with zero point.

Application:

For positioning and clamping on machine pallets, machine vices, chucks, jigs, direct workpiece clamping.

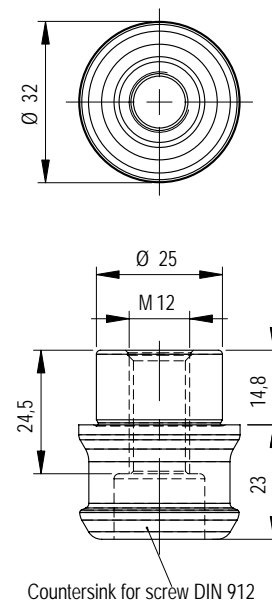

Z 5000 009

Order no.	Screw quality	Tightening torque at the nipple	Tightening torque at the screw	Weight	Data sheet
5000 009	min. 8.8	45Nm	60Nm	0.13kg	D029



Retractable nipple

- With equaliser
- Short collar



Characteristics:

Retractable nipple with equaliser on one axis (sword shape).

Application:

On machine pallets, machine vices, chucks, jigs, direct workpiece clamping.

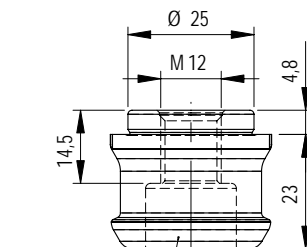
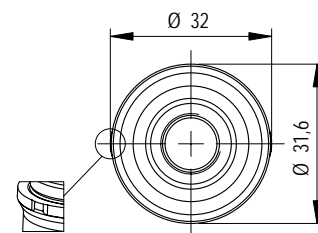

Countersink for screw DIN 912

Order no.	Screw quality	Tightening torque at the nipple	Tightening torque at the screw	Weight	Data sheet
5000 013	min. 8.8	45Nm	60Nm	0.10kg	D029

Retractable nipple

- With equaliser
- Long collar



Characteristics:

Retractable nipple with equaliser on one axis (sword shape).

Application:

On machine pallets, machine vices, chucks, jigs, direct workpiece clamping.

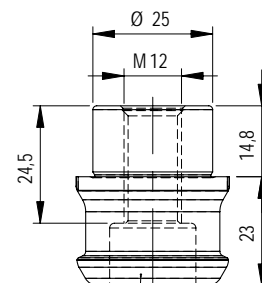
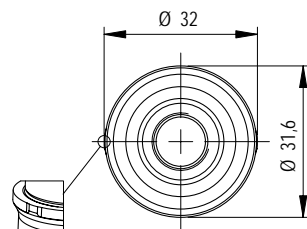

Countersink for screw DIN 912

Z 5000 010

Order no.	Screw quality	Tightening torque at the nipple	Tightening torque at the screw	Weight	Data sheet
5000 010	min. 8.8	45Nm	60Nm	0.13kg	D029



Retractable nipple

● Short collar



Characteristics:

Retractable nipple without centring.

Application:

For secure clamping on machine pallets, machine vices, chucks, jigs, direct workpiece clamping.

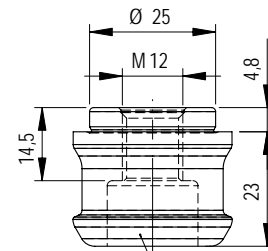
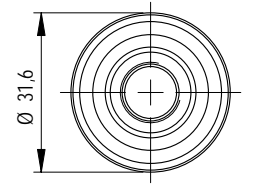

Countersink for screw DIN 912

Z 5000 014

Order no.	Screw quality	Tightening torque at the nipple	Tightening torque at the screw	Weight	Data sheet
5000 014	min. 8.8	45Nm	60Nm	0.10kg	D029

Retractable nipple

● Long collar



Characteristics:

Retractable nipple without centring.

Application:

For secure clamping on machine pallets, machine vices, chucks, jigs, direct workpiece clamping.

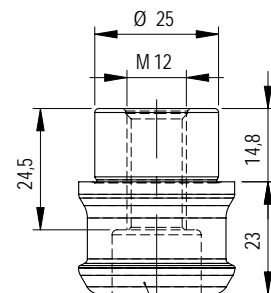
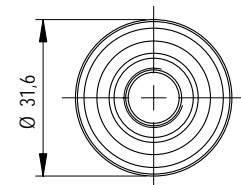

Countersink for screw DIN 912

Z 5000 011

Order no.	Screw quality	Tightening torque at the nipple	Tightening torque at the screw	Weight	Data sheet
5000 011	min. 8.8	45Nm	60Nm	0.13kg	D029

**Product information:**

Installation examples – retractable nipple SPEEDY airtec 1.

Variant A

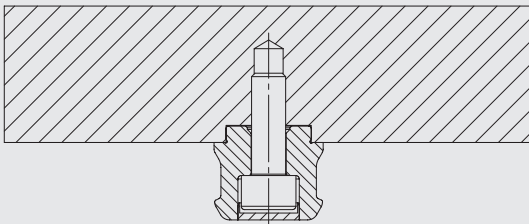

Variant B

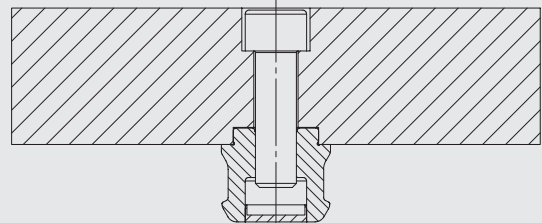

Variant D

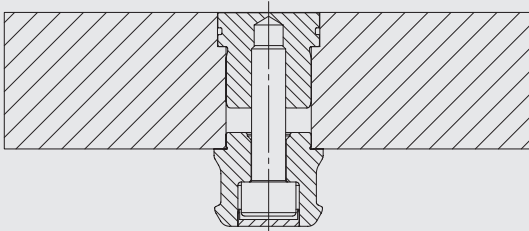

Variant E

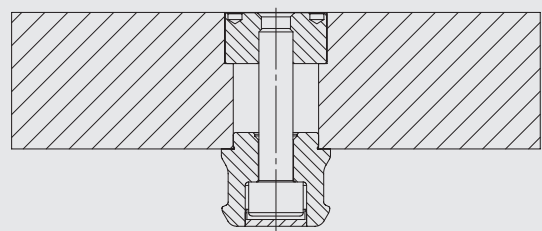

Z 001

- Variant A: For applications in which no nipple bores are allowed on the pallet surface, or for direct workpiece clamping.
- Variant B: Simple nipple fastening from above if accuracy between the position of the nipple and the top of pallet is not especially important.
- Variant D, E: These fastening variants are to be preferred. The precision bore for the nipple and all necessary positioning bores on the pallet can be made in one work step. As a result the accuracy between the positions is very high. For these variants special nipple fastenings (on page 3.1) are available.



Nipple fastening D



Characteristics:

Makes it possible to manufacture the nipple fastening in one work step. As a result the highest accuracy is achieved.

Application:

Machine pallets, machine vices, chucks, jigs, direct workpiece clamping.
Spanner for installation order no. 804 254 (see page 5.2).

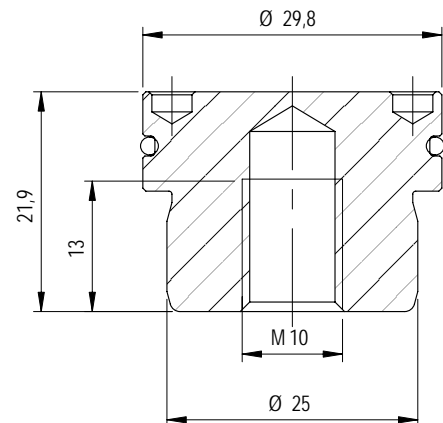

Z 804 267

Order no.	For nipple ø	Tightening torque	Tightening torque	Weight	Data sheet
804 267	25mm	45Nm	60Nm	0.05kg	D029

Nipple fastening E

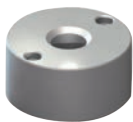

Characteristics:

Makes it possible to manufacture the nipple fastening in one work step. As a result the highest accuracy is achieved.

Application:

Machine pallets, machine vices, chucks, jigs, direct workpiece clamping.
Spanner for installation order no. 804 254 (see page 5.2).

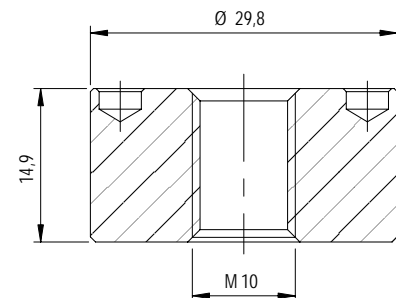

Z 804 266

Order no.	For nipple ø	Tightening torque	Tightening torque	Weight	Data sheet
804 266	25mm	45Nm	60Nm	0.05kg	D029

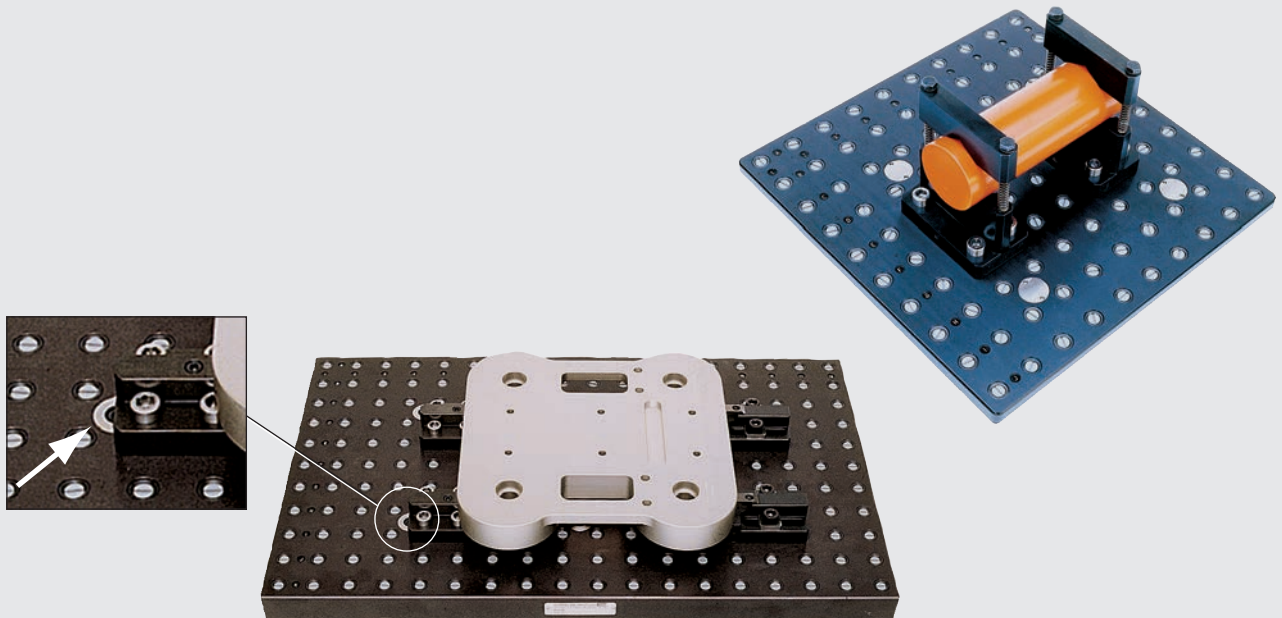
**Practical example:**

Nipple fastening variant D and E. Makes it possible to manufacture the nipple fastening in one work step. As a result the highest accuracy is achieved.



Set plate 2

● Surface Mount

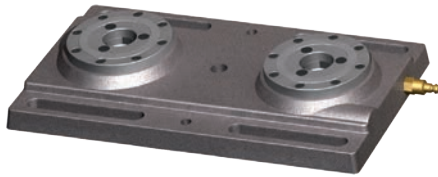

Characteristics:

The set plate 2 can be used on almost any machine table due to the slots and the sliding blocks with pins. Simple alignment is possible due to the precision bores.

The set plates can thus be rapidly and precisely adjusted by the customer to the grid or T slot tables on any machine table.

Application:

For surface mounting on machine pallets, plates, angles, cubes, towers and swiveling yokes.

Can be used for all common machining tasks such as milling, turning, grinding, eroding as well as on test stands for mounting devices.

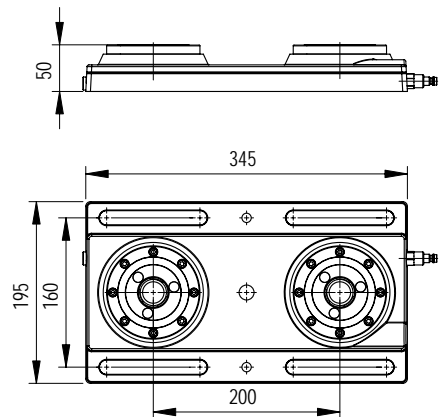

Z 5000 710

Order no.	Retention force*	Clamping force*	Pressure to release	Spacing	Weight
5000 710	55,000N	20,000N	6bar	200mm	15.00kg

* Retention force and clamping force per fast closing clamp SPEEDY airtec.

Set contents

1x set plate 2x
 2x retractable nipples with zero point order no. 5000 012
 2x retractable nipples with equaliser order no. 5000 013



Practical example:

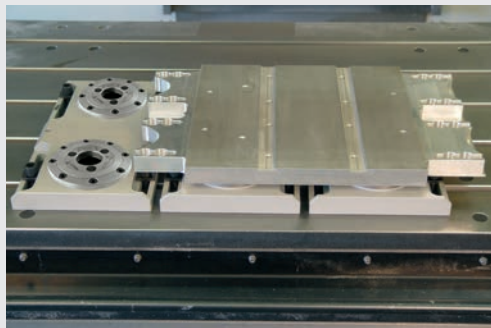

SPEEDY airtec module plate, designed for clamping using 6 fast closing clamps.

**Product information:**

Application with coupling elements that do not require any coupling stroke.
Römheld data sheet F9.461.

- Positioning using SPEEDY airtec retractable nipples (1)
- Automatic coupling during clamping
- Smooth surface (2) – easy to clean the couplings

Advantages
to be worth it!

**Characteristics:**

Coupling elements are used for the provision of hydraulic oil and air, other media on request. The coupling element does not require any coupling stroke, can only be coupled de-pressurised. The necessary positioning is ensured together with the SPEEDY airtec fast closing clamp.

Application:

Coupling elements are used on machine tools with pallet changers to transfer hydraulic oil and compressed air from the machine table to the jigs.



Spanner for installation

- AF 24

Characteristics:

Spanner for installation.

Application:

Installation and removal of
airtec order no. 5000 201.

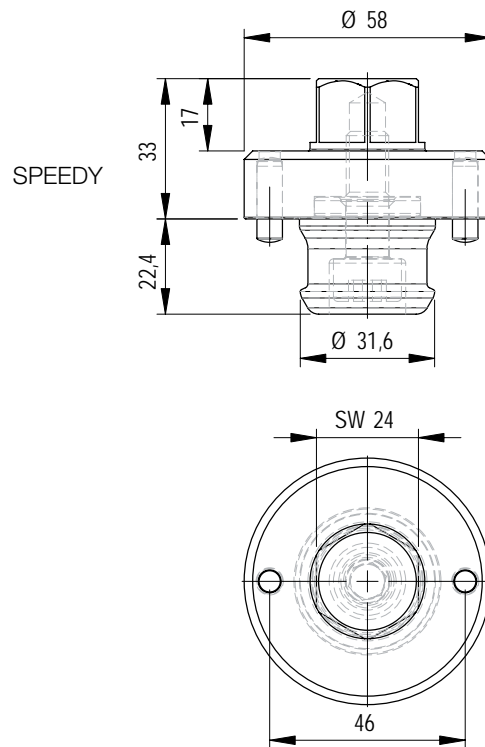

Order no.	Size	Weight
5000 310	AF24	0.60kg

During assembly pay attention to the torque of 250Nm, as per technical information.

Torque wrench

Characteristics:

Adjustable torque wrench.

Application:

Fitting and removing retractable
nipples. Note torque data in the
related operating instructions!

Order no.	Adjusting range	Weight
804 255	5 – 50Nm	0.60kg
804 256	20 – 100Nm	0.90kg
804 309	60 – 300Nm	1.40kg

During assembly pay attention to the torque, as per technical information.

Spanner for installation for nipple fastening D / E



Characteristics:

Spanner for installation for fitting the nipple fastening D / E

Application:

Installation and removal, nipple fastening D / E, order no. 804 267 and 804 266.

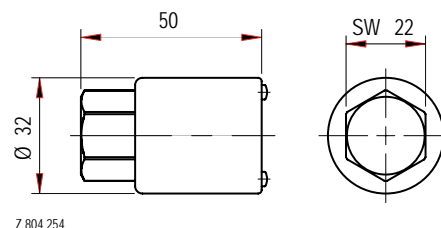

Z 804 254

Order no.	Size	Weight
804 254	AF22	0.08kg

During assembly pay attention to the torque, as per technical information.

Slide coupling

- Can be switched



Characteristics:

Pneumatic coupling element with slide valve for SPEEDY airtec.

Application:

Actuation of the fast closing clamps SPEEDY airtec.

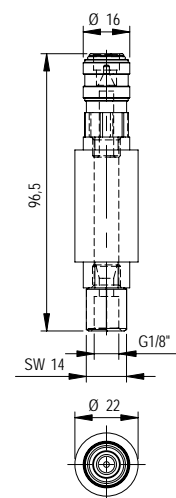

Z 5000 300

Order no.	Connection	Weight
5000 300	G1/8"	0.20kg

Coupling nipple



Characteristics:

Coupling nipple for SPEEDY airtec in conjunction with coupling art. no. 5000 300.

Application:

For the connection and actuation of the fast closing clamps SPEEDY airtec.

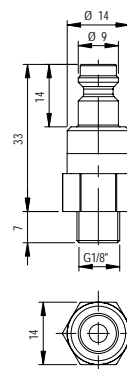

Z 5000 301

Order no.	Connection	Weight
5000 301	G1/8"	0.05kg

Only the original ...



...fits together!

**For this reason
our customers receive:**

- Manufacturer's guarantee
- Function guarantee
- Warranty protection
- Selection of fits







STARK zero point clamping systems



Consultation, planning, design, production, mounting, service – everything from a single source!

Cost savings in manufacturing are these days increasingly only possible during machine set-up and by shortening the process times. Your production will be significantly faster by using zero point clamping systems.

Key aspects such as focusing on bottlenecks (TOC), shortening of cycle times, batch sizes and inventory reduction, to name but a few advantages, are implemented quickly in manufacturing by using STARK zero point clamping systems.

Utilise the extensive experience and flexibility of specialists in zero point clamping technology to optimise your production.

The clamping system SPEEDY airtec is robust in use, thanks to its low height and variable spacing it is also very well suited to one-off parts as well as small and large production runs.

Due to the special retractable nipple contour and the matched radii, the bore is not damaged on insertion in the SPEEDY. No chips can be jammed in the cylindrical bore and due to the optimal application of force – the retractable nipples are fixed positively and highly accurately by spring action – bending or lifting is not possible and as a result high positioning accuracy is guaranteed.

Positioning, clamping, releasing –SPEEDY airtec integrates everything in one intelligent pneumatic zero point clamping system.

Stark Spannsysteme GmbH

Kommingerstraße 48

A6840 Götzis

Tel. +43 (0) 5523 64739-0

Fax +43 (0) 5523 64739-7

verkauf@stark-inc.com

www.stark-inc.com