

Work Supports

contact by spring force or air pressure,
single acting, max. operating pressure 500 bar



Application

Hydraulic work supports are used to provide a self-adjusting rest for the workpiece during the machining operations. They compensate the workpiece surface irregularities, also deflection and vibration under machining loads.

Installation

The universal block cylinder shape allows vertical and horizontal mounting, with oil feed via normal pipe connection or by manifold mounting direct to the fixture through drilled channels in the fixture body.

Function

Hydraulic locking is made together with hydraulic clamping of the workpiece, or independently. The support plunger is provided with female thread to enable the use of threaded pieces for height adjustment.

There are three variations of plunger actuation:

- 1. Spring advanced;** plunger extended in off-position
- 2. Air pressure advanced;** without spring return
- 3. Air pressure advanced;** with spring return

The pneumatically-actuated plunger allows precise setting of the plunger contact force by means of a pressure reducing valve. If a danger exists of sucking fluids through the pneumatic port, on the spring-advanced unit, a vent hose should be connected.

Accessory

Screw-in contact bolts
see data sheet G 3.800

Important notes!

Work supports are not suitable to compensate side loads.

Operating conditions, tolerances and other data see data sheet A 0.100.

It is absolutely necessary to follow the instructions for venting of the spring area on data sheet A 0.110.

192X-X01

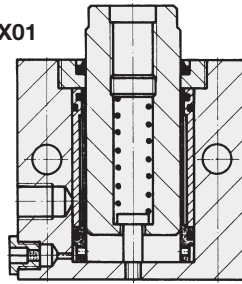

192X-X02

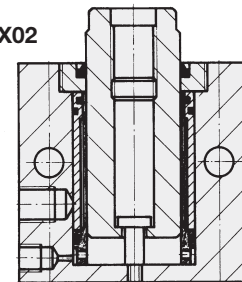

192X-X03

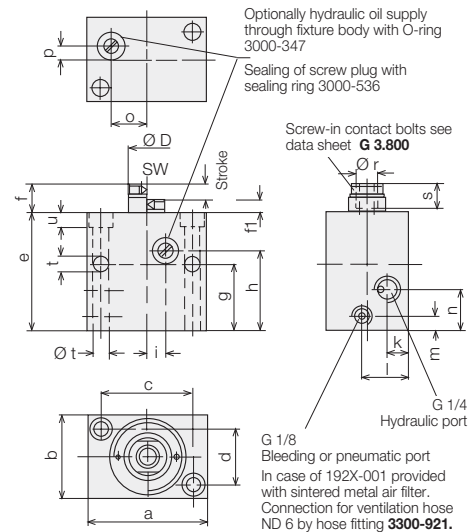
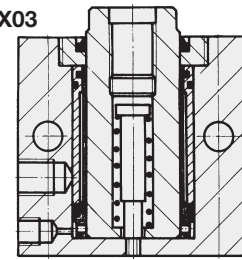

Admissible load F as function of the operating pressure p

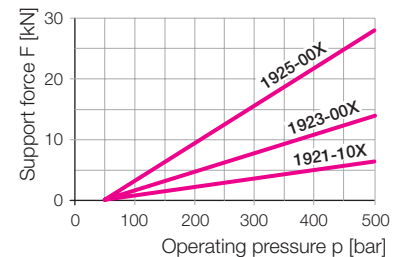

Plunger Ø D	[mm]	16	20	35
Stroke	[mm]	6	8	10
Support force at 500 bar	[kN]	7	12.5	28
Spring force min.	[N]	8	13.5	19.2
Spring force max.	[N]	10	17	24
Plunger contact force at 1 bar air pressure (deduct spring force if necessary)	[N]	20.1	31.4	96.2
Recom. min. oil pressure	[bar]	100	100	100
a	[mm]	60	65	85
b	[mm]	35	45	63
c	[mm]	40	50	63
d	[mm]	22	30	40
e	[mm]	56	64	79
f	[mm]	12	15	20
f1	[mm]	6	7	10
g	[mm]	26	36	39
h	[mm]	36	43	52
i	[mm]	7	10	12
k	[mm]	12.5	11.5	20.5
l	[mm]	17.5	25.5	39.5
m	[mm]	8.5	8	8
n	[mm]	38	22	25
o	[mm]	14.5	19	25
p	[mm]	5	7	11
Ø r	[mm]	M 10	M 12	M 16
s	[mm]	14	14	21
Ø t	[mm]	6.5	8.5	10.5
u	[mm]	6	8	10
SW	[mm]	13	17	27
Weight	[kg]	0.8	1.2	2.6

Part-no.	Extended by	Spring force	1921-101	1923-001	1925-001
		Air pressure	1921-102	1923-002	1925-002
		Air pressure with spring return	1921-103	1923-003	1925-003
Accessories		Screw plug G 1/4	3610-006	3610-006	3610-006
		O-ring 10 x 2	3000-347	3000-347	3000-347
		Spare seal ring	3000-536	3000-536	3000-536