



Unit 11 Sketchley Meadows  
Sketchley Meadows Industrial Estate  
Hinckley, Leicestershire LE10 3EN

Tel: 01455 611116

Fax: 01455 614282

Email: [info@achydraulics.co.uk](mailto:info@achydraulics.co.uk)



## MHI..MHD Series

TIE ROD CYLINDERS

ISO 6020

DIN 24554

# MHI/MHD

## How to order an MHI or MHD Cylinder

Each SWP series cylinder is assigned a model code.  
Use the example shown to develop your  
MHI or MHD cylinder requirement. Refer also to our  
Technical Information on pages 15 to 19.

SWP MODEL CODE		MHI	ME5	SR	63	300	NC	36	2	U	BSP	S
Cylinder Series	MHI for ISO6020-2 _____ MHD for DIN24554 _____											
Mounting Style	MS2 MS2K ME5 MP1 MP3 _____ ME6 MP5 MT1 MT2 _____ MT4 MX1 MX2 MX3 _____											
Configuration	Specify SR for Single rod _____ DR for Double rod _____											
Bore Size	Specify in millimetres _____											
Stroke Length	Specify in millimetres _____											
Cushion Details	NC No Cushions _____ CR Cushioned at rod _____ CB Cushioned at blind end _____ CC Cushioned both _____ Standard cushion position is 3 _____											
Rod Size	Specify in millimetres _____											
Rod Style	See page 19 for available rod styles Specify S followed by details _____ where a special rod style is required _____											
Seals	U Standard nitrile _____ L Low friction _____ V Viton _____											
Ports	Specify Port Type BSP NPT SAE Metric _____ Standard port position is 1 _____											
Special features	Specify S followed by a description _____											
For double rod cylinders specify rod size and rod end style for both piston rods												

## Mounting Information

### Side Mounting

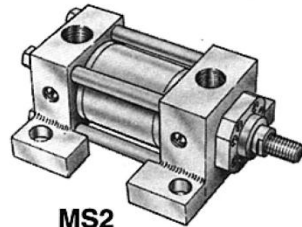

**MS2**  
Side Lugs

### Double Rod Cylinders

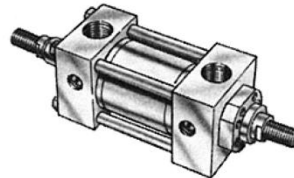

**DR**

### End Mountings

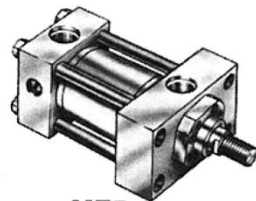

**ME5**  
Head Rectangular

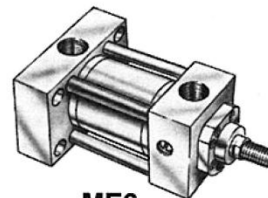

**ME6**  
Cap Rectangular

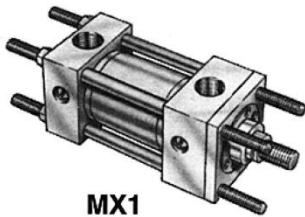

**MX1**  
Both Ends Tie Rods  
Extended

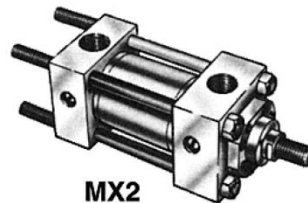

**MX2**  
Cap Tie Rods  
Extended

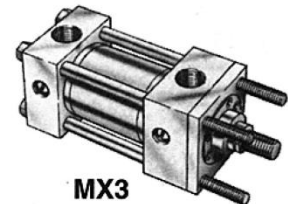

**MX3**  
Head Tie Rods  
Extended

### Pivot Mountings

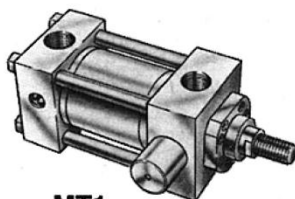

**MT1**  
Head Integral Trunnion

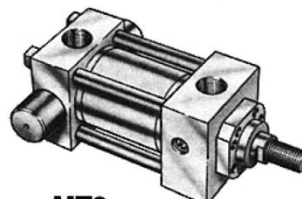

**MT2**  
Cap Integral Trunnion

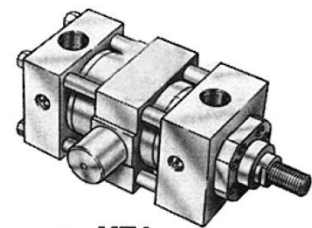

**MT4**  
Intermediate Fixed  
Trunnion

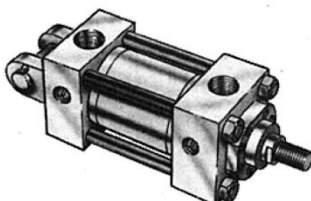

**MPI**  
Cap Fixed Clevis

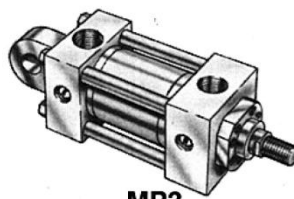

**MP3**  
Cap Fixed Eye

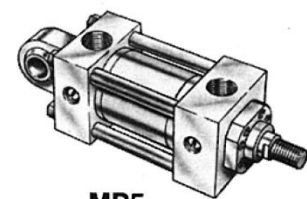

**MP5**  
Cap Fixed Eye  
with Spherical Bearing

# MHI

## Flange and Side Lugs Mountings

### MHI-ME5 Head Rectangular

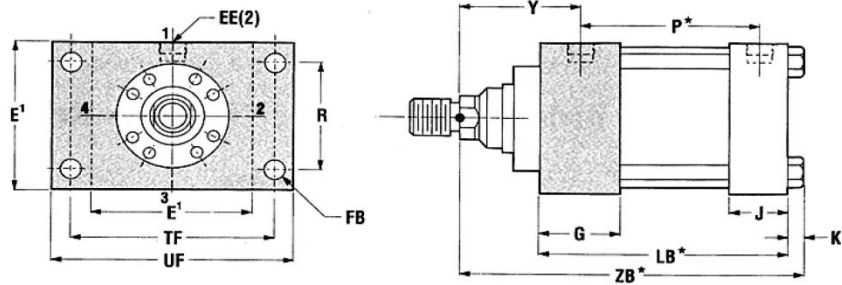

### MHI-ME6 Cap Rectangular

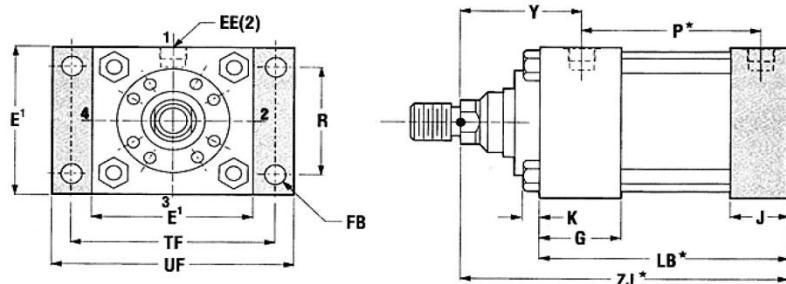

### MHI-MS2 Side Lugs

Specify MS2 K  
when keyplate is required.

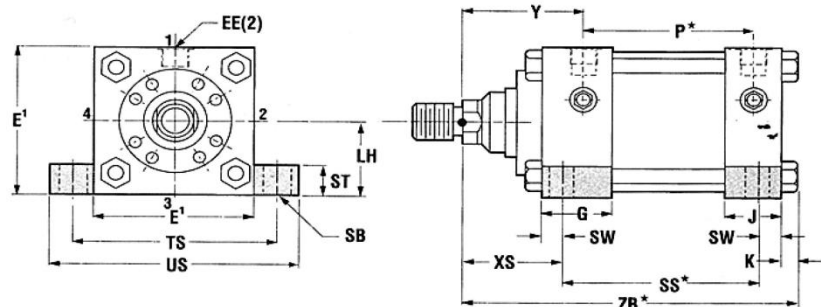

## Mounting Dimensions - Also page 19 for rod end dimensions

Bore Dia.	E	EE BSP/G Inches	FB	G	J	K	LB*	LH	P*	R	SB	SS*	ST	SW	TF	TS	UF	US	XS	Y	ZB*	ZJ*	
25	40 <sup>1</sup>	1/4	5,5	40	25	4	89	19	+0,000 -0,084	53	27	6,6	73	8,5	8	51	54	65	72	33	50	118	114
32	45 <sup>1</sup>	1/4	6,6	40	25	5	93	22	+0,000 -0,084	56	33	9	73	12,5	10	58	63	70	84	45	60	133	128
40	63	3/8	11	45	38	6,5	118	31	+0,000 -0,100	73	41	11	98	12,5	10	87	83	110	103	45	62	159,5	153
50	75	1/2	14	45	38	10	118	37	+0,000 -0,100	74	52	14	92	19	13	105	102	130	127	54	67	169	159
63	90	1/2	14	45	38	10	120	44	+0,000 -0,100	80	65	18	86	26	17	117	124	145	161	65	71	178	168
80	115	3/4	18	50	45	13	139	57	+0,000 -0,120	93	83	18	105	26	17	149	149	180	186	68	77	203	190
100	130	3/4	18	50	45	13	146	63	+0,000 -0,120	101	97	26	102	32	22	162	172	200	216	79	82	216	203
125	165	1	22	58	58	18	175	82	+0,000 -0,140	117	126	26	131	32	22	208	210	250	254	79	86	250	232
160	205	1	26	58	58	22	188	101	+0,000 -0,140	130	155	33	130	38	29	253	260	300	318	86	86	267	245
200	245	1 1/4	33	76	76	24	242	122	+0,000 -0,160	165	190	39	172	44	35	300	311	360	381	92	98	323	299

All dimensions in millimetres unless otherwise stated.

\*Add stroke to all starred dimensions.

<sup>1</sup>Head depth increased by 5mm to accommodate port on 25mm and 32mm bore cylinders. See page 19.

## Clevis Mountings

### MHI - MPI Cap Fixed Clevis

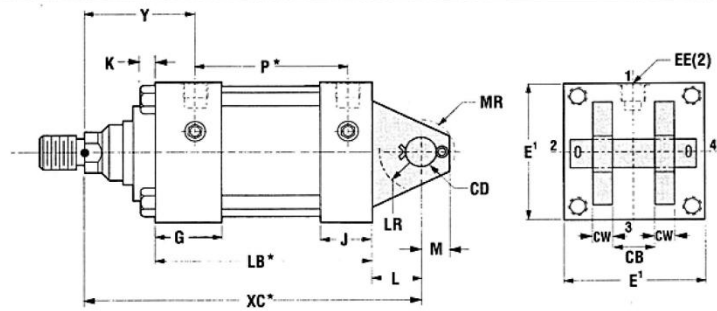

### MHI-MP3 Cap Fixed Eye

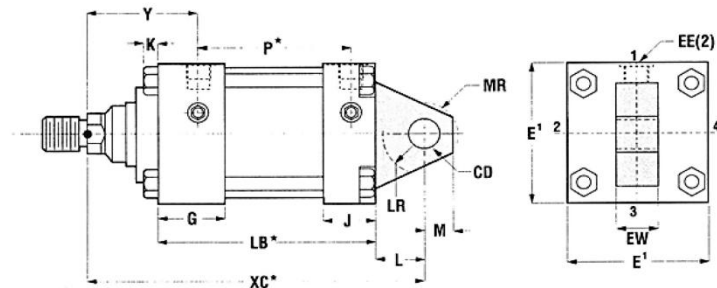

### MHI-MP5 Cap Spherical Bearing

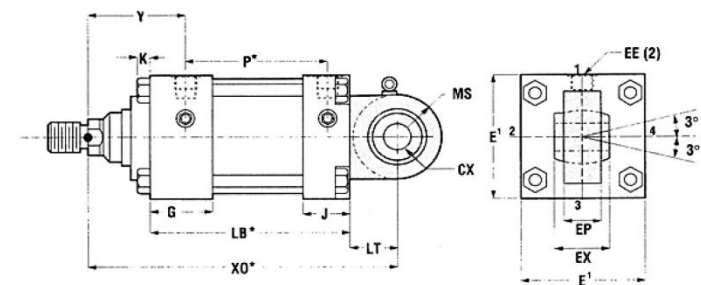

## Mounting Dimensions - Also page 19 for rod end dimensions

Bore Dia.	CB	CD	Hole Tol.	Pin Tol.	CW	CX	E	EE BSPG inches	EP	EW	EX	G	J	K	L	LB*	LR	LT	M	MR	MS	P*	XC*	X0*	Y	
25	12	10	+0.036 -0.000	-0.016 -0.043	6	12	+0.000 -0.008	40 <sup>1</sup>	1/4	8	12	10	40	25	4	13	89	12	16	10	12	20	53	127	130	50
32	16	12	+0.043 -0.000	-0.016 -0.043	8	16	+0.000 -0.008	45 <sup>1</sup>	1/4	11	16	14	40	25	5	19	93	17	20	12	17	22,5	56	147	148	60
40	20	14	+0.043 -0.000	-0.016 -0.043	10	20	+0.000 -0.012	63	3/8	13	20	16	45	38	6,5	19	118	17	25	14	17	29	73	172	178	62
50	30	20	+0.052 -0.000	-0.020 -0.053	15	25	+0.000 -0.012	75	1/2	17	30	20	45	38	10	32	118	29	31	20	29	33	74	191	190	67
63	30	20	+0.052 -0.000	-0.020 -0.053	15	30	+0.000 -0.012	90	1/2	19	30	22	45	38	10	32	120	29	38	20	29	40	80	200	206	71
80	40	28	+0.052 -0.000	-0.020 -0.053	20	40	+0.000 -0.012	115	3/4	23	40	28	50	45	13	39	139	34	48	28	34	50	93	229	238	77
100	50	36	+0.062 -0.000	-0.025 -0.064	25	50	+0.000 -0.012	130	3/4	30	50	35	50	45	13	54	146	50	58	36	50	62	101	257	261	82
125	60	45	+0.062 -0.000	-0.025 -0.064	30	60	+0.000 -0.015	165	1	38	60	44	58	58	18	57	175	53	72	45	53	80	117	289	304	86
160	70	56	+0.074 -0.000	-0.030 -0.076	35	80	+0.000 -0.015	205	1	47	70	55	58	58	22	63	188	59	92	59	59	100	130	308	337	86
200	80	70	+0.074 -0.000	-0.030 -0.076	40	100	+0.000 -0.020	245	1 1/4	57	80	70	76	76	24	82	242	78	116	70	78	120	165	381	415	98

All dimensions in millimetres unless otherwise stated.

\*Add stroke to all starred dimensions.

<sup>1</sup>Head depth increased by 5mm to accommodate port on 25mm and 32mm bore cylinders. See page 19.

# MHI

## Trunnion Mountings

### MHI - MT1 Head Trunnion

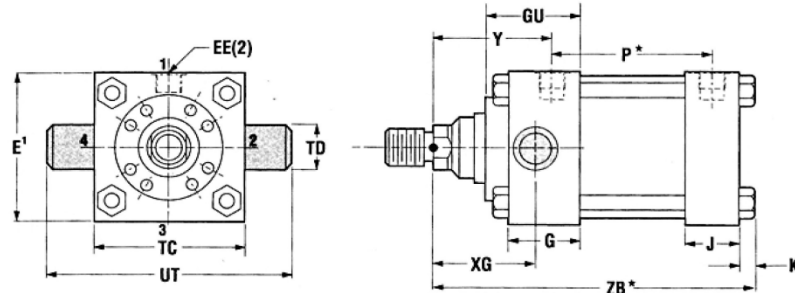

NOTE: On 100-200mm bore cylinders, GU dimension replaces G dimension, and circular retainer is recessed into the head.

### MHI-MT2 Cap Trunnion

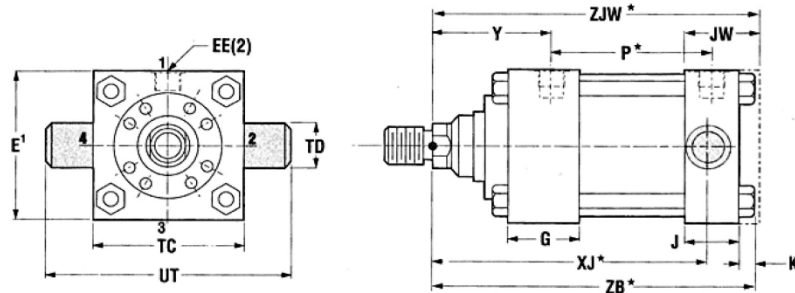

NOTE: On 80-200mm bore cylinders, JW dimension replaces J, ZJW replaces ZB, and cylinder tie rods are threaded directly into the cap.

### MHI-MT4 Intermediate Fixed Trunnion

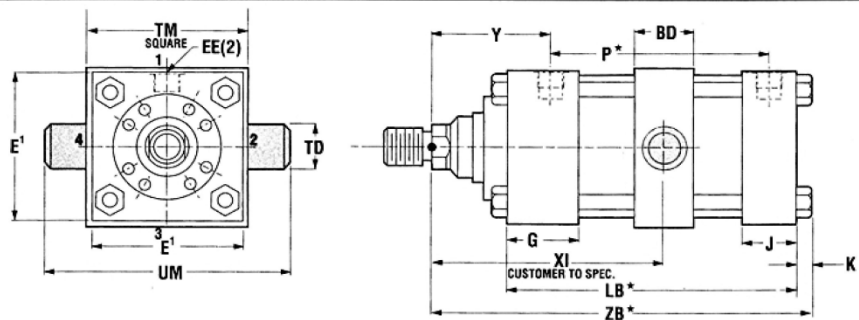

## Mounting Dimensions - Also page 19 for rod end dimensions

Bore Dia.	BD	E	EE BSP/G Inches	G	GU	J	JW	K	LB*	P*	TC	TD	TM	UM	UT	XG	XJ*	Y	ZB*	ZJW*	
25	20	40 <sup>1</sup>	1/4	40	-	25	-	4	89	53	38	12	-0.016 -0.043	48	68	58	44	101	50	118	-
32	25	45 <sup>1</sup>	1/4	40	-	25	-	5	93	56	44	16	-0.016 -0.043	55	79	68	54	115	60	133	-
40	30	63	3/8	45	-	38	-	6,5	118	73	63	20	-0.020 -0.053	76	108	95	57	134	62	159,5	-
50	40	75	1/2	45	-	38	-	10	118	74	76	25	-0.020 -0.053	89	129	116	64	140	67	169	-
63	40	90	1/2	45	-	38	-	10	120	80	89	32	-0.025 -0.064	100	150	139	70	149	71	178	-
80	50	115	3/4	50	-	45	50	13	139	93	114	40	-0.025 -0.064	127	191	178	76	168	77	203	195
100	60	130	3/4	50	72	45	58	13	146	101	127	50	-0.025 -0.064	140	220	207	71	187	82	216	216
125	73	165	1	58	80	58	72	18	175	117	165	63	-0.030 -0.076	178	278	265	75	209	86	250	246
160	90	205	1	58	88	58	88	22	188	130	203	80	-0.030 -0.076	215	341	329	75	230	86	267	275
200	110	245	1 1/4	76	108	76	108	24	242	165	241	100	-0.036 -0.090	279	439	401	85	276	98	323	331

All dimensions in millimetres unless otherwise stated.

\*Add stroke to all starred dimensions.

<sup>1</sup>Head depth increased by 5mm to accommodate port on 25mm and 32mm bore cylinders. See page 19.

# MHI

## Extended Tie Rod Mountings

### MHI - MX3 Head End Tie Rods Extended

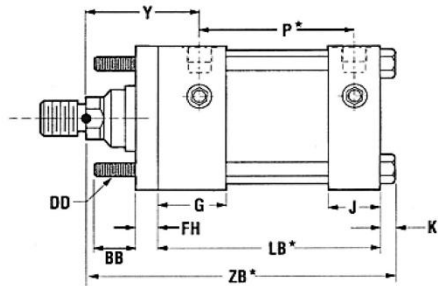
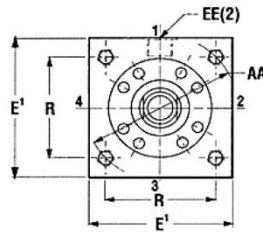

### MHI - MX2 Cap End Tie Rods Extended

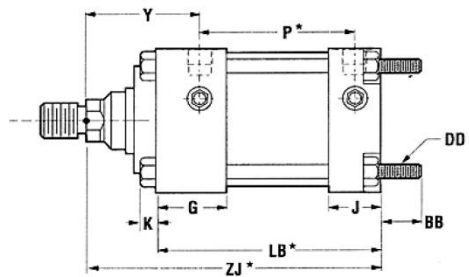
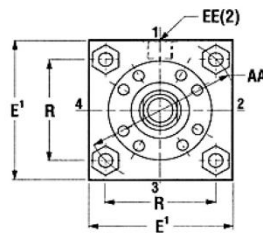

### MHI - MX1 Tie Rods Extended Both Ends

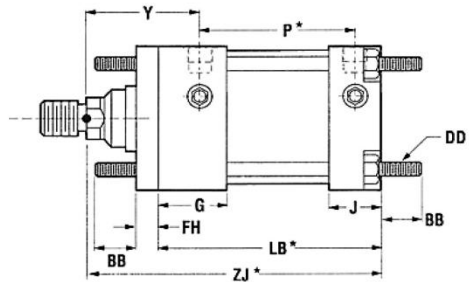
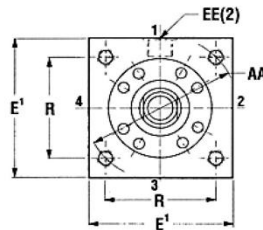

### Mounting Dimensions - Also page 19 for rod end dimensions

Bore Dia.	AA	BB	DD	E	EE BSPG Inches	FH	G	J	K	LB*	P*	R	Y	ZB*	ZJ*
25	40	19	M5 x 0,8	40 <sup>1</sup>	1/4	10	40	25	4	89	53	28,3	50	118	114
32	47	24	M6 x 1	45 <sup>1</sup>	1/4	10	40	25	5	93	56	33,2	60	133	128
40	59	35	M8 x 1	63	3/8	10	45	38	6,5	118	73	41,7	62	159,5	153
50	74	46	M12 x 1,25	75	1/2	16	45	38	10	118	74	52,3	67	169	159
63	91	46	M12 x 1,25	90	1/2	16	45	38	10	120	80	64,3	71	178	168
80	117	59	M16 x 1,5	115	3/4	20	50	45	13	139	93	82,7	77	203	190
100	137	59	M16 x 1,5	130	3/4	22	50	45	13	146	101	96,9	82	216	203
125	178	81	M22 x 1,5	165	1	22	58	58	18	175	117	125,9	86	250	232
160	219	92	M27 x 2	205	1	25	58	58	22	188	130	154,9	86	267	245
200	269	115	M30 x 2	245	1 1/4	25	76	76	24	242	165	190,2	98	323	299

All dimensions in millimetres unless otherwise stated.

\*Add stroke to all starred dimensions.

<sup>1</sup>Head depth increased by 5mm to accommodate port on 25mm and 32mm bore cylinders. See page 19.

## Double Rod Cylinders

### Double Rod Cylinder

Available in all mounts except MPI, MP3, MP5 & MT2

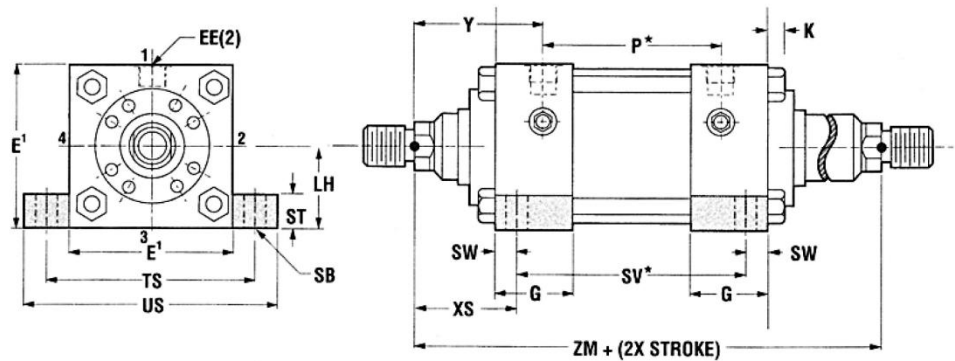

Example shown: MHI-MS2-DR - Side Lugs - Double Lugs

## Double Rod Dimensions

Bore Dia.	Road Dia.	LD*	P*	SV*	ZM**
25	12	104	53	88	154
	18				
32	14	108	56	88	178
	22				
40	18	125	73	105	195
	28				
50	22	125	74	99	207
	36				
63	28	127	80	93	223
	45				
80	36	144	93	110	246
	56				
100	45	151	101	107	265
	70				
125	56	175	117	131	289
	90				
160	70	188	130	130	302
	110				
200	90	242	160	172	356
	140				

All dimensions in millimetres unless otherwise stated.

\*Add stroke to all starred dimensions.

\*\*Add 2x stroke to all these dimensions.



# MHI/MHD

## Mounting Accessories

### Rod End Accessory Combinations

Thread KK	Plain Rod Eye	Clevis Bracket	Plain Pivot Pin
M10 x 1,25	MHI-9310	MHI-133-25	MHI-9025-3
M12 x 1,25	MHI-9312	MHI-133-32	MHI-9032-3
M14 x 1,5	MHI-9314	MHI-133-40	MHI-9040-3
M16 x 1,5	MHI-9316	MHI-133-50	MHI-9063-3
M20 x 1,5	MHI-9320	MHI-133-63	MHI-9063-3
M27 x 2	MHI-9327	MHI-133-80	MHI-9080-3
M33 x 2	MHI-9333	MHI-133-100	MHI-90100-3
M42 x 2	MHI-9342	MHI-133-125	MHI-90125-3
M48 x 2	MHI-9348	MHI-133-160	MHI-90160-3
M64 x 3	MHI-9364	MHI-133-200	MHI-90200-3

### Cap End Mounting Clevis Bracket for MP3 Mount

Bore Diameter (mm)	Eye Bracket
25	MHI-133-25
32	MHI-133-32
40	MHI-133-40
50	MHI-133-50
63	MHI-133-63
80	MHI-133-80
100	MHI-133-100
125	MHI-133-125
160	MHI-133-160
200	MHI-133-200

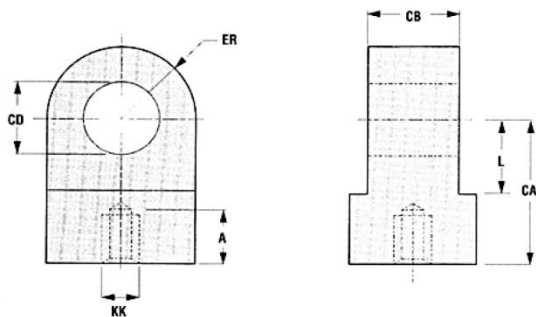

**Plain Rod Eye**

Part No.	A <sub>min</sub>	CA	CB	CD	ER <sub>max</sub>	KK	L <sub>min</sub>
MHI-9310	14	32	12	10	12	M10 x 1,25	13
MHI-9312	16	36	16	12	17	M12 x 1,25	19
MHI-9314	18	38	20	14	17	M14 x 1,5	19
MHI-9316	22	54	30	20	29	M16 x 1,5	32
MHI-9320	28	60	30	20	29	M20 x 1,5	32
MHI-9327	36	75	40	28	34	M27 X 2	39
MHI-9333	45	99	50	36	50	M33 x 2	54
MHI-9342	56	113	60	45	53	M42 x 2	57
MHI-9348	63	126	70	56	59	M48 X 2	63
MHI-9364	85	168	80	70	78	M64 x 3	83

All dimensions in millimetres unless otherwise stated.

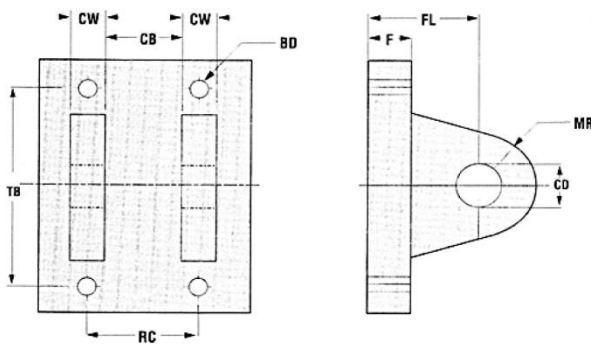

**Clevis Bracket**

Part No.	BD	CB	CD	CW <sub>max</sub>	F <sub>max</sub>	FL	MR <sub>max</sub>	RC	TB
MHI-133-25	5,5	12	10	7	10	23	12	18	47
MHI-133-32	6,6	16	12	9	10	29	17	24	57
MHI-133-40	9	20	14	11	10	29	17	30	68
MHI-133-50	13,5	30	20	16	16	48	29	45	102
MHI-133-63	13,5	30	20	16	16	48	29	45	102
MHI-133-80	17,5	40	28	21,5	20	59	34	60	135
MHI-133-100	17,5	50	36	26,5	25	79	50	75	167
MHI-133-125	24	60	45	31,5	30	87	53	90	183
MHI-133-160	30	70	56	36,5	40	103	59	105	242
MHI-133-200	33	80	70	41,5	50	132	78	120	300

All dimensions in millimetres unless otherwise stated.

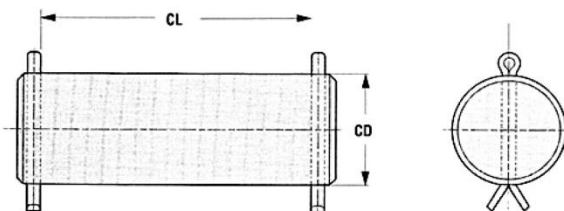

**Plain Pivot Pin**

Part No.	CD	CL <sub>min</sub>
MHI-9025-3	10	29
MHI-9032-3	12	37
MHI-9040-3	14	45
MHI-9063-3	20	66
MHI-9080-3	28	87
MHI-90100-3	36	107
MHI-90125-3	45	129
MHI-90160-3	56	149
MHI-90200-3	70	169

All dimensions in millimetres unless otherwise stated.  
NOTE CERTAIN PIVOT PINS ARE SUPPLIED WITH CIRCLIPS.

# MHI/MHD

## Mounting Accessories

Selecting Accessories: Rod end accessories are selected by the corresponding rod end threads. Cap end accessories are selected by cylinder bore size. Reference the following tables:

### Rod End Accessory Combinations

Thread KK	Plain Rod Clevis	Eye Bracket	Plain Pivot Pin
M10 x 1,25	MHI-134-10	MHI-8925	MHI-9025-3
M12 x 1,25	MHI-134-12	MHI-8932	MHI-9032-3
M14 x 1,5	MHI-134-14	MHI-8940	MHI-9040-3
M16 x 1,5	MHI-134-16	MHI-8950	MHI-9063-3
M20 x 1,5	MHI-134-20	MHI-8963	MHI-9063-3
M27 x 2	MHI-134-27	MHI-8980	MHI-9080-3
M33 x 2	MHI-134-33	MHI-89100	MHI-90100-3
M42 x 2	MHI-134-42	MHI-89125	MHI-90125-3
M48 x 2	MHI-134-48	MHI-89160	MHI-90160-3
M64 x 3	MHI-134-64	MHI-89200	MHI-90200-3

### Cap End Mounting Eye Bracket for MP1 Mount

Bore Diameter (mm)	Eye Bracket
25	MHI-8925
32	MHI-8932
40	MHI-8940
50	MHI-8950
63	MHI-8963
80	MHI-8980
100	MHI-89100
125	MHI-89125
160	MHI-89160
200	MHI-89200

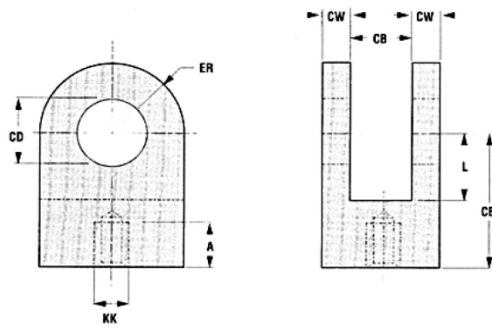

**Plain Rod Clevis**

Part No.	A <sub>min</sub>	CD	CB <sub>max</sub>	CE	CW	ER <sub>max</sub>	KK	L <sub>min</sub>
MHI-134-10	14	10	12	32	7	12	M10 x 1,25	13
MHI-134-12	16	12	16	36	9	17	M12 x 1,25	19
MHI-134-14	18	14	20	38	11	17	M14 x 1,5	19
MHI-134-16	22	20	30	54	16	29	M16 x 1,5	32
MHI-134-20	28	20	30	60	16	29	M20 x 1,5	32
MHI-134-27	36	28	40	75	21,5	34	M27 X 2	39
MHI-134-33	45	36	50	99	26,5	50	M33 x 2	54
MHI-134-42	56	45	60	113	31,5	53	M42 x 2	57
MHI-134-48	63	56	70	126	36,5	59	M48 X 2	63
MHI-134-64	85	70	80	168	41,5	78	M64 x 3	83

All dimensions in millimetres unless otherwise stated.

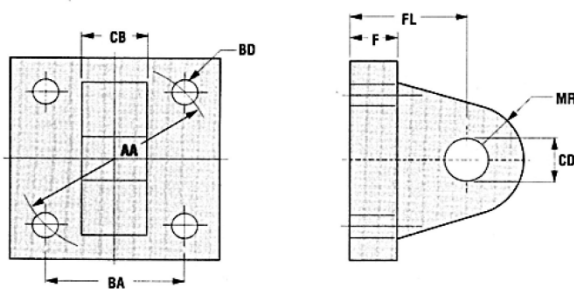

**Eye Bracket**

Part No.	AA	BA	BD	CB	CD	F <sub>max</sub>	FL	MR <sub>max</sub>
MHI-8925	40	28,3	5,5	12	10	10	23	12
MHI-8932	47	33,2	6,6	16	12	10	29	17
MHI-8940	59	41,7	9	20	14	10	29	17
MHI-8950	74	52,3	13,5	30	20	16	48	29
MHI-8963	91	64,3	13,5	30	20	16	48	29
MHI-8980	117	82,7	17,5	40	28	20	59	34
MHI-89100	137	96,9	17,5	50	36	25	79	50
MHI-89125	178	125,9	24	60	45	30	87	53
MHI-89160	219	154,9	30	70	56	40	103	59
MHI-89200	269	190,2	33	80	70	50	132	78

All dimensions in millimetres unless otherwise stated.

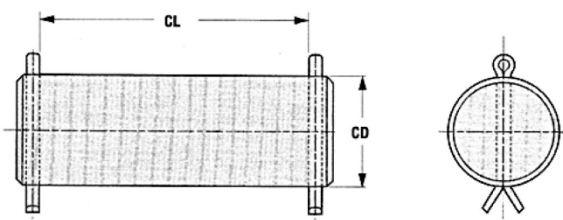

**Plain Pivot Pin**

Part No.	CD	CL <sub>min</sub>
MHI-9025-3	10	29
MHI-9032-3	12	37
MHI-9040-3	14	45
MHI-9063-3	20	66
MHI-9080-3	28	87
MHI-90100-3	36	107
MHI-90125-3	45	129
MHI-90160-3	56	149
MHI-90200-3	70	169

All dimensions in millimetres unless otherwise stated.

## Mounting Accessories

### Rod End Accessory Combinations

Thread KK	Rod Eye with Spherical Bearing	Clevis Bracket for Spherical Bearing and Pivot Pin
M10 x 1,25	MHI-S-9310	MHI-S-133-25
M12 X 1,25	MHI-S-9312	MHI-S-133-32
M14 x 1,5	MHI-S-9314	MHI-S-133-40
M16 x 1,5	MHI-S-9316	MHI-S-133-50
M20 x 1,5	MHI-S-9320	MHI-S-133-63
M27 x 2	MHI-S-9327	MHI-S-133-80
M33 x 2	MHI-S-9333	MHI-S-133-100
M42 x 2	MHI-S-9342	MHI-S-133-125
M48 x 2	MHI-S-9348	MHI-S-133-160
M64 x 3	MHI-S-9634	MHI-S-133-200

### Cap End Mounting-Clevis Bracket for Spherical Bearing and Pivot Pin for MP5 Mount

Bore Diameter (mm)	Clevis Bracket for Spherical Bearing and Pivot Pin
25	MHI-S-133-25
32	MHI-S-133-32
40	MHI-S-133-40
50	MHI-S-133-50
63	MHI-S-133-63
80	MHI-S-133-80
100	MHI-S-133-100
125	MHI-S-133-125
160	MHI-S-133-160
200	MHI-S-133-200

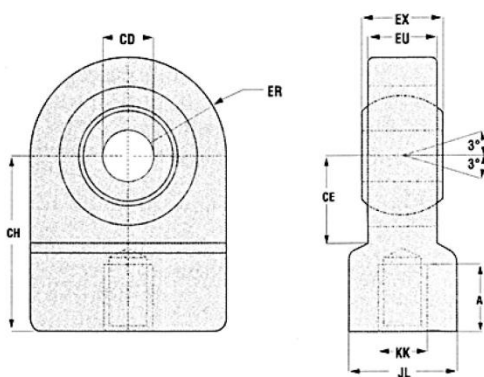

**Rod Eye with Spherical Bearing**

Part No.	A <sub>min</sub>	CD	CE <sub>min</sub>	CH	ER <sub>max</sub>	EU	EX	JL <sub>max</sub>	KK
MHI-S-9310	15	12 <sup>+0,000 -0,008</sup>	16	42	20	8	10 <sup>+0,000 -0,120</sup>	17	M10 x 1,25
MHI-S-9312	17	16 <sup>+0,000 -0,008</sup>	20	48	22,5	11	14 <sup>+0,000 -0,120</sup>	21	M12 x 1,25
MHI-S-9314	19	20 <sup>+0,000 -0,012</sup>	25	58	27,5	13	16 <sup>+0,000 -0,120</sup>	25	M14 x 1,5
MHI-S-9316	23	25 <sup>+0,000 -0,012</sup>	30	68	32,5	17	20 <sup>+0,000 -0,120</sup>	30	M16 x 1,5
MHI-S-9320	29	30 <sup>+0,000 -0,012</sup>	35	85	40	19	22 <sup>+0,000 -0,120</sup>	36	M20 x 1,5
MHI-S-9327	37	40 <sup>+0,000 -0,012</sup>	45	105	50	23	28 <sup>+0,000 -0,120</sup>	45	M27 x 2
MHI-S-9333	46	50 <sup>+0,000 -0,012</sup>	58	130	62,5	30	35 <sup>+0,000 -0,120</sup>	55	M33 x 2
MHI-S-9342	57	60 <sup>+0,000 -0,015</sup>	68	150	80	38	44 <sup>+0,000 -0,150</sup>	68	M42 x 2
MHI-S-9348	64	80 <sup>+0,000 -0,015</sup>	92	185	102,5	47	55 <sup>+0,000 -0,200</sup>	90	M48 x 2
MHI-S-9634	86	100 <sup>+0,000 -0,020</sup>	116	240	120	57	70 <sup>+0,000 -0,200</sup>	110	M64 x 3

All dimensions in millimetres unless otherwise stated.

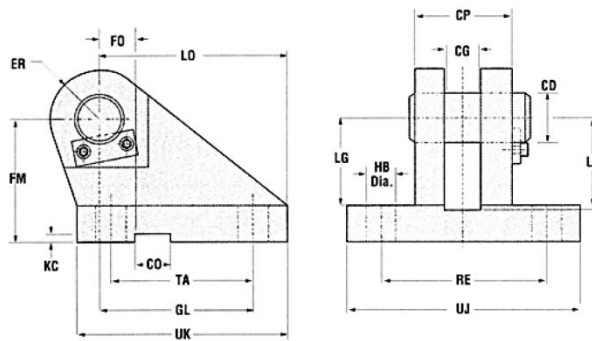

**Clevis Bracket for Spherical Bearing and Pivot Pin**

Part No.	CD Pin Dia.	CG <sup>+0,3</sup> <sub>-0,1</sub>	CO	CP	ER <sub>max</sub>	FM	FO	GL	HB	KC <sup>+0,3</sup> <sub>-0,0</sub>	LG	LJ	LO	RE	TA	UJ	UK	
MHI-S-133-25	12	<sup>+0,019</sup> <sub>+0,001</sub>	10	10 <sup>+0,000 -0,058</sup>	30	12	40	16	46	9	3,3	28	29	56	55	40	75	60
MHI-S-133-32	16	<sup>+0,019</sup> <sub>+0,001</sub>	14	16 <sup>+0,000 -0,070</sup>	40	16	50	18	61	11	4,3	37	38	74	70	55	95	80
MHI-S-133-40	20	<sup>+0,023</sup> <sub>+0,002</sub>	16	16 <sup>+0,000 -0,070</sup>	50	20	55	20	64	14	4,3	39	40	80	85	58	120	90
MHI-S-133-50	25	<sup>+0,023</sup> <sub>+0,002</sub>	20	25 <sup>+0,000 -0,084</sup>	60	25	65	22	78	16	5,4	48	49	98	100	70	140	110
MHI-S-133-63	30	<sup>+0,023</sup> <sub>+0,002</sub>	22	25 <sup>+0,000 -0,084</sup>	70	30	85	24	97	18	5,4	62	63	120	115	90	160	135
MHI-S-133-80	40	<sup>+0,027</sup> <sub>+0,002</sub>	28	36 <sup>+0,000 -0,100</sup>	80	40	100	24	123	22	8,4	72	73	148	135	120	190	170
MHI-S-133-100	50	<sup>+0,027</sup> <sub>+0,002</sub>	35	36 <sup>+0,000 -0,100</sup>	100	50	125	35	155	30	8,4	90	92	190	170	145	240	215
MHI-S-133-125	60	<sup>+0,032</sup> <sub>+0,002</sub>	44	50 <sup>+0,000 -0,100</sup>	120	60	150	35	187	39	11,4	108	110	225	200	185	270	260
MHI-S-133-160	80	<sup>+0,032</sup> <sub>+0,002</sub>	55	50 <sup>+0,000 -0,100</sup>	160	80	190	35	255	45	11,4	140	142	295	240	260	320	340
MHI-S-133-200	100	<sup>+0,038</sup> <sub>+0,003</sub>	70	63 <sup>+0,000 -0,120</sup>	200	100	210	35	285	48	12,4	150	152	335	300	300	400	400

All dimensions in millimetres unless otherwise stated.

# Flange and Side Lugs Mountings

## ME5 Head Rectangular

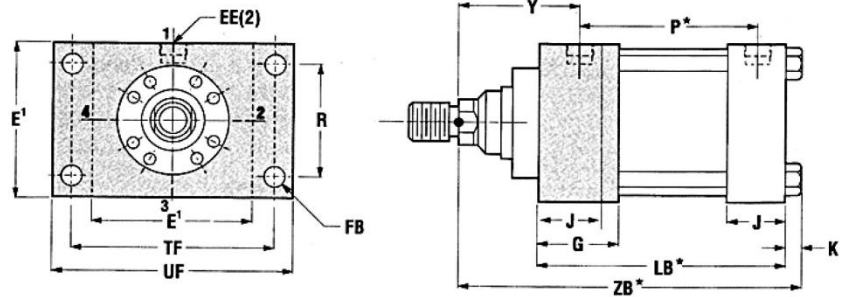

## ME6 Cap Rectangular

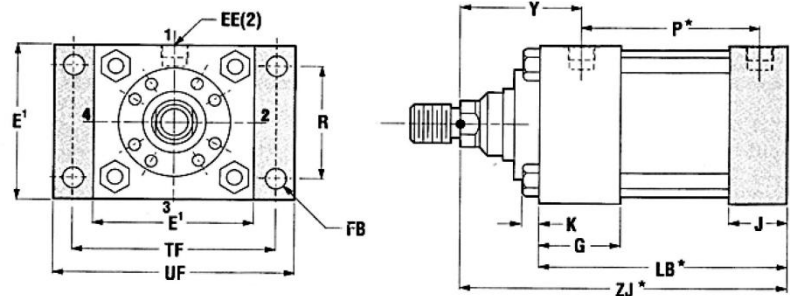

## MS2 Side Lugs

Specify MS2 K when keyplate is required.

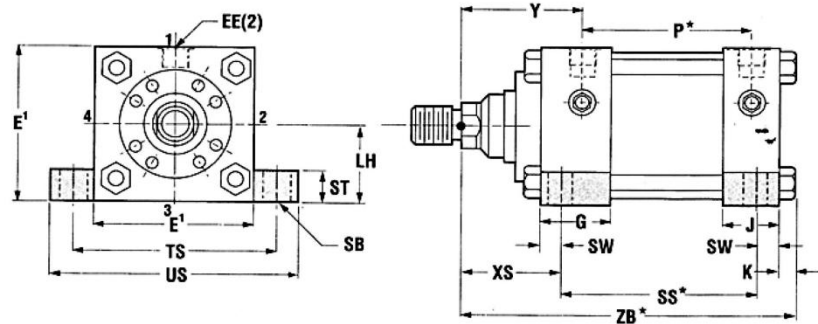

## Mounting Dimensions - Also page 19 for rod end dimensions

Bore Dia.	E	EE BSP/G Inches	FB	G	J	K	LB*	LH	P*	R	SB	SS*	ST	SW	TF	TS	UF	US	XS	Y	ZB*	ZJ*	
25	40 <sup>1</sup>	1/4	5,5	40	25	4	89	19	+0,000 -0,084	53	27	6,6	73	8,5	8	51	54	65	72	33	50	118	114
32	45 <sup>1</sup>	1/4	6,6	40	25	5	93	22	+0,000 -0,084	56	33	9	73	12,5	10	58	63	70	84	45	60	133	128
40	63	3/8	11	45	38	6,5	118	31	+0,000 -0,100	73	41	11	98	12,5	10	87	83	110	103	45	62	159,5	153
50	75	1/2	14	45	38	10	118	37	+0,000 -0,100	74	52	14	92	19	13	105	102	130	127	54	67	169	159
63	90	1/2	14	45	38	10	120	44	+0,000 -0,100	80	65	18	86	26	17	117	124	145	161	65	71	178	168
80	115	3/4	18	50	45	13	139	57	+0,000 -0,120	93	83	18	105	26	17	149	149	180	186	68	77	203	190
100	130	3/4	18	50	45	13	146	63	+0,000 -0,120	101	97	26	102	32	22	162	172	200	216	79	82	216	203
125	165	1	22	58	58	18	175	82	+0,000 -0,140	117	126	26	131	32	22	208	210	250	254	79	86	250	232
160	205	1	26	58	58	22	188	101	+0,000 -0,140	130	155	33	130	38	29	253	260	300	318	86	86	267	245
200	245	1 1/4	33	76	76	24	242	122	+0,000 -0,160	165	190	39	172	44	35	300	311	360	381	92	98	323	299

All dimensions in millimetres unless otherwise stated.

\*Add stroke to all starred dimensions.

<sup>1</sup>Head depth increased by 5mm to accommodate port on 25mm and 32mm bore cylinders. See page 19.

## Pivot Mountings

### MP5 Cap Spherical Bearing

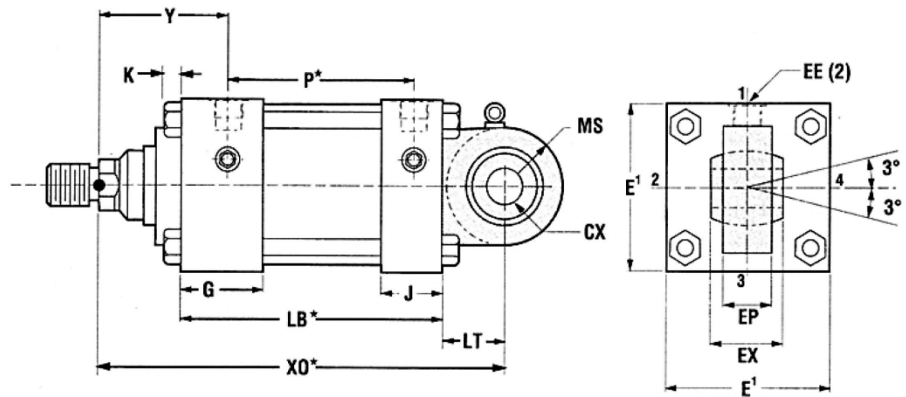

### MT4 Intermediate Fixed Trunnion

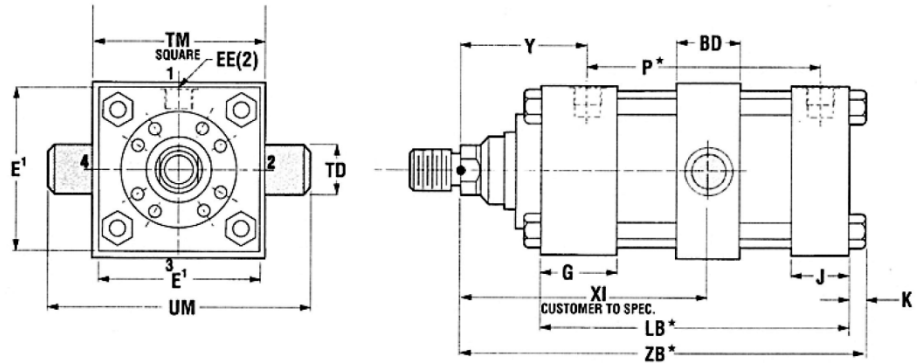

### Mounting Dimensions - Also page 19 for rod end dimensions

Bore Dia.	BD	CX	E	EE BSP/G Inches	EP	EX	G	J	K	LB*	LT	MS	P*	TD	TM	UM	X0*	Y	ZB*		
25	20	12	<sup>+0,000</sup> <sub>-0,008</sub>	40 <sup>1</sup>	1/4	8	10	40	25	4	89	16	20	53	12	<sup>-0,016</sup> <sub>-0,043</sub>	48	68	130	50	118
32	25	16	<sup>+0,000</sup> <sub>-0,008</sub>	45 <sup>1</sup>	1/4	11	14	40	25	5	93	20	22,5	56	16	<sup>-0,016</sup> <sub>-0,043</sub>	55	79	148	60	133
40	30	20	<sup>+0,000</sup> <sub>-0,012</sub>	63	3/8	13	16	45	38	6,5	118	25	29	73	20	<sup>-0,020</sup> <sub>-0,053</sub>	76	108	178	62	159,5
50	40	25	<sup>+0,000</sup> <sub>-0,012</sub>	75	1/2	17	20	45	38	10	118	31	33	74	25	<sup>-0,020</sup> <sub>-0,053</sub>	89	129	190	67	169
63	40	30	<sup>+0,000</sup> <sub>-0,012</sub>	90	1/2	19	22	45	38	10	120	38	40	80	32	<sup>-0,025</sup> <sub>-0,064</sub>	100	150	206	71	178
80	50	40	<sup>+0,000</sup> <sub>-0,012</sub>	115	3/4	23	28	50	45	13	139	48	50	93	40	<sup>-0,025</sup> <sub>-0,064</sub>	127	191	238	77	203
100	60	50	<sup>+0,000</sup> <sub>-0,012</sub>	130	3/4	30	35	50	45	13	146	58	62	101	50	<sup>-0,025</sup> <sub>-0,064</sub>	140	220	261	82	216
125	73	60	<sup>+0,000</sup> <sub>-0,015</sub>	165	1	38	44	58	58	18	175	72	80	117	63	<sup>-0,030</sup> <sub>-0,076</sub>	178	278	304	86	250
160	90	80	<sup>+0,000</sup> <sub>-0,015</sub>	205	1	47	55	58	58	22	188	92	100	130	80	<sup>-0,030</sup> <sub>-0,076</sub>	215	341	337	86	267
200	110	100	<sup>+0,000</sup> <sub>-0,020</sub>	245	1 1/4	57	70	76	76	24	242	116	120	165	100	<sup>-0,036</sup> <sub>-0,090</sub>	279	439	415	98	323

All dimensions in millimetres unless otherwise stated.

\*Add stroke to all starred dimensions.

<sup>1</sup>Head depth increased by 5mm to accommodate port on 25mm and 32mm bore cylinders. See page 19.

## Double Rod Cylinders

### Double Rod Cylinder

Available in all mounts except MP5

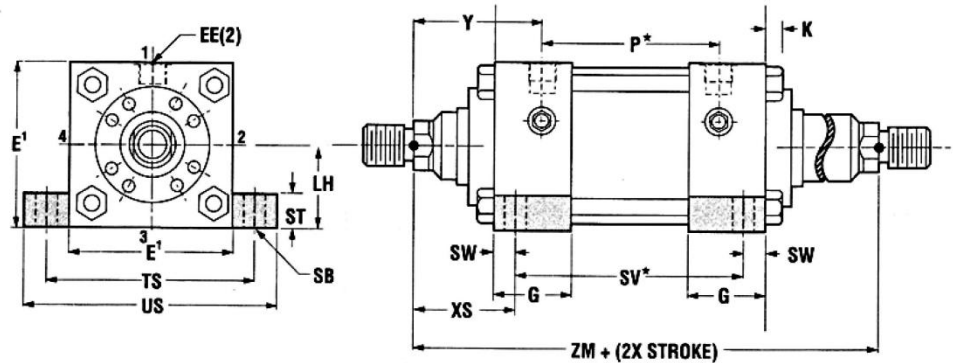

Example shown: MHD-MS2-DR - Side Lugs - Double Lugs

## Double Rod Dimensions

Bore Dia.	Road Dia.	LD*	P*	SV*	ZM**
25	12	104	53	88	154
	18				
32	14	108	56	88	178
	22				
40	18	125	73	105	195
	28				
50	22	125	74	99	207
	36				
63	28	127	80	93	223
	45				
80	36	144	93	110	246
	56				
100	45	151	101	107	265
	70				
125	56	175	117	131	289
	90				
160	70	188	130	130	302
	110				
200	90	242	160	172	356
	140				

All dimensions in millimetres unless otherwise stated.

\*Add stroke to all starred dimensions.

\*\*Add 2x stroke to all these dimensions.

## Technical Data

### Series Hydraulic Pressure Ratings

Hydraulic Pressure Ratings			
Cylinder Bore (mm)	Piston Rod Dia.(mm)	Design Pressures (bar)	
		4:1 Tensile	4:1 Yield
25	12	304	253
	18	265	196
32	14	229	170
	22	229	170
40	18	231	193
	28	287	212
50	22	195	162
	36	233	186
63	28	199	166
	45	223	178
80	36	220	176
	56	220	176
100	45	179	143
	70	179	143
125	56	203	165
	90	203	165
160	70	188	157
	110	199	161
200	90	191	155
	140	191	155

#### Optional features available

- Gland drains
- Stroke adjusters
- Rod end gaiters
- Metallic rod wires
- Stainless steel piston rods
- DC proximity-end of stroke switches
- Position feed back transducers
- Single acting cylinders
- Spring return or extended cylinder
- Tie rod supports

#### Maximum Pressure

MHI and MHD cylinders are designed to comply with ISO 6020/2 and DIN 24554 mounting dimensions. Whilst the standard requires cylinders to operate at 160 bar, careful selection of materials permits SWP cylinders to operate at 210 bar.

#### Minimum Pressure

MHI and MHD cylinders operate at a minimum pressure of 5 bar, for pressures lower than 5 bar, consult the factory.

#### Pressure Envelope

Pressures developed within a cylinder may be greater than the operating pressure. This may be due to pressure intensification across the piston or cushions and lead to fatigue failure of the cylinder tube. It is important that pressure intensification does not exceed 340 bar.

#### Seals

Standard seals operate at temperatures between -20°C to +80°C. For operating conditions outside this range, consult factory. Sealing materials used in standard cylinders are suitable for use with most petroleum based hydraulic fluids. If there is any doubt regarding seal compatibility with the operating medium, please consult factory.

#### Stroke Tolerances

Due to a build up of tolerances within the cylinder standard stroke lengths are 0 to +2mm. Please consult factory for closer tolerances.

## Ports, Locations and Piston Speeds

### Standard Ports

Series MHI and MHD cylinders are supplied with BSP parallel threaded ports, of a size suitable for normal speed applications - see table opposite. MHI cylinders are also available with metric ports DIN 3852 Part 1. Threaded ports are spot faced for sealing washers.

### Oversize Ports

For higher speed applications, Series MHI and non-standard MHD cylinders are available with oversize BSP or metric ports to the sizes shown in the table opposite, or with extra ports in head or cap faces that are not used for mountings or cushion screws. On 25mm and 32mm bore cylinders, 20mm high port bosses are necessary to provide the full thread length at the cap end. Please contact the factory where these dimensions are critical.

### Port Size and Piston Speed

One of the factors which influences the speed of a hydraulic cylinder is fluid flow in the connecting lines, introduced to or expelled from the cap end port. Due to piston rod displacement, the flow at the cap end port will be greater than that at the head end, at the same piston speed. Fluid velocity in connecting lines should be limited to 5m/s to minimise fluid turbulence, pressure loss and hydraulic shock. The tables opposite are a guide for use when determining whether cylinder ports are adequate for the application. Data shown gives piston speeds for standard and oversize ports and connecting lines where the velocity of the fluid is 5m/s. If the desired piston speed results in a fluid flow in excess of 5m/s in connecting lines, larger lines with two ports per cap should be considered. SWP recommends that a flow rate of 12m/s in connecting lines should not be exceeded.

### Cushions

For piston speeds above 0.1m/s cushions are recommended. Cushions can be located in positions 1 to 4 on both head and cap, provided it is not occupied by port or air bleed.

### Air Bleeds

Are available in positions 1 to 4 provided it is not occupied by a port or cushion.

### Port Locations

Ports are available in positions shown. Ports are also available on the rear cap - position 5 on all mounts except MP1 MP3 MP5.

Bore φ	Standard Cylinder Ports				
	Port Size BSP/G inches	Port Size Metric <sup>1</sup>	Bore of Connecting Lines	Cap End Flow in l/min @ 5m/s	Piston Speed m/s
25	1/4	M14x1.5	7	11.5	0.39
32	1/4	M14x1.5	7	11.5	0.24
40	3/8	M18x1.5	10	23.5	0.31
50	1/2	M22x1.5	13	40	0.34
63	1/2	M22x1.5	13	40	0.21
80	3/4	M27x2	15	53	0.18
100	3/4	M27x2	15	53	0.11
125	1	M33x2	19	85	0.12
160	1	M33x2	19	85	0.07
200	1.1/4	M42x2	24	136	0.07

Bore φ	Oversize Cylinder Ports (Not to DIN 24 554)				
	Port Size BSP/G inches	Port Size Metric <sup>1</sup>	Bore of Connecting Lines	Cap End Flow in l/min @ 5m/s	Piston Speed m/s
25	3/8 <sup>2</sup>	M18x1.5 <sup>2,3</sup>	10	23.5	0.80
32	3/8 <sup>2</sup>	M18x1.5 <sup>2,3</sup>	10	23.5	0.48
40	1/2	M22x1.5 <sup>3</sup>	13	40	0.53
50	3/4	M27x2 <sup>3</sup>	15	53	0.45
63	3/4	M27x2 <sup>3</sup>	15	53	0.28
80 <sup>4</sup>	1	M33x2	19	85	0.28
100 <sup>4</sup>	1	M33x2	19	85	0.18
125 <sup>4</sup>	1.1/4	M42x2	24	136	0.18
160 <sup>4</sup>	1.1/4	M42x2	24	136	0.11
200 <sup>4</sup>	1.1/2	M48x2	30	212	0.11

- 1 Not to DIN 24 554
- 2 20mm high port bosses fitted at cap end
- 3 Consult factory - available on certain bore sizes only  
Not recommended for ME5 mountings at pressures above 100 bar

### Port Locations

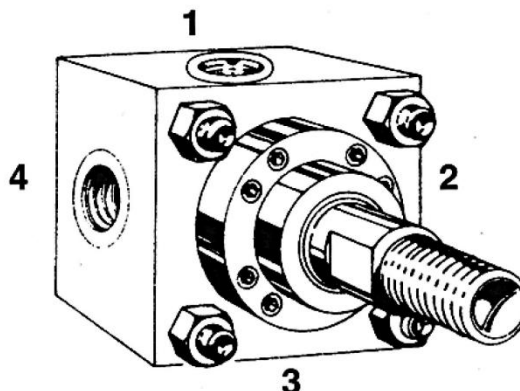



## Rod Size and Stop Tube Selection

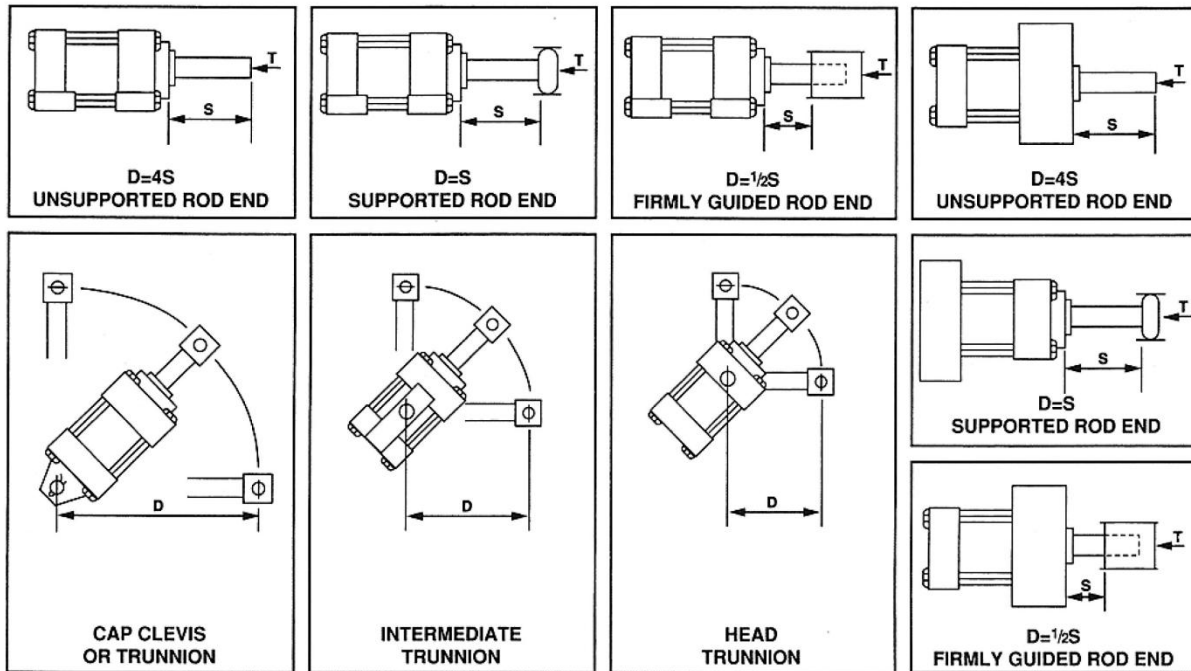

### Rod Size Selection:

Standard rod sizes are normally suitable for all applications except for long stroke or high thrust applications. Proper selection of minimum rod size may be determined by the following steps:

1. With knowledge of bore size and operating pressure, thrust may be determined. Refer to top of page 18.
2. Select from illustrations above the type of mounting to be used and determine the length of "D" with the piston rod in the fully extended position.
3. Find the value of "D" at the bottom of the column strength graph and follow its line vertically until it intercepts the horizontal line representing the maximum push thrust that will be applied to your cylinder. The intersection of these two lines will fall within a stripe representing the minimum recommended piston rod diameter for your application.

### Stop Tubes:

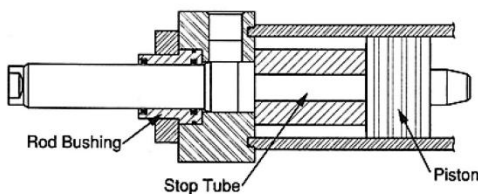

Stop tubes are located between the piston and the rod shoulder on the head end of the cylinder. Bearing loading is reduced by separating the piston and the rod bushing. Bearing wear and tendency to buckle is reduced.

To determine if a stop tube is required and the length of stop tube needed, use the following procedure:

Determine the value of "D" with the piston rod in the fully extended position. If the value of "D" is under 1000mm, no stop tube is needed. If "D" is greater than 1000mm, 25mm of stop tube is recommended for each 250mm or fraction thereof beyond 1000mm.

**Special note: When specifying stroke and stop tube lengths, please include net working stroke plus stop tube length.**

### Column Strength

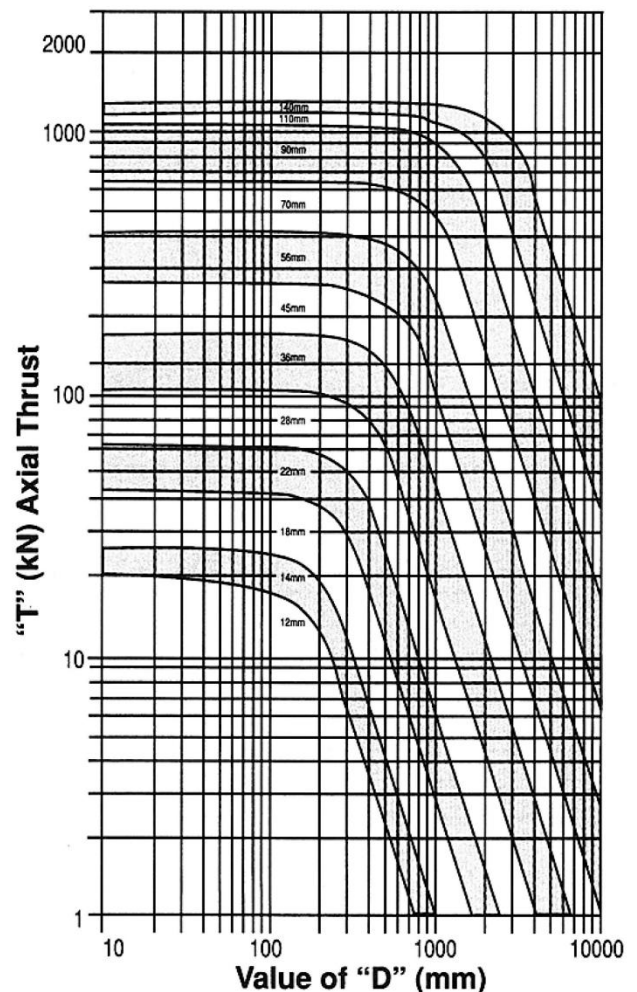

## Technical Data

### Pressure-Thrust-Consumption Charts

To determine thrusts or pressures not shown in the tables, add thrusts for two or more operating pressures which combined equal the desired pressure.

Cylinder Bore  (mm)	Piston Area  (mm <sup>2</sup> )	Out-Stroke Thrust in kiloNewtons					Consumption Per 0,01 metres of Stroke in One Direction
		Pressure of Operating Medium (bar)					Oil Displaced (litres)
		10	40	100	160	210	
25	490,9	0,49	1,96	4,91	7,85	10,31	0,0049
32	804,2	0,80	3,22	8,04	12,87	16,89	0,0080
40	1256,6	1,26	5,03	12,57	20,11	26,39	0,0126
50	1963,5	1,96	7,85	19,63	31,42	41,23	0,0196
63	3117,2	3,12	12,47	31,17	49,88	65,46	0,0312
80	5026,5	5,03	20,11	50,27	80,42	105,56	0,0503
100	7854,0	7,85	31,42	78,54	125,66	164,39	0,0785
125	12271,8	12,27	49,09	122,72	196,35	257,71	0,1227
160	20106,2	20,11	80,42	201,06	321,70	422,23	0,2011
200	31415,9	31,42	125,66	314,16	502,65	659,73	0,3142

Deduct the following forces or consumptions corresponding to rod size from Out-Stroke Thrusts or Consumptions to determine In-Stroke Pull or Consumptions.

Piston Rod		In-Stroke Pull Subtraction Values in kiloNewtons					Consumption Subtraction Value Per 0,01 metres of Stroke in One Direction
		Pressure of Operating Medium (bar)					Oil Displaced (litres)
		10	40	100	160	210	
Diameter (mm)	Area (mm <sup>2</sup> )						
12	113,1	0,11	0,45	1,13	1,81	2,38	0,0011
14	153,9	0,15	0,62	1,54	2,46	3,23	0,0015
18	254,5	0,25	1,02	2,54	4,07	5,34	0,0025
22	380,1	0,38	1,52	3,80	6,08	7,98	0,0038
28	615,8	0,62	2,46	6,16	9,85	12,93	0,0062
36	1017,9	1,02	4,07	10,18	16,29	21,38	0,0102
45	1590,4	1,59	6,36	15,90	25,45	33,40	0,0159
56	2463,0	2,46	9,85	24,63	39,41	51,72	0,0246
70	3848,5	3,85	15,39	38,48	61,58	80,82	0,0385
90	6361,7	6,36	25,45	63,62	101,79	133,60	0,0636
110	9503,3	9,50	38,01	95,03	152,05	199,57	0,0950
140	15393,8	15,39	61,58	153,94	246,30	323,27	0,1539

### Rod End Styles 2 & 7 - All Except ME5 Mount

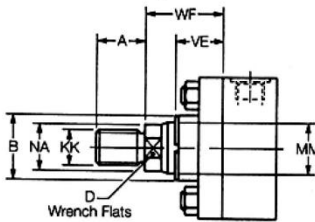

### Rod End Styles 2 & 7 ME5 Mount

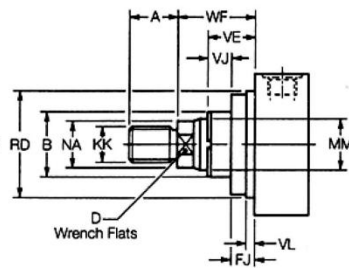

### Rod End Style 9 - All Except ME5 Mount

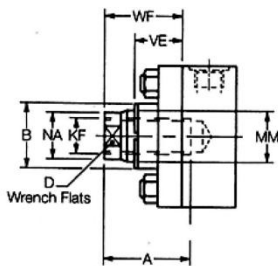

### Rod End Style 9 ME5 Mount

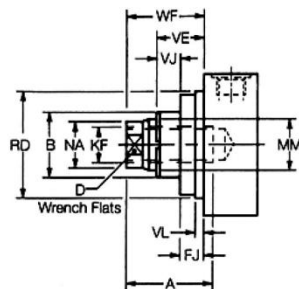

## Piston Rod End Styles

### Rod End Styles 2 & 7

The smallest diameter rod end thread for each bore size is designated Style 2 when supplied with a No.1 rod. When the same rod end thread is supplied with a No.2 or No.3 rod, it is designated Style 7.

### 25 & 32mm Bore Cylinders

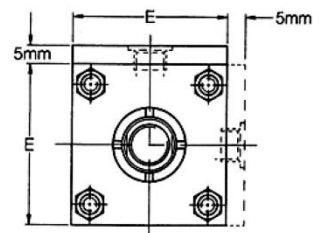

### Rod End Style 9 - Short Stroke Cylinders

Style 9 (female) rod ends should not be used on 160mm or 200mm bore cylinders with a stroke of 50mm or less. Please consult the factory, with details of the application.

5mm extra height applies to port face at head end only.

## Piston Rod End Dimensions

Bore $\phi$	Rod No.	MM Rod $\phi$	Style 2		Style 7		Style 9		B <sub>19</sub>	D	NA	VE	WF	ME5 Mount Only			
			KK	A	KK	A	KF	A						VL min	RD <sub>18</sub>	VJ	FJ
25	1	12	M10x1.25	14	-	-	M8x1	14	24	10	11	16	25	3	38	6	10
	2	18	M14x1.5	18	M10x1.25	14	M12x1.25	18	30	15	17	16					
32	1	14	M12x1.25	16	-	-	M10x1.25	16	26	12	13	22	35	3	42	12	10
	2	22	M16x1.5	22	M12x1.25	16	M16x1.5	22	34	18	21	22					
40	1	18	M14x1.5	18	-	-	M12x1.25	18	30	15	17	16	35	3	62	6	10
	2	28	M20x1.5	28	M14x1.5	18	M20x1.5	28	42	22	26	22					
50	1	22	M16x1.5	22	-	-	M16x1.5	22	34	18	21	22	41	4	74	6	16
	2	36	M27x2	36	M16x1.5	22	M27x2	36	50	30	34	25					
	3	28	M20x1.5	28	M16x1.5	22	M20x1.5	28	42	22	26	22					
63	1	28	M20x1.5	28	-	-	M20x1.5	28	42	22	26	22	48	4	75	6	16
	2	45	M33x2	45	M20x1.5	28	M33x2	45	60	39	43	29					
	3	36	M27x2	36	M20x1.5	28	M27x2	36	50	30	34	25					
80	1	36	M27x2	36	-	-	M27x2	36	50	30	34	25	51	4	82	5	20
	2	56	M42x2	56	M27x2	36	M42x2	56	72	48	54	29					
	3	45	M33x2	45	M27x2	36	M33x2	45	60	39	43	29					
100	1	45	M33x2	45	-	-	M33x2	45	60	39	43	29	57	5	92	7	22
	2	70	M48x2	63	M33x2	45	M48x2	63	88	62	68	32					
	3	56	M42x2	56	M33x2	45	M42x2	56	72	48	54	29					
125	1	56	M42x2	56	-	-	M42x2	56	72	48	54	29	57	5	105	9	20
	2	90	M64x3	85	M42x2	56	M64x3	85	108	80	88	32					
	3	70	M48x2	63	M42x2	56	M48x2	63	88	62	68	32					
160	1	70	M48x2	63	-	-	M48x2	63	88	62	68	32	57	5	125	10	22
	2	110	M80x3	95	M48x2	63	M80x3	95	133	100	108	32					
	3	90	M64x3	85	M48x2	63	M64x3	85	108	80	88	32					
200	1	90	M64x3	85	-	-	M64x3	85	108	80	88	32	57	5	150	10	22
	2	140	M100x3	112	M64x3	85	M100x3	112	163	128	138	32					
	3	110	M80x3	95	M64x3	85	M80x3	95	133	100	108	32					

All dimensions are in millimetres unless otherwise stated.



## AC Hydraulics Ltd offers the following product lines and services

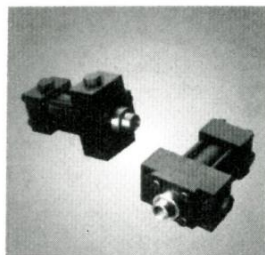

### HY SERIES

- NFPA Interchangeable
- 3000/5000 psi rated
- All steel construction

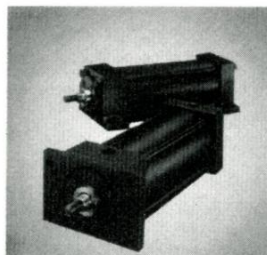

### ASL/ASH SERIES

- NFPA Interchangeable
- ASL – to 250 psi pneumatic
- ASH – 1500 psi nominal hydraulic

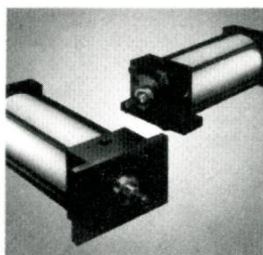

### ASQ SERIES

- NFPA Interchangeable
- ASQ – to 250 psi pneumatic
- AHQ – to 400 psi hydraulic
- Aluminum construction

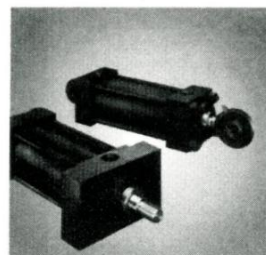

### MHI/MHD SERIES

- Conform to international metric specifications
- IHM – ISO 6020/2
- DHM – DIN 24 554
- 210 BAR nominal hydraulic
- All steel construction

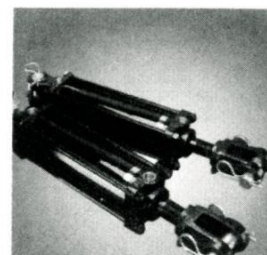

### AG SERIES

- WorkHorse Line
- ASAE Interchangeable agricultural cylinders
- Non ASAE also available
- 2500 psi hydraulic

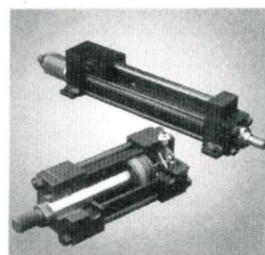

### ECS SERIES

- Hydraulic or pneumatic cylinders incorporate various stroke sensing and feedback devices.
- Available in all models.
- Manifold designs also available.

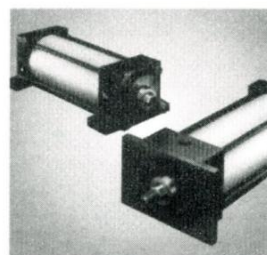

### ASV SERIES

- NFPA Interchangeable
- To 200 psi pneumatic
- Aluminum construction

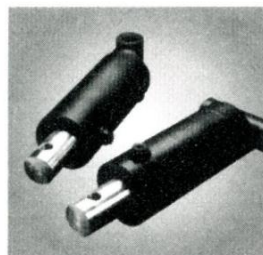

### WH SERIES

- Welded construction
- WH – Industrial grade, 3000 psi hydraulic
- WHM – WorkHorse Line, mobile grade, to 3000 psi hydraulic

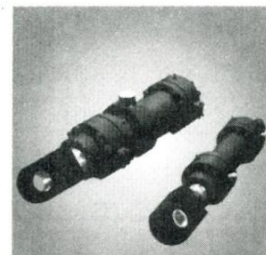

### SMMA & SMMB SERIES

- Mill duty construction to CETOP RP58H and RP73H standards

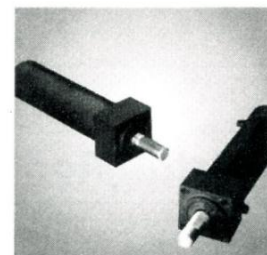

### SS/HSS SERIES

- SpaceSaver series cylinders
- Threaded Body, Round Line construction
- HSS – to 1000 psi hydraulic
- SS – to 200 psi pneumatic

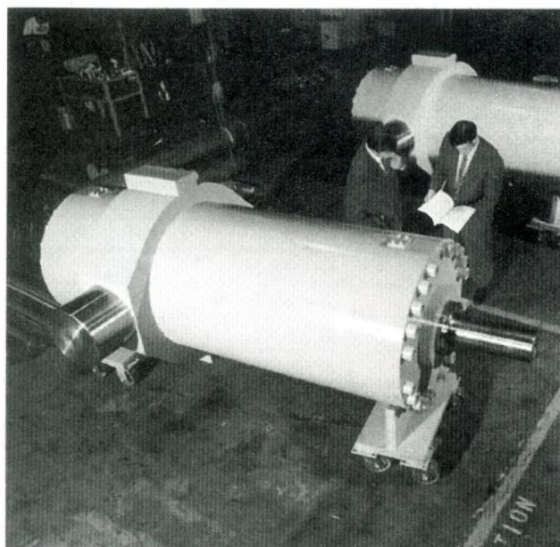

### CUSTOM CYLINDER

- Custom cylinders to meet all special requirements.
- Bores to 60" (1500mm)
- Strokes to 65 feet (20 meters)
- Pressures to 10,000 psi (700 BAR) or higher

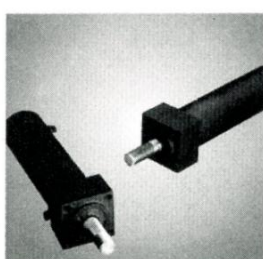

### SMM/SMI SERIES

- Mill duty construction
- Conform to international metric specifications
- SMM – ISO 3320 and DIN 24 334, hydraulic 250/350 BAR
- SMI – ISO 6022, hydraulic 250 BAR

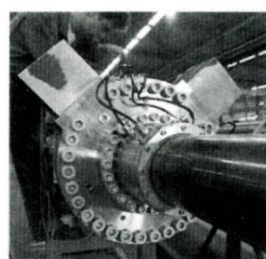

### ALTIOX®/HYPOS® SERIES

- Altiox 300® metal oxide rod coating for superior corrosion protection.
- Hypos® stroke sensing for up to 60 feet.

### OTHER ACTUATOR TYPES

- Rotary Actuators
- Boosters
- Air/Oil Tanks
- Plastic/Composite Cylinders
- Food Service Cylinders
- Stainless Steel Cylinders
- Water Service Cylinders
- Low Friction Cylinders
- Ram Type Cylinders
- Custom Cylinders

### SPECIFICATIONS MANUFACTURED TO:

NFPA, ISO 6020/2, ISO 6022, ISO 3220, DIN 24 334, DIN 24 554, ABS, DNV, USCG, AASHTO, JIS, ANSI, AWS, ASTM, CETOP RP58H & RP73H

**Extensive repair & rebuild facility for all makes of cylinder.**