



Swing Clamps with Overload Protection Device

cartridge type, double acting, max. operating pressure 500 bar



Advantages

- Compact design
- Double-acting function
- Unimpeded loading and unloading of the fixture
- Mounting position: variable
- Body partially recessible
- Counterbore for flange of the body can be easily manufactured by a milling cutter, since the flange has rounded edges
- Oil supply through drilled channels
- FKM wiper standard
- Metallic wiper for protection of the piston rod available

Connecting possibility

Drilled channels

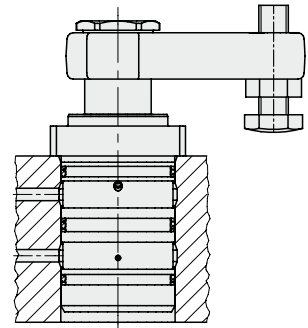

Application

Hydraulic swing clamps are used for clamping of workpieces when it is essential to keep the clamping area free of straps and clamping components for unrestricted workpiece loading and unloading.

Function

This hydraulic clamping element is a pull-type cylinder where a part of the total stroke is used to swing the piston.

Swing direction

The units are available with clockwise and counterclockwise swing motion or without swing motion (0°). Starting from the off-position.

Standard swing angles are 45°, 60° and 90° ±2°.

Special angles on request.

0°-Version

Use as pure pull-type cylinder with a piston which is secured against torsion and which allows eccentric load as per clamping force diagram.

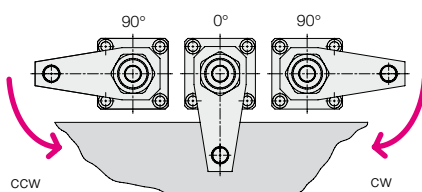

Overload protection device

An integrated mechanical overload protection device prevents damage to the swing mechanism when striking an object within the 90° swing motion, clamping or unclamping alike, or in case of incorrect mounting of the clamping arm.

Material

By nitrating wear is reduced and protection against corrosion increased.

Piston material: high alloy steel.

Cylinder body: free cutting steel.

Important notes

Operating conditions, tolerances and other data see data sheet A 0.100.

Metallic wiper
optional

Option: metallic wiper

In addition to the FKM wiper all double-acting swing clamps can be equipped with a metallic wiper.

Part-no.: Add only letter "M" to the part number of the swing clamp without metallic wiper.

Example of ordering:

Swing clamp 1895-202

with metallic wiper: **1895-202M**

Application example

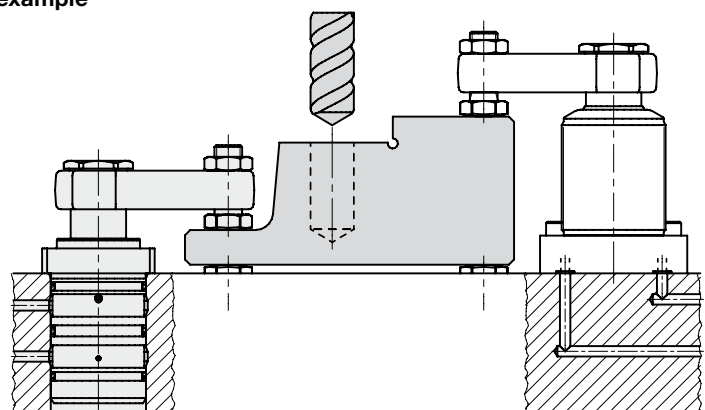

Dimensions Technical characteristics

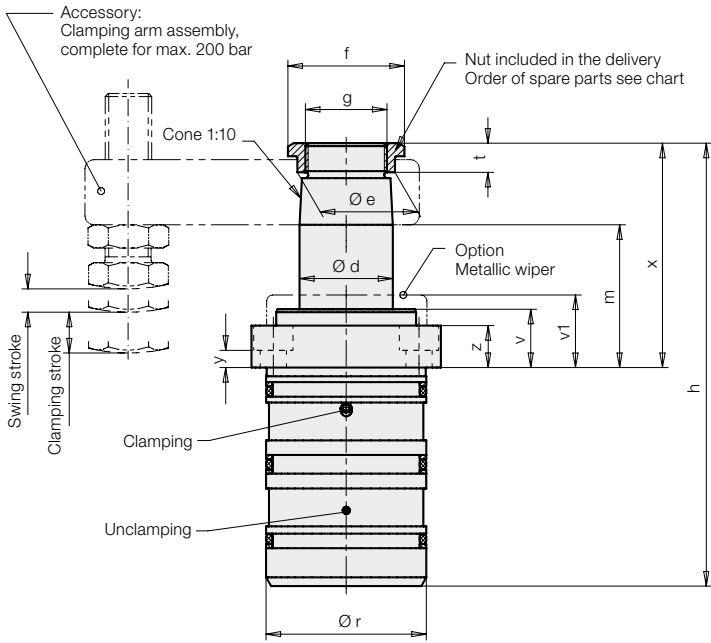

Location hole for oil bore $\varnothing 5 / \varnothing 6$

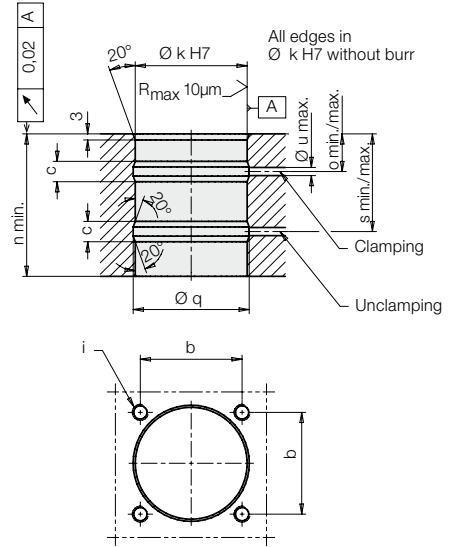

Location hole for oil bore $\varnothing 3$

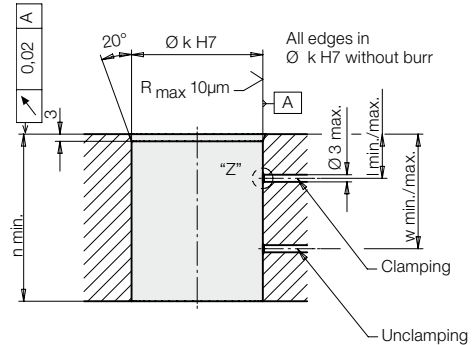

Effective clamping force F_{Sp} as a function of the clamping pressure p

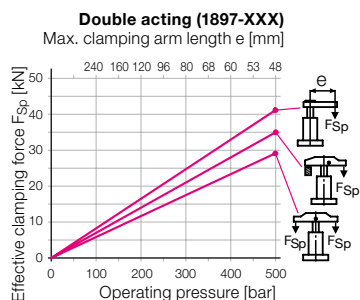
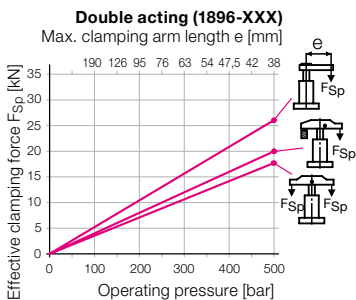
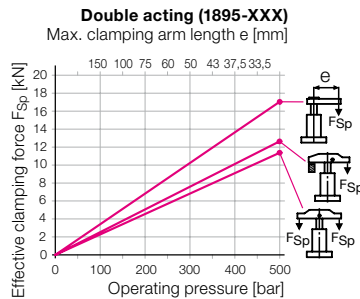
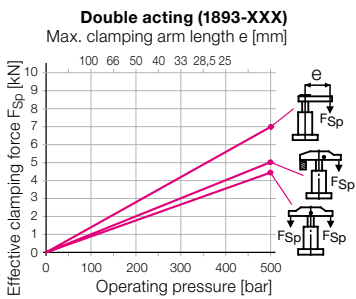

Example 1: 1895-102

An operating pressure p of 200 bar in connection with standard clamping arm 0354-003 of max. arm length L = 75 mm results in an effective clamping force F_{Sp} of 6.8 kN.

Example 2: 1895-102

For a desired effective clamping force F_{Sp} of 8 kN and use of a swing clamp 1895-102 with a standard clamping strap 0354-002 an operating pressure p of 320 bar is required.

Dimensions Technical characteristics

		Size 1		Size 2		Size 3		Size 4	
Clamping stroke	[mm]	11	25	14	25	15	25	15	25
Swing stroke	[mm]	7	9	8	10	11	11	9	12
Total stroke	[mm]	18	34	22	35	26	36	24	37
Operating pressure. min.	[bar]	30	30	30	30	30	30	30	30
Max. oil flow rate	[cm ³ /s]	3.2	3.2	10	10	18.4	18.4	27.7	27.7
Oil volume / stroke	[cm ³]	3.2	6	10	16	18.4	25.5	27.7	43
Oil volume / return stroke	[cm ³]	8.8	17	27.7	44	51	71	75	116
Ø d	[mm]	20	20	32	32	40	40	50	50
a	[mm]	55	55	65	65	85	85	100	100
b	[mm]	40	40	50	50	65	65	75	75
c	[mm]	10	10	10	10	12	12	12	12
Ø e	[mm]	23.5	23.5	33.5	33.5	45	45	55.5	55.5
f	[mm]	30	30	40	40	55	55	68	68
g	[mm]	M 18x1.5	M 18x1.5	M 28x1.5	M 28x1.5	M 35x1.5	M 35x1.5	M 45x1.5	M 45x1.5
h	[mm]	125.5	157.5	152	178	172	192	183	209
i	[mm]	M 6	M 6	M 8	M 8	M 10	M 10	M 12	M 12
Ø k H7	[mm]	42	42	55	55	70	70	85	85
l min. / max.	[mm]	13.5 / 21.5	13.5 / 21.5	14.5 / 22.5	14.5 / 22.5	15.5 / 26.5	15.5 / 26.5	18.5 / 29.5	18.5 / 29.5
m -1	[mm]	43	59	49	62	60	70	62	75
n min.	[mm]	60	76	66	79	72	82	76	89
o min. / max.	[mm]	16 / 19	16 / 19	17 / 20	17 / 20	19 / 23	19 / 23	22 / 26	22 / 26
Ø p	[mm]	6.6	6.6	9	9	11	11	14	14
Ø q	[mm]	44	44	57	57	72	72	87	87
Ø r f7	[mm]	42	42	55	55	70	70	85	85
s min. / max.	[mm]	41.5 / 44.5	41.5 / 60.5	46.5 / 49.5	46.5 / 62.5	49.5 / 53.5	49.5 / 63.5	52 / 56	52 / 69
t	[mm]	9	9	10	10	11	11	12	12
Ø u max.	[mm]	5	5	5	5	6	6	6	6
v	[mm]	18	18	20	20	24	24	28	28
v1	[mm]	23	23	25	25	30	30	34	34
w min. / max.	[mm]	39 / 47	39 / 63	44 / 52	44 / 65	45.5 / 56.5	45.5 / 66.5	48.5 / 59.5	48.5 / 72.5
x	[mm]	64	80	77	90	94	104	102	115
y	[mm]	6.5	6.5	6	6	8.5	8.5	10.5	10.5
z	[mm]	13.5	13.5	14.5	14.5	19.5	19.5	23.5	23.5
Declutch moment of overload protection	[Nm]	3.5	3.5	11	11	17	17	30	30

Double acting

Part-no.

Swing direction 90° cw	1893-102	1893-302	1895-102	1895-302	1896-102	1896-302	1897-102	1897-302
Swing direction 90° ccw	1893-202	1893-402	1895-202	1895-402	1896-202	1896-402	1897-202	1897-402
0 degree	1893-242	1893-442	1895-242	1895-442	1896-242	1896-442	1897-242	1897-442
Spare nut	3527-014		3527-015		3527-048		3527-016	
Metallic wiper (spare part)	0341-107		0341-100		0341-101		0341-102	

Code numbers for available swing angles

Swing angle	Part-no.
90°	18XX-X0X
60°	18XX-X2X
45°	18XX-X3X

Option - metallic wiper

Part-nos.: **189X-XXXM**

Important notes

1. Danger of injury

Hydraulic clamping elements can generate considerable forces. Due to the 90° swing motion, the exact clamping and unclamping position cannot be determined in advance. Considerable injuries can be caused to fingers in the effective area of the clamping arm. Remedy: protection device with electrical locking.

2. Admissible oil flow rate

In case of the admissible oil flow rate as per chart the shortest possible clamping time is 1 second. If the oil volume is bigger, the overload protection device can snap out. Due to the oil supply through drilled channels, throttling will be nearly impossible. Therefore this line is equipped with a standard throttle bore hole in the body. Thereby a more regular motion of several connected swing clamps will be obtained and the flow rate limited. Nevertheless an additional throttling can be required when using longer clamping arms with bigger weight to avoid snapping out of the overload protection device.

3. Unimpeded swing motion

The swing motion must not be impeded and the clamping arm may only contact the workpiece after completion of the swing stroke.

4. Clamping arm assembly

When tightening and untightening the lock nut, the clamping arm has to be backed up to avoid the introduction of moments to the piston rod and thereby any deterioration of the swing mechanism.

5. Adjustment of contact bolt

The contact bolt may only contact the workpiece after completion of the swing motion. When tightening and untightening the fixing screw, the clamping arm as to be backed up (see 4.)

6. Special clamping arm

When using special clamping arms with other lengths, the corresponding operating pressures as shown in the clamping force diagram must not be exceeded. If longer clamping arms will be used, not only the operating pressure but also the flow rate have to be reduced (see 2.).

7. Option: metallic wiper

This wiper protects the FKM wiper against mechanical damage, e.g. by hot swarf. The swing clamp body is prepared for mounting of the metallic wiper. The wiper consists of a radially floating wiping disk and a retaining disk which will be pressed onto the existing collar.

8. Bleeding

Air in the oil prolongs the clamping time considerably and leads to function troubles. Therefore bleeding has to be effected during start up.

In case of drilled channels provide additional bleeding screws.

Accessories

Dimensions for special clamping arms

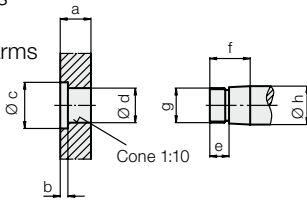

Swing clamp	a	b	Øc	Ød ^{+0.10} _{+0.05}	e	f	g	Øh _{f7}
18X3-XXX	16	4	24	19.8	10	21	M 18x1.5	20
18X5-XXX	23	5	34	31.8	12	28	M 28x1.5	32
18X6-XXX	28	5	46	39.8	12	34	M 35x1.5	40
18X7-XXX	34	6	56	49.8	13	40	M 45x1.5	50

Clamping arm, max. 300 bar

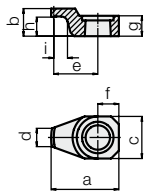

Swing clamp	a	b	c	d	e	f	g	h	i	Weight [kg]	Part-no.
18X3-XXX	51.5	21	32	14	33.5	16	15.5	14.5	7	0.11	3548-238
18X5-XXX	76	28	46	25	50	23	22.5	19	7	0.3	3548-236
18X6-XXX	100	34	66	39	64	33	28	23	7	0.84	3548-301
18X7-XXX	123	40	75	39	82.5	37.5	34	27	8	1.3	3548-302

Material: 42CrMo4

Clamping arm assembly, complete, max. 200 bar

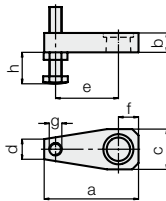

Swing clamp	a	b	c	d	e	f	g	h max.	h min.	Weight [kg]	Part-no.
18X3-XXX	75	16	32	16	50	16	M10	64	6	0.2	0354-001
18X5-XXX	115	23	48	22	75	25	M16	79	9	0.7	0354-003
18X6-XXX	140	28	60	28	95	30	M16	79	9	2.0	0354-042
18X7-XXX	178	34	78	40	120	40	M20	98	12	2.55	0354-005

Swing clamp	a	b	c	d	f	Weight [kg]	Part-no.
18X3-XXX	75	16	32	16	16	0.18	3921-016
18X5-XXX	115	23	48	22	25	0.65	3921-017
18X6-XXX	140	28	60	28	30	1.85	3921-021
18X7-XXX	178	34	78	40	40	2.3	3921-018

Material: 42CrMo4

Clamping strap assembly, complete, with carrier, max. 500 bar

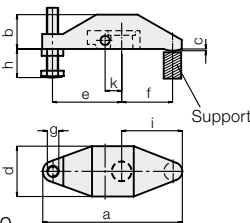

Swing clamp	a	b	c	d	e	f	g	h max.	h min.	i	k	Weight [kg]	Part-no.
18X3-XXX	122	30	1.5	44	60	45	M10	64	6	53	14.5	0.57	0354-000
18X5-XXX	185	45	2	58.5	83	75	M16	79	9	87	21	1.58	0354-002
18X6-XXX	203	54	2.5	82	92	82	M16	79	9	95	28	3.45	0354-041
18X7-XXX	223	59	2.5	98	100	90	M20	98	12	105	33	4.75	0354-004

Material: GGG-40

Carrier

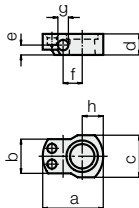

Swing clamp	a	b	c	d	e	f	g ^{H7}	h	Weight [kg]	Part-no.
18X3-XXX	46	26	32	16	7.5	14.5	8	16	0.08	3542-093
18X5-XXX	59	32	40	23	13	21	10	22	0.16	3542-094
18X6-XXX	82	44.5	58	28	17	28	12	34	0.5	3542-132
18X7-XXX	90	56	68	34	21	33	14	36	0.65	3542-096

Material: C 45

Double clamping arm assembly, complete, with carrier, max. 500 bar

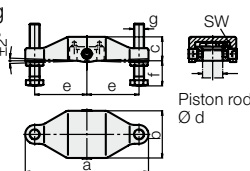

Swing clamp	a	b	c	Ød	e	f min.	f max.	g	SW	Weight [kg]	Part-no.
18X3-XXX	138	59	28.5	20	60	10	64	M 10	5	0.83	0354-131
18X5-XXX	196	75	38	32	83	15	79	M 16	8	2.11	0354-132
18X6-XXX	216	85	47	40	92	15	79	M 16	8	3.17	0354-133
18X7-XXX	236	105	56	50	100	19	98	M 20	8	5.24	0354-134

Material: GGG-40

Carrier, complete with threaded bolt and spring clamping elements

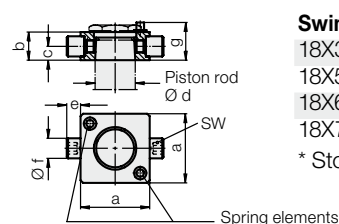

Swing clamp	a ^{±0.1}	b	c	Ød	e	Øf ^{g6}	g*	SW	Part-no.
18X3-XXX	43	16	7.5	20	9	10	21.5	5	0354-141
18X5-XXX	55	23	11	32	11	16	29	8	0354-142
18X6-XXX	63	28	15	40	12	18	35	8	0354-143
18X7-XXX	77	34	17	50	15	20	41	8	0354-144

* Stop surface for spring elements

Material: C 45