

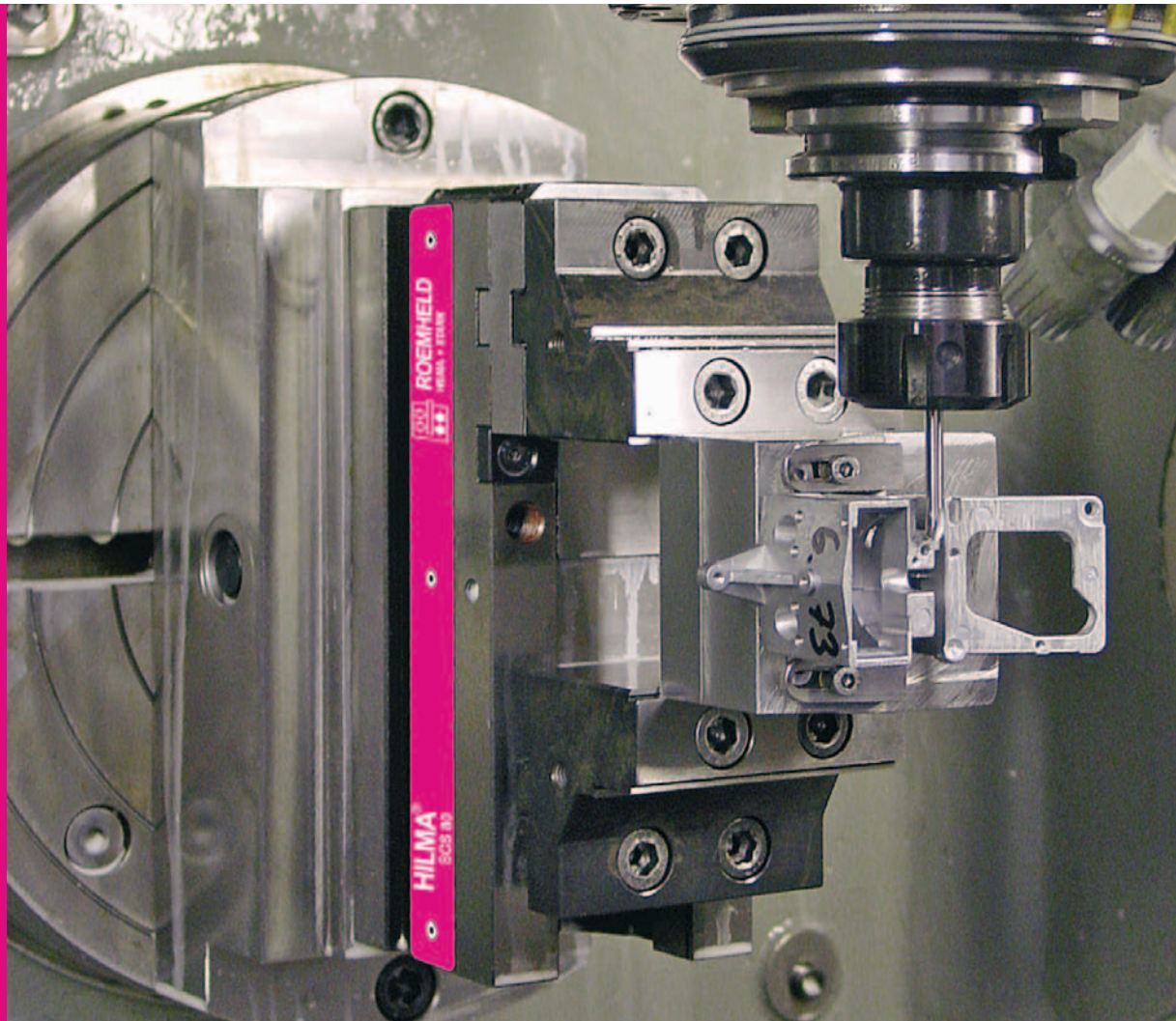

**ROEMHELD**  
HILMA ■ STARK



**Workholding Systems**

**SCS**



SCS workholding systems are ideal for all clamping tasks on 5-axis machining centres and pallet systems. Whether for clamping unmachined parts or for 2nd machining, cubic workpieces are safely clamped against the fixed jaw. The compact design, the stability and the wide range of clamping jaws are further benefits that stand out.

- Design:** Clamping against the fixed jaw
- Width:** 80 or 120 mm
- Operation:** mechanical (SCS 80/120 M) or hydraulic (SCS 80/120 H)

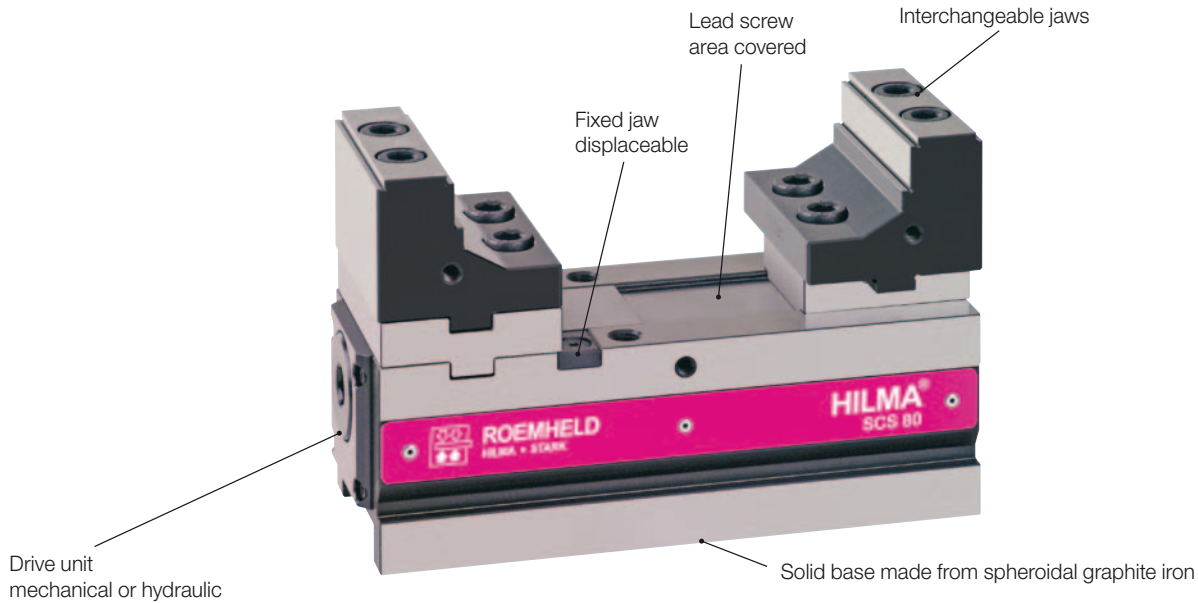

**SCS 80**

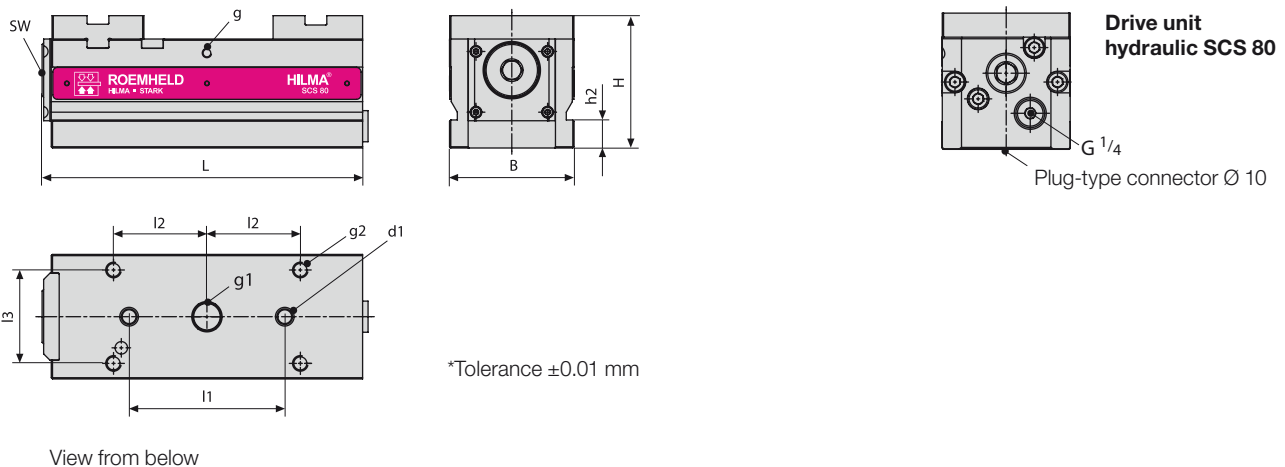

Type	Part no.	Clamping force [kN]	Weight [kg]	Stroke	Dimensions [mm]											
					L	B	H	d1	g	g1	g2	h2	l1	l2	l3	SW
<b>SCS 80M</b>	<b>9.3672.0121</b>	25/ 60 Nm	8.8		206	80	85*	10F7	M6 x 10	M10 x 11	M10 x 16	18	100*	60	60	12
<b>SCS 80H</b>	<b>9.3682.0121</b>	20/310 bar	9.0	4	227	80	85*	10F7	M6 x 10	M10 x 11	M10 x 16	18	100*	60	60	12

**Customized base design for positioning and mounting on request.**



## SCS 120

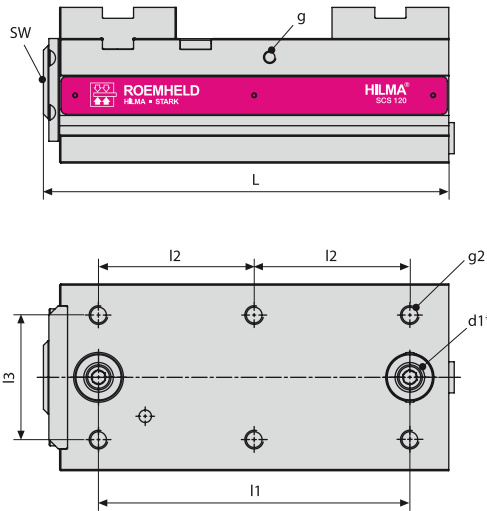

View from below

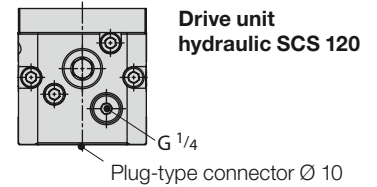
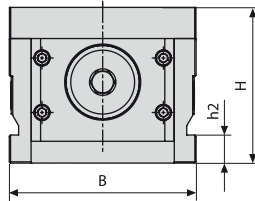

\*Tolerance  $\pm 0.01$  mm

Type	Part no.	Clamping force [kN]	Weight [kg]	Stroke	Dimensions [mm]											
					L	B	H	d1	g	g1	g2	h2	l1	l2	l3	SW
SCS 120 M	9.3673.0121	40/100 Nm	18,4		260	120	100*	25x5 / M10x14	M8x15		M12x18	18	200*	100	80	14
SCS 120 H	9.3683.0121	40/270 bar	20,4	4	282	120	100*	25x5 / M10x14	M8x15		M12x18	18	200*	100	80	14

## Accessory

**Positioning pins, various diameters, for grid plate, 1 set = 2 off**

Type	Part no.	Ø [mm]
SCS 80	9.3920.0101	10/12
SCS120	9.3920.0103	25/12
SCS120	9.3920.0105	25/16

**Positioning pins, various diameters, for table with T-slots, 1 set = 2 off**

Type	Part no.	Ø [mm]
SCS 80	9.3920.0102	10/14
SCS120	9.3920.0104	25/14
SCS120	9.3920.0106	25/18

**T-nuts, 1 set = 6 off**  
for clamping on machine tables

Type	Part no.	Slot [mm]
SCS 80	9.3917.4221	14
SCS120	9.3917.4241	18

**Clamping claws,**  
set with M10 fixing screws

Type	Part no.	1 set = ... off
SCS 80	9.3917.4011	4
SCS120	9.3917.4061	6

**Double clamping claws,**  
set with M10 fixing screws

Type	Part no.	1 set = ... off
SCS 80	9.3917.4021	4
SCS120	9.3917.4071	6

**Workpiece stop**  
for fixation to the base or to the jaws

Type	Part no.
SCS 80	9.3918.4111
SCS120	9.3918.4121

**Torque wrench**

Type	Part no.	Clamping force [Nm]
SCS 80	9.3583.7010	5 – 60
SCS120	9.3792.6610	20 – 120

**Socket** for torque wrench

Type	Part no.	SW
SCS 80	1.3124.0024	12, 3/8"
SCS120	1.3124.0023	14, 1/2"

**Rapid change block Quintus**

Size 1 and 2  
See data sheet 5.3580

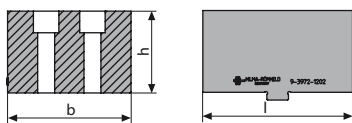
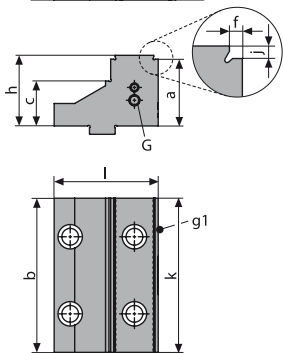
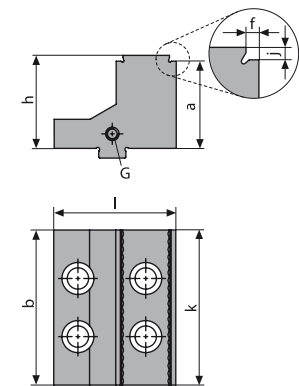
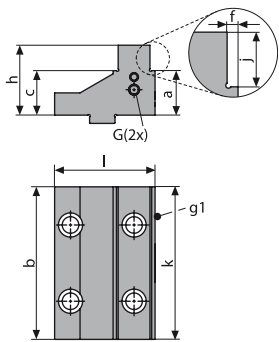
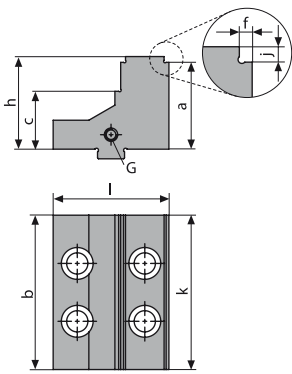

\* Tolerance ±0.01 mm  
\*\* Tolerance ±0.02 mm

**Precision step reversible jaw for SCS 80**

Type	Part no.	Dimensions [mm]								Clamping range		
		l	b	h	a	c	f	G	g1	j	k	min./max.
SCS80	9.3972.1001	60	50	48	45*	30*	2.5	M6 x 10		3	25	5 – 155
SCS80	9.3972.1002	60	50	48	45*	30*	2.5	M6 x 10		3	50	5 – 155
SCS80	9.3972.1003	60	80	48	45*	30*	2.5	M6 x 10		3	80	5 – 155

**Precision step reversible jaw for SCS 120**

Type	Part no.	Dimensions [mm]								Clamping range		
		l	b	h	a	c	f	G	g1	j	k	min./max.
SCS120	9.3973.1001	79	84	55	35*	35*	4	M8 x 14	M4 x 7	20	40	8 – 200
SCS120	9.3973.1002	79	84	55	35*	35*	4	M8 x 14	M4 x 7	20	84	8 – 200
SCS120	9.3973.1003	79	120	55	35*	35*	4	M8 x 14	M4 x 7	20	120	8 – 200

**Special grip jaw for SCS 80** to give max. retention force in the case of high cutting forces

Type	Part no.	Dimensions [mm]								Clamping range		
		l	b	h	a	c	f	G	g1	j	k	min./max.
SCS80	9.3972.1101	63	50	48	45*		3.5	M6 x 10		3	25	7 – 151
SCS80	9.3972.1102	63	50	48	45*		3.5	M6 x 10		3	50	7 – 151
SCS80	9.3972.1103	63	80	48	45*		3.5	M6 x 10		3	80	7 – 151

**Special grip jaw for SCS 120** to give max. retention force in the case of high cutting forces

Type	Part no.	Dimensions [mm]								Clamping range		
		l	b	h	a	c	f	G	g1	j	k	min./max.
SCS120	9.3973.1101	81	84	55	52*	35*	3.5	M8 x 14	M4 x 7	3	40	7 – 195
SCS120	9.3973.1102	81	84	55	52*	35*	3.5	M8 x 14	M4 x 7	3	84	7 – 195
SCS120	9.3973.1103	81	120	55	52*	35*	3.5	M8 x 14	M4 x 7	3	120	7 – 195

**Soft jaw for milling workpiece contours**

Type	Part no.	Dimensions [mm]								Clamping range		
		l	b	h	a	c	f	G	g1	j	k	min./max.
SCS80	9.3972.1201	97	80	53								Steel C 45
SCS80	9.3972.1202	97	80	53								Alu
SCS120	9.3973.1201	97	120	53								Steel C 45
SCS120	9.3973.1202	97	120	53								Alu