

High-pressure spindle, mechanical with integral wedge system



ROEMHELD
HILMA ■ STARK



Original size
Section of high-pressure spindle

Applications:

- in ledges and blocks
- for workpiece and die clamping and locking
- when the available space is limited
- in presses, punching machines and machine tools

Function:

Following manual positioning of the high-pressure spindle against the clamping edge, the wedge system is brought into action by turning the hexagon nut (SW1), and the clamping force is transmitted axially to the clamping point. The required clamping force is achieved by selecting the appropriate torque on the torque wrench (see force-torque diagram). For unclamping, proceed in the reverse order.

Special features:

- ◇ suitable for retrofit
- ◇ compact design allows for multiple clamping
- ◇ clamping force of between 40 and 120 kN
- ◇ high clamping force with low torque
- ◇ self-locking by patented wedge system
- ◇ individually usable



Example of application

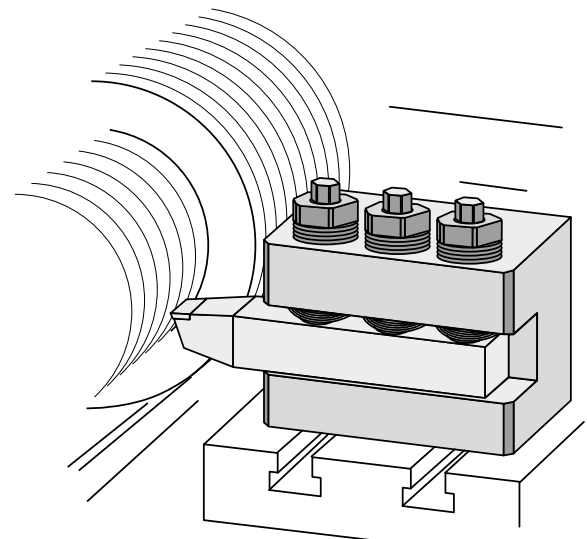



High-pressure spindle, mechanical with integral wedge system

Clamping force (kN)	40	80	120
Clamping stroke (mm)	1,5	2,2	2,5
Max. tightening torque (Nm)	45	90	140
Max. static load (kN)	80	160	240
a (mm)	62	75	90
b (mm)	73	90	110
Ød (mm)	19	28	39
g (mm)	M 36 x 3	M 48 x 3	M 64 x 4
Monitoring of clamping stroke s (mm)	5	7,5	8,5
SW 1 (mm)	13	17	19
SW 2 (mm)	30	41	55
Weight (kg)	0,5	2,0	2,5
Part no.	2272-210	2273-210	2274-210

Other sizes and threads (e.g. indicated in inches) are available on request.

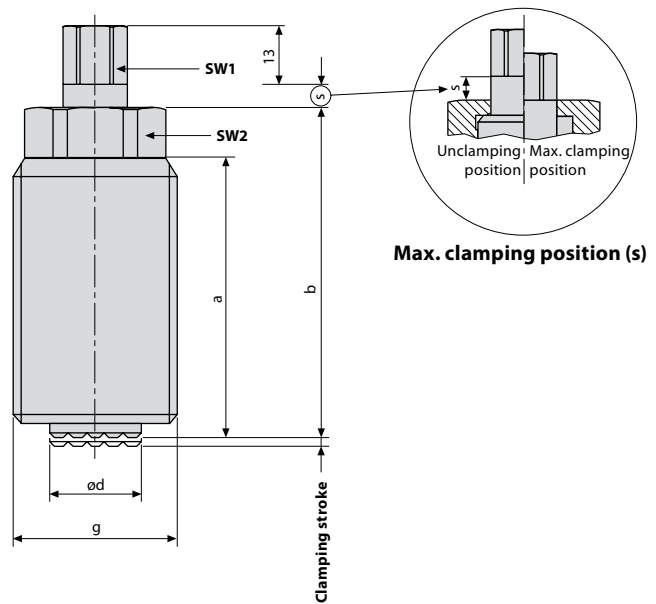

Accessories:

Torque wrench 20 - 100 Nm

Part no. 9.3792.6610

Torque wrench 40 - 200 Nm

Part no. 9.3792.6620

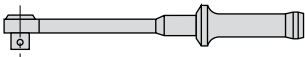
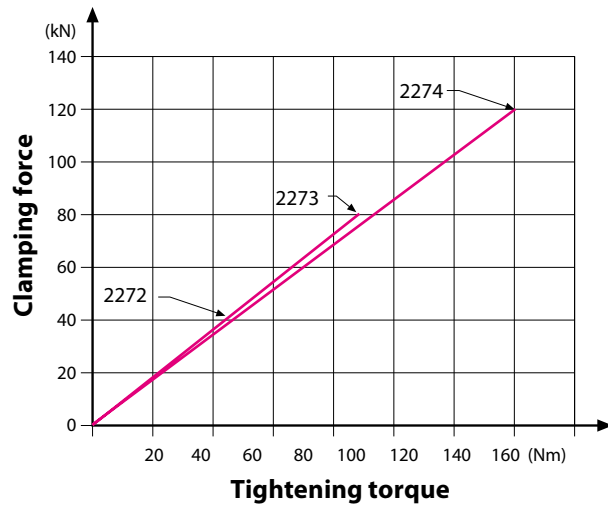

Diagram:

Clamping force - tightening torque



Note:

Before applying the tightening torque, the high-pressure spindle must be screwed against the clamping edge so that there is no play. If the parts are not rigid, tighten the high-pressure spindle using the hexagon nut (SW 2) until there is no play.

High-pressure spindles are permanently lubricated and are maintenance-free under normal conditions of use.