

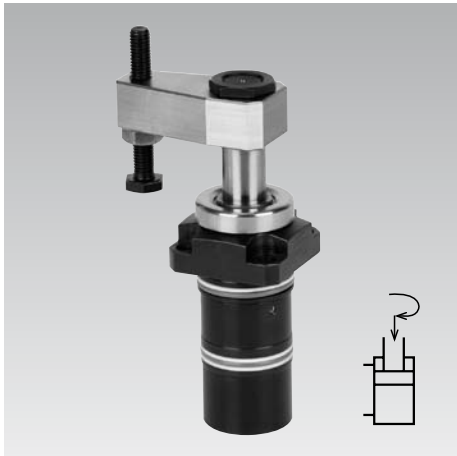

## Swing Clamps with Sturdy Swing Mechanism

### Cartridge type, position monitoring optional, double acting, max. operating pressure 350 bar



#### Advantages

- 4 sizes available
- Short version without bottom cover
- Minimum flange dimensions
- High clamping force at low pressures
- Sturdy swing mechanism
- Insensitive against high flow rates
- Indexing of the clamping arm in a specified position is possible
- Special swing angle easily realizable
- Standard FKM wiper
- Metallic wiper optional
- Mounting position: any

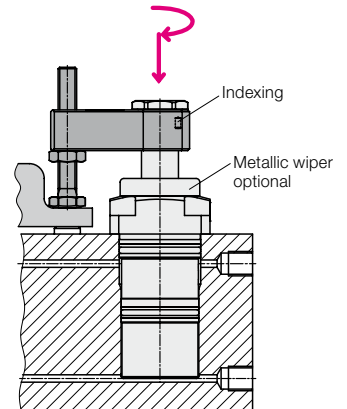

#### Application

Hydraulic swing clamps are used for clamping of workpieces, when it is essential to keep the clamping area free of straps and clamping components for unrestricted workpiece loading and unloading.

Due to the sturdy swing mechanism these swing clamps are particularly suited for:

- Automatic manufacturing systems
- Clamping fixtures with workpiece loading via handling systems
- Transfer lines
- Test systems for motors, gears and axes
- Assembly lines
- Special machine tools

#### Description

The hydraulic swing clamp is a pull-type cylinder where a part of the total stroke is used to swing the piston.

The favourable area ratio (piston/piston rod) allows high clamping forces already at relatively low oil pressures.

For high flow rates the swing speed is limited by an orifice in the clamping port. Thus, uniform clamping of several swing clamps is also possible when oil supply is effected through a common bore.

Due to the sturdy swing mechanism the angle position of the clamping arm remains the same after a slight collision with the workpiece during loading or unloading. Also a collision during the clamping process is not critical.

#### Version without bottom cover

Focusing on a short length, the bottom cover had been omitted. The piston contacts the bottom of the cartridge-type hole.

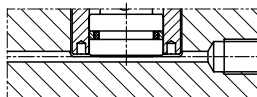

#### Swing direction

The units are available with clockwise and counterclockwise swing motion or without swing motion (0°).

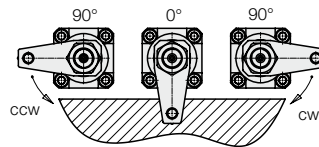

The swing angle can be limited by the insertion of distance plates (see page 2).

#### Wiper system

The standard FKM wiper has a high chemical resistance against most cooling and cutting fluids.

The optional metallic wiper protects the FKM wiper against mechanical damage due to big or hot swarf.

It consists of a radially floating wiping disk and a retaining disk.

The metallic wiper can be delivered already mounted ("M") or as an accessory for retrofitting (see page 4).

#### Attention!

The metallic wiper is not suitable for dry machining or minimum quantity lubrication. Also in applications with very little grinding swarf, the standard FKM wiper has a better protection effect.

If there is any danger that small particles stick to the piston rod, the metallic wiper disk can also be replaced by a hard plastic disk.

#### Position monitoring as accessory

Clamping arm complete with angle bracket (page 4).

Pneumatic position monitoring (page 5).

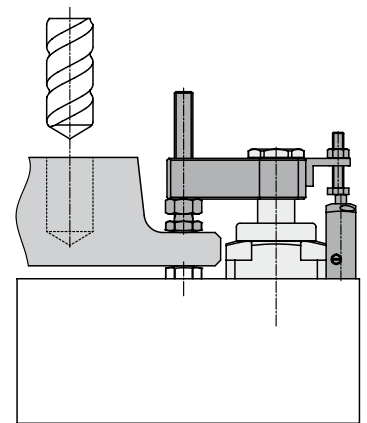

#### Important notes!

Swing clamps must only be used for clamping of workpieces in industrial applications and may only be operated with hydraulic oil.

They can generate very high forces. The workpiece, the fixture or the machine must be in the position to compensate these forces.

In the effective area of piston rod and clamping arm there is the danger of crushing.

The manufacturer of the fixture or the machine is obliged to provide effective protection devices.

The swing clamp has no overload protection device. When mounting the clamping arm, the clamping arm or the hexagon socket in the piston have to be backed up for tightening or untightening the fixing nut.

During loading and unloading of the fixture and during clamping a collision with the clamping arm has to be avoided.

Remedy: Mount position adaptor.

Operating conditions, tolerances and other data see data sheet A 0.100.

# Dimensions Accessories

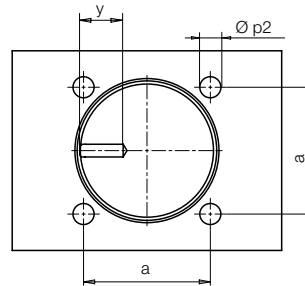
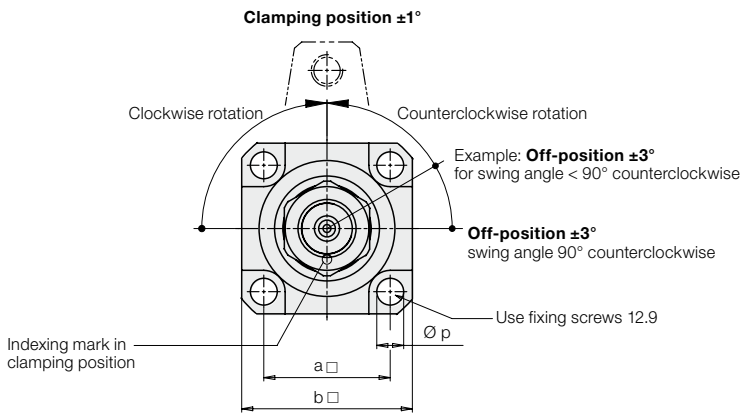
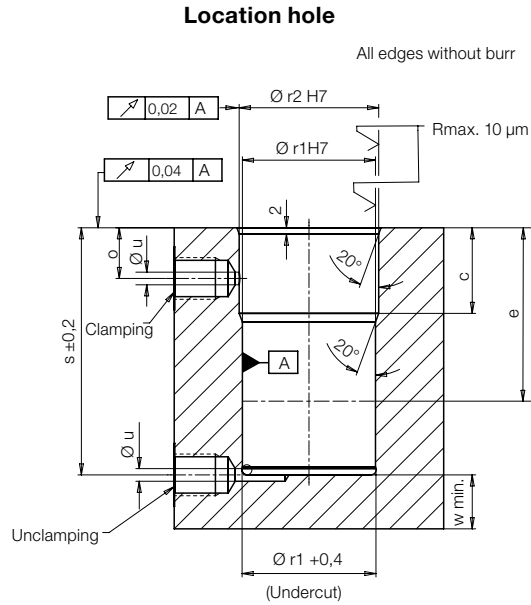
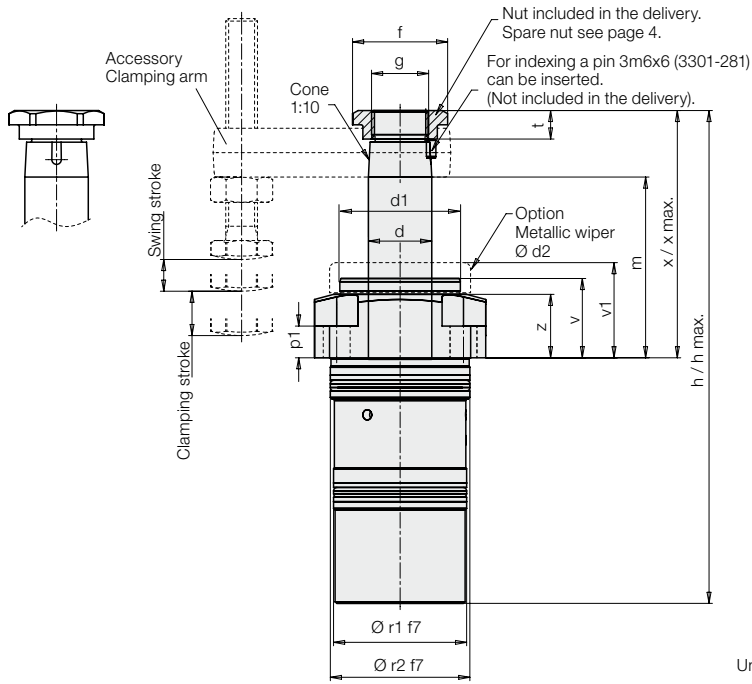

## Swing angle

### 1. Swing angle $90^\circ$ (standard)

|                | Part-no.             |
|----------------|----------------------|
| $90^\circ$ cw  | <b>184X-F090-RXX</b> |
| $90^\circ$ ccw | <b>184X-F090-LXX</b> |
| $0^\circ$      | <b>184X-F000-OXX</b> |

### 2. Swing angle $\alpha < 90^\circ$

$\alpha = 15^\circ$  to  $75^\circ$  in gradation of  $5^\circ$

By insertion of a distance plate the return stroke of the piston is reduced and thus the swing angle is reduced.

Clamping stroke and clamping position remain the same. The swing stroke and the dimensions  $h$ ,  $m$  and  $x$  are reduced by  $y$ :

$$y = (90^\circ - \alpha^\circ) * k \quad (k \text{ see chart page 3})$$

Example:

|                     |                      |
|---------------------|----------------------|
| Swing clamp         | 1845-F090-L30        |
| Desired swing angle | <b>45° ccw</b>       |
| <b>Part-no.</b>     | <b>1845-F045-L30</b> |

Shortening:

$$y = (90^\circ - \alpha^\circ) * 0.12 \text{ mm}/^\circ = 5.4 \text{ mm}$$

### 3. Swing angle $> 90^\circ$

Available on request!

## Technical characteristics

|                                    |                      |               |               |               |               |
|------------------------------------|----------------------|---------------|---------------|---------------|---------------|
| Max. pulling force                 | [kN]                 | 7.5           | 10.5          | 18.4          | 27.5          |
| Effective clamping force           | [kN]                 | see diagram   |               |               |               |
| Clamping stroke                    | [mm]                 | 12            | 12            | 15            | 15            |
| Swing stroke                       | [mm]                 | 11            | 12            | 15            | 21            |
| Total stroke +0.4/-0.3             | [mm]                 | 23            | 24            | 30            | 36            |
| Min. operating pressure            | [bar]                | 30            | 30            | 30            | 30            |
| Max. flow rate                     |                      |               |               |               |               |
| Clamping                           | [cm <sup>3</sup> /s] | 10            | 14            | 32            | 57            |
| Unclamping                         | [cm <sup>3</sup> /s] | 20            | 28            | 60            | 110           |
| Effective piston area              |                      |               |               |               |               |
| Clamping                           | [cm <sup>2</sup> ]   | 2.14          | 3.01          | 5.27          | 7.86          |
| Unclamping                         | [cm <sup>2</sup> ]   | 4.15          | 6.15          | 10.17         | 15.90         |
| Oil volume/stroke                  | [cm <sup>3</sup> ]   | 4.9           | 7.2           | 15.8          | 28.3          |
| Oil volume/return stroke           | [cm <sup>3</sup> ]   | 9.6           | 14.8          | 30.5          | 57.2          |
| Piston Ø                           | [mm]                 | 23            | 28            | 36            | 45            |
| a □                                | [mm]                 | 33            | 40            | 50            | 57            |
| b □                                | [mm]                 | 43            | 54            | 67            | 77            |
| c                                  | [mm]                 | 23            | 27            | 25            | 32            |
| Ø d                                | [mm]                 | 16            | 20            | 25            | 32            |
| Ø d1                               | [mm]                 | 28            | 38            | 45            | 48            |
| Ø d2                               | [mm]                 | 33            | 42            | 54            | 54.5          |
| e (fit depth)                      | [mm]                 | 45            | 50            | 53            | 53            |
| Ø f                                | [mm]                 | 27            | 30            | 36            | 40            |
| g                                  |                      | M14 x 1.5     | M18 x 1.5     | M20 x 1.5     | M28 x 1.5     |
| h +0.4/-0.5 / h max. <sup>1)</sup> | [mm]                 | 150.5 / 151.8 | 161.5 / 163.3 | 188.5 / 190.3 | 216.9 / 217.4 |
| k                                  | [mm/°]               | 0.091         | 0.093         | 0.12          | 0.152         |
| m +0.4/-0.7 <sup>2)</sup>          | [mm]                 | 56.4          | 57.9          | 68.9          | 78.3          |
| o                                  | [mm]                 | 16            | 16            | 20            | 25            |
| Ø p                                | [mm]                 | 6.6           | 8.5           | 10.5          | 13.0          |
| p1                                 | [mm]                 | 13            | 10            | 14            | 16            |
| Ø p2                               |                      | M6            | M8            | M10           | M12           |
| Ø r1                               | [mm]                 | 35            | 42            | 52            | 63            |
| Ø r2                               | [mm]                 | 36            | 44            | 55            | 65            |
| s ±0.2                             | [mm]                 | 73            | 78            | 89            | 101           |
| t                                  | [mm]                 | 7.5           | 9             | 10            | 10            |
| Ø u max.                           | [mm]                 | 4             | 4             | 4             | 4             |
| v                                  | [mm]                 | 25            | 25            | 29            | 34            |
| v1 metallic wiper                  | [mm]                 | 30            | 30            | 34            | 39            |
| w min. [thickness of the bottom]   | [mm]                 | 14            | 16            | 16            | 20            |
| x +0.3/-0.2 / x max. <sup>1)</sup> | [mm]                 | 78 / 79.2     | 84 / 85.8     | 100 / 101.6   | 116.5 / 116.8 |
| y min.                             | [mm]                 | 8             | 9             | 10            | 12            |
| z                                  | [mm]                 | 20            | 20            | 24.4          | 28.4          |
| Weight, approx.                    | [kg]                 | 0.9           | 1.4           | 2.3           | 3.65          |

### Part-no.

|                               |                       |                       |                       |                       |
|-------------------------------|-----------------------|-----------------------|-----------------------|-----------------------|
| Clockwise rotation 90°        | <b>1843-F090-R23M</b> | <b>1844-F090-R24M</b> | <b>1845-F090-R30M</b> | <b>1846-F090-R36M</b> |
| Counterclockwise rotation 90° | <b>1843-F090-L23M</b> | <b>1844-F090-L24M</b> | <b>1845-F090-L30M</b> | <b>1846-F090-L36M</b> |
| 0 degree                      | <b>1843-F000-023M</b> | <b>1844-F000-024M</b> | <b>1845-F000-030M</b> | <b>1846-F000-036M</b> |

<sup>1)</sup> h / x = upper edge piston    h max. / x max. = upper edge nut

<sup>2)</sup> m = lower edge clamping arm

**M** = Option metallic wiper (see also page 1)

### Effective clamping force with accessory clamping arm as a function of the oil pressure

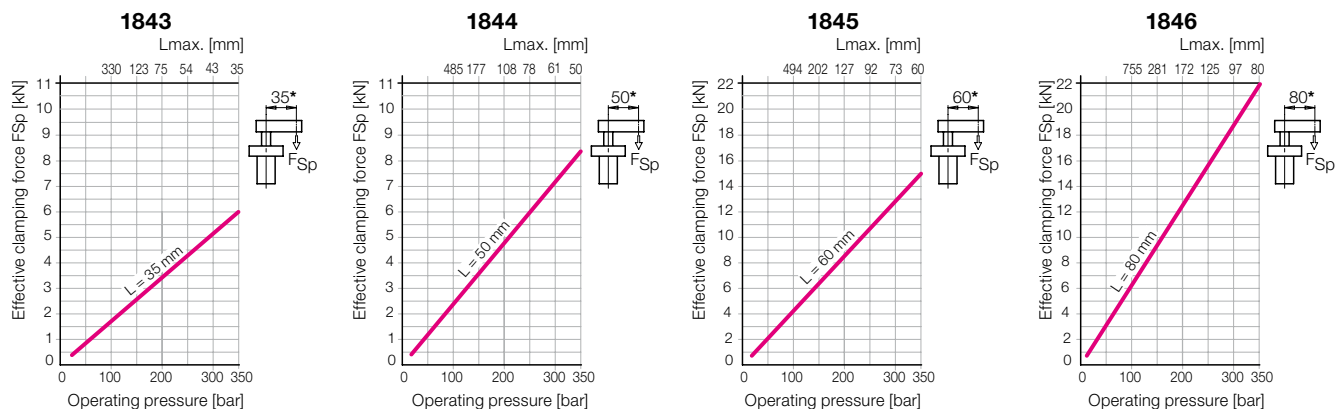

\* Clamping force for other lengths see page 4.

# Accessories - Clamping arms • Metallic wipers

## Calculation of the flow rate • Calculation of the clamping force

### Clamping arm, max. 350 bar

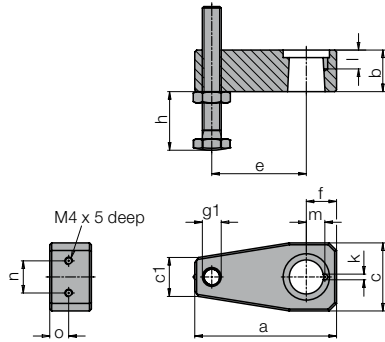

### Clamping arm complete with angle

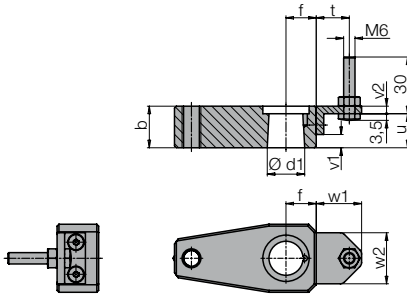

### Special clamping arm

#### 1. Connecting dimensions

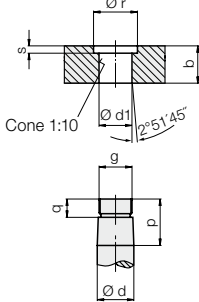

#### 2. Admissible flow rate Q\*

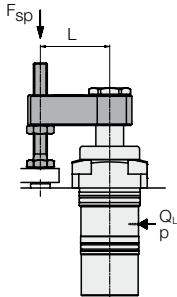

In the chart on page 3, the admissible flow rates for clamping and unclamping with the clamping arms (accessories) are specified. Longer special clamping arms have a higher torque of inertia. To avoid an overload of the swing mechanism, the flow rate has to be reduced:

#### 2.1 Moments of inertia are known

$$Q_L = Q_e \cdot \sqrt{\frac{J_e}{J_L}} \text{ cm}^3/\text{s}$$

$Q_L$  = Flow rate with special clamping arm

$Q_e$  = Flow rate as per chart (page 3)

$J_e$  = Moment of inertia of the clamping arm (accessory) with contact bolt (chart)

$J_L$  = Moment of inertia special clamping arm

\* Only for vertical mounting position!

### Swing clamps

|                | 1843    | 1844    | 1845    | 1846    |
|----------------|---------|---------|---------|---------|
| a              | 58      | 75      | 93      | 120     |
| b              | 17      | 22      | 26      | 32      |
| c              | 28      | 36      | 45      | 60      |
| c1             | 14      | 20      | 23      | 28      |
| Ød f7          | 16      | 20      | 25      | 32      |
| Ød1 +0.1/+0.05 | 15.8    | 19.8    | 24.8    | 31.8    |
| e              | 35      | 50      | 60      | 80      |
| f              | 16      | 16      | 22      | 26      |
| g              | M14x1.5 | M18x1.5 | M20x1.5 | M28x1.5 |
| g1             | M8      | M10     | M12     | M16     |
| h min/max      | 5/45    | 6/64    | 7/70    | 9/85    |
| Ø k +0.1       | 3       | 3       | 3       | 3       |
| l +0.5         | 9       | 10      | 10      | 10.5    |
| m ±0.05        | 7.8     | 9.8     | 12      | 15      |
| n              | 11      | 17      | 20      | 20      |
| o              | 6       | 10      | 12      | 20      |
| p              | 22.5    | 27      | 32      | 39      |
| q              | 9       | 10      | 11      | 12.7    |
| Ø r            | 20      | 24.5    | 31      | 34.5    |
| s              | 2.5     | 4       | 4       | 4.5     |
| t              | 11      | 17.5    | 19      | 19      |
| u              | 17      | 18      | 21      | 19      |
| v1             | 6       | 7       | 8       | 6       |
| v2             | 4       | 4       | 5       | 5       |
| w1             | 18      | 24      | 26      | 26      |
| w2             | 21      | 27      | 30      | 30      |

#### Part-no. clamping arm

|  | 0354-152 | 0354-153 | 0354-154 | 0354-155 |
|--|----------|----------|----------|----------|
| - with contact bolt                            |          |          |          |          |
| Weight, approx. [kg]                           | 0.19     | 0.39     | 0.69     | 1.43     |
| Moment of inertia of $J_e$ [kgm <sup>2</sup> ] | 0.00011  | 0.00046  | 0.0011   | 0.00398  |
| - without thread g1                            |          |          |          |          |
| Weight, approx. [kg]                           | 0.16     | 0.34     | 0.62     | 1.28     |
| Moment of inertia of $J_e$ [kgm <sup>2</sup> ] | 0.00007  | 0.00033  | 0.00084  | 0.00298  |
| - complete with angle                          |          |          |          |          |
| Angle bracket complete                         | 0184-003 | 0184-004 | 0184-005 | 0184-005 |
| Metallic wiper                                 | 0341-104 | 0341-107 | 0341-105 | 0341-100 |
| Spare nut                                      | 3527-092 | 3527-014 | 3527-099 | 3527-015 |
| Tightening torque [Nm]                         | 16       | 30       | 42       | 90       |

### Special clamping arm

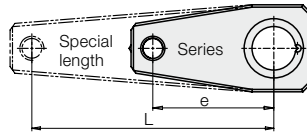

#### 2.2 Moments of inertia not known

This simplified calculation is only applicable for clamping arms of the above shape.

**Example:** Swing clamps 1843

$L = 70 \text{ mm}$

$e = 35 \text{ mm}$  as per above chart

$Q_e = 10 \text{ cm}^3/\text{s}$  (as per chart page 3)

- Extension factor  $x = \frac{L}{e} = \frac{70 \text{ mm}}{35 \text{ mm}} = 2$
- Flow rate factor as per diagram  $\rightarrow y = 0.35$
- Max. flow rate  $Q_L = y \cdot Q_e = 0.35 \cdot 10 \text{ cm}^3/\text{s} = 3.5 \text{ cm}^3/\text{s}$
- Min. clamping time as per diagram  $\rightarrow$  approx. 1.4 s

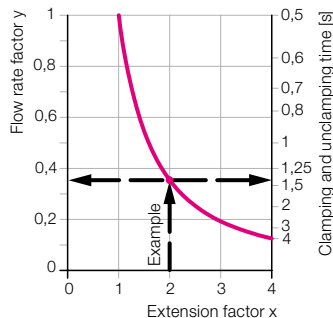

Adm. flow rate and clamping time as a function of the clamping arm extension

#### Clamping force and admissible operating pressure

Effective clamping force (general)

$$F_{Sp} = \frac{p}{A + (B \cdot L)} \leq F_{adm.} \quad [\text{kN}]$$

Admissible clamping force

$$F_{adm} = \frac{C}{L} \quad [\text{kN}]$$

Admissible operating pressure

$$p_{adm} = \frac{D}{L} + E \leq 350 \quad [\text{bar}]$$

$L$  = special length [mm]  $p$  = pressure [bar]

$A, B, C, D, E$  = constants as per chart

| Constant | 1843  | 1844  | 1845  | 1846  |
|----------|-------|-------|-------|-------|
| A        | 46.64 | 33.15 | 18.98 | 12.72 |
| B        | 0.335 | 0.17  | 0.073 | 0.04  |
| C        | 210   | 420   | 900   | 1760  |
| D        | 9795  | 13926 | 17078 | 22386 |
| E        | 70.26 | 71.33 | 65.44 | 70.36 |

**Example:** Swing clamps 1843

$L = 70 \text{ mm}$

1. Admissible clamping force

$$F_{adm} = \frac{C}{L} = \frac{210}{70} = 3 \text{ kN}$$

2. Admissible operating pressure

$$p_{adm} = \frac{D}{L} + E = \frac{9795}{70} + 70.26 = 210 \text{ bar}$$



**Application**

The pneumatic position monitoring signals the following conditions by closing two bore holes:

*Clamping arm in clamping position and piston in clamping area*

By the pressure increase in the pneumatic line an electro-pneumatic pressure switch or a differential pressure switch can be actuated. These electrical switching devices are integrated in the electric control so that on the clamping fixture no electricity is required.

**Description**

The control bolt is fitted with small clearance into the housing and is maintained by spring force in the off-position. All components are made of stainless steel. The pneumatic is preferably supplied and removed through drilled channels; this offers an optimum swarf protection. Optionally, also pneumatic hoses NW2 can be connected.

**Technical characteristics**

|                             |                     |
|-----------------------------|---------------------|
| Connection                  | O-ring or thread M3 |
| Nominal diameter            | [mm] 2              |
| Max. air pressure           | [bar] 10            |
| Range of operating pressure | [bar] 3...5         |
| Differential pressure *) at |                     |
| 3 bar system pressure       | [bar] min. 1.5      |
| 5 bar system pressure       | [bar] min. 3        |
| Air flow rate **)           | [l/min] 10...20     |
| Actuating force ***)        | [N/bar] 2.8         |
| + Spring force              | [N] 6.5...13        |
| Plunger stroke              | [mm] max. 10        |

\*) Pressure drop when controlling the function "Clamped", if one or several position monitorings are not operated.

\*\*) For measuring the air flow rate appropriate devices are available. Please contact us.

\*\*\*) Port A closed.

E = Input  
A = Output

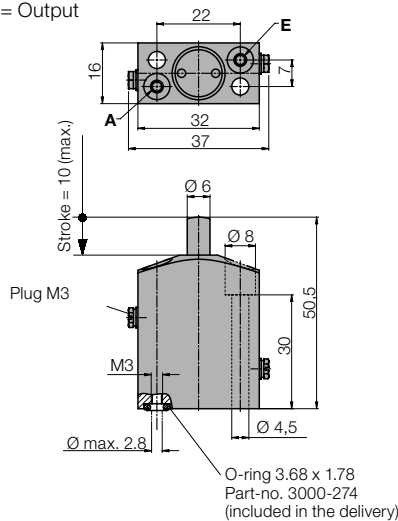

**Mounting example**

Attention!  
Piston extended (unclamped) but clamping arm shown in clamping position.

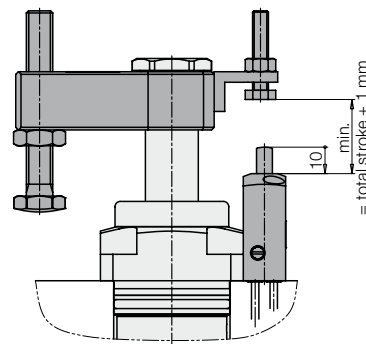

**Connecting scheme**

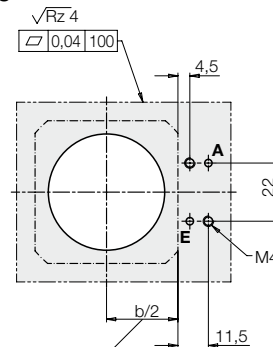

2 connecting bores max. Ø 2.8

**Pneumatic port**

**Drilled channels**

The position monitoring is fixed to the above connecting scheme with inserted O-rings. With the indicated distance dimensions the position monitoring is directly located at the flange of the swing clamp and has thus the correct distance for the operation of the clamping arm.

**Hose connection**

Remove the plugs M3 and screw-in the insertion nipple fitting M5 (accessory). The O-rings remain inserted for sealing at the flange-mounting surface.

**Important notes**

When adjusting the control cam it has to be considered that the control bolt will only be operated after completion of the swing stroke. Within the clamping range the control bolt should have a stroke reserve of approx. 1 mm also for idle strokes (without workpiece) to avoid mechanical damage.

**Throttling of the flow rate**

A flow rate throttling always has to be effected in the supply line to the swing clamp. This avoids a pressure intensification and thereby pressures exceeding 350 bar.

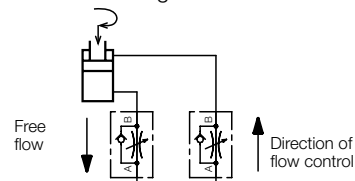

**Monitoring by pneumatic pressure switch**

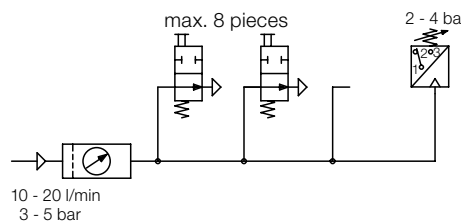

For the evaluation of the pressure built-up standard electro-pneumatic pressure switches can be used. It is possible to monitor up to 8 position monitorings connected in series (see circuit diagram).

Please note!

Functioning of the pneumatic position monitorings is only process-safe, if the air quantity and the system pressure are throttled. The nominal values are indicated below technical characteristics.

**Switching area 2 ÷ 9 mm**

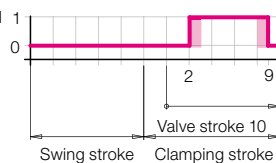

Part-no. 0353-921

**Switching area 2 ÷ 10 mm**

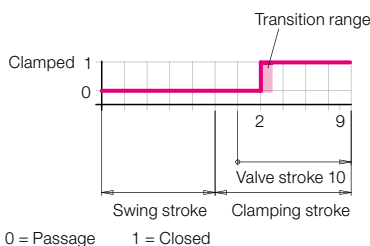

Part-no. 0353-937

**Accessories**

Insertion nipple fitting M3

Part-no.

3890-188