

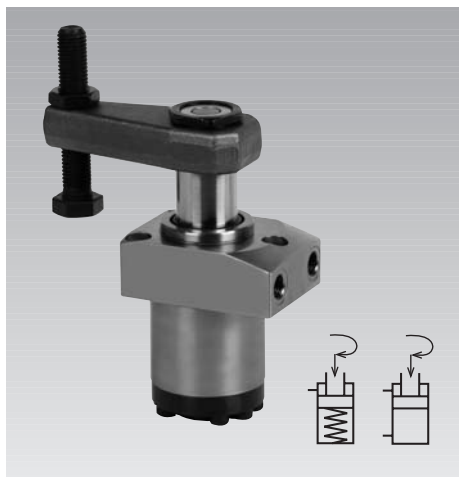

Swing Clamps with Overload Protection Device

top flange, single and double acting,
 max. operating pressure 500 bar



Hydraulic connecting possibilities

Pipe thread

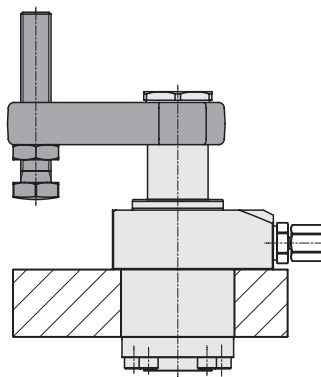

Manifold mounting with O-ring sealing

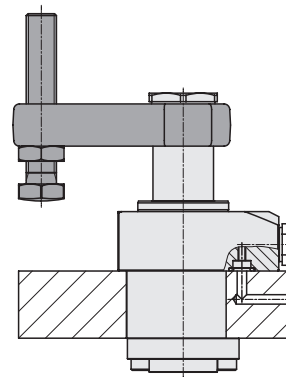

Application

Hydraulic swing clamps are used for clamping of workpieces when it is essential to keep the clamping area free of straps and clamping components for unrestricted workpiece loading and unloading.

Function

This hydraulic clamping element is a pull-type cylinder where a part of the total stroke is used to swing the piston.

Swing direction

The units are available with clockwise and counterclockwise swing motion or without swing motion (0°). Starting from the off-position.

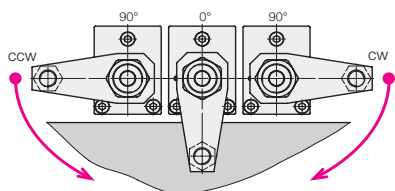

Standard swing angles are 45°, 60°, and 90° ±2°.

Special angles on request.

Other variants, as e.g. versions with metallic wiper on request.

0°-Version

Use as pure pull-type cylinder with a piston which is secured against torsion and which allows eccentric load as per clamping force diagram.

Application example

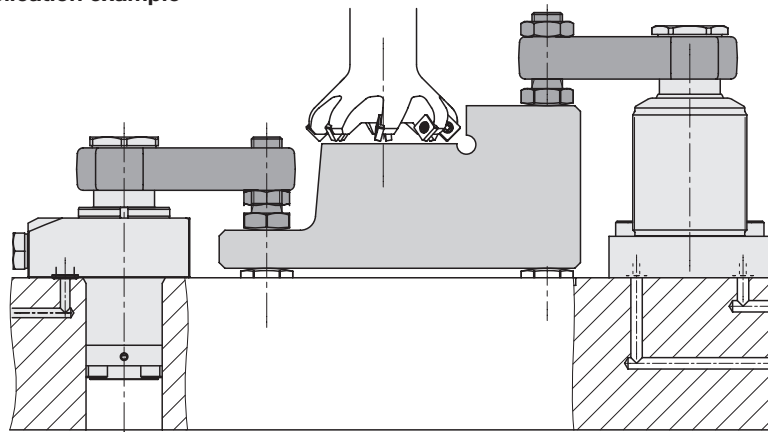

Overload protection device

An integrated mechanical overload protection device prevents damage to the swing mechanism when striking an object within the 90° rotation, clamping or unclamping alike, or in case of incorrect mounting of the clamping arm.

Metallic wiper optional

Material

By nitrating wear is reduced and protection against corrosion increased.

Piston material:	High alloy steel
Cylinder body:	High alloy steel
Seals:	NBR
Wiper:	FKM

Option: metallic wiper

These swing clamps are also delivered with mounted metallic wiper that protect the subjacent FKM wiper against swarf (see page 2 and 3).

Note!

Operating conditions, tolerances and other data see data sheet A 0.100.

When using single-acting swing clamps, it is absolutely necessary to follow the instructions for venting of the spring area on data sheet A 0.110.

Further notes see Page 3.

Dimensions Technical Data

Accessory:
Clamping arm
assembly, complete
for max. 200 bar

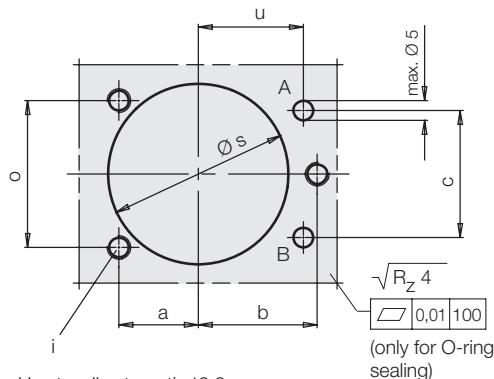
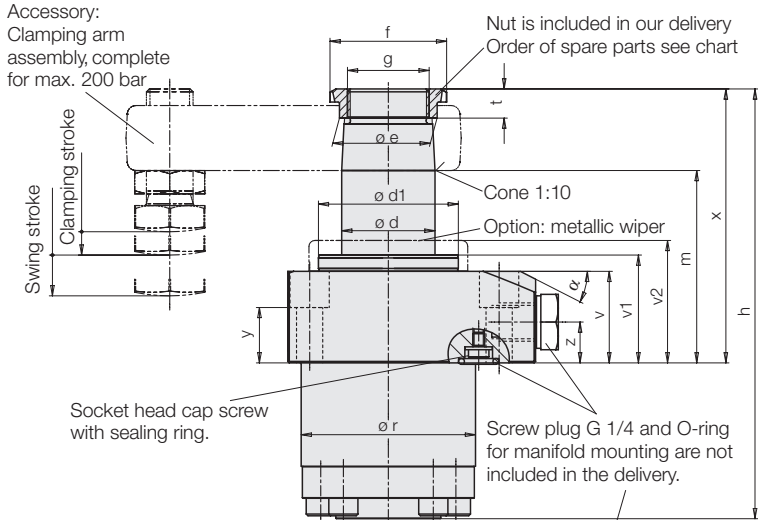

A: Clamping
B: Venting (single acting)
B: Unclamping (double acting)

The swing clamps will be delivered ready for the connection of pipes.

Manifold mounting (drilled channels)

Single acting

Screw in 1 screw plug G 1/4 (part-no. 3610-006) in port A and remove socket head cap screw with sealing ring. Insert 1 O-ring 10x2 (part-no. 3000-347) in the counterbore.

If venting of the spring area at port B shall also be effected through drilled channels: Replace screw plug with air filter by screw plug G 1/4. Remove socket head cap screw with sealing ring and insert O-ring 10x2 (part-no. 3000-347) in counterbore.

Double acting

Screw in 2 plugs G 1/4 (part-no. 3610-006).
Remove 2 socket head cap screws with sealing ring.
Insert 2 O-rings 10x2 (part-no. 3000-347) in the counterbore.

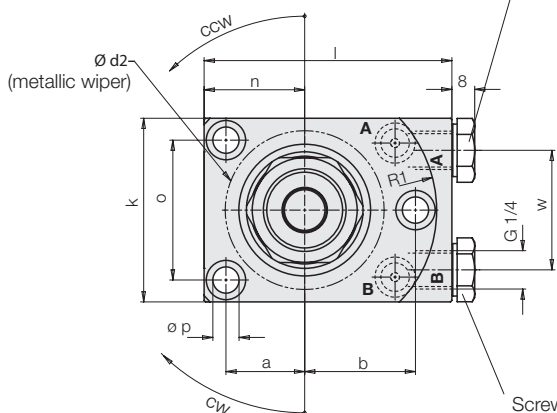

Effective clamping force F_{Sp} as function of operating pressure p

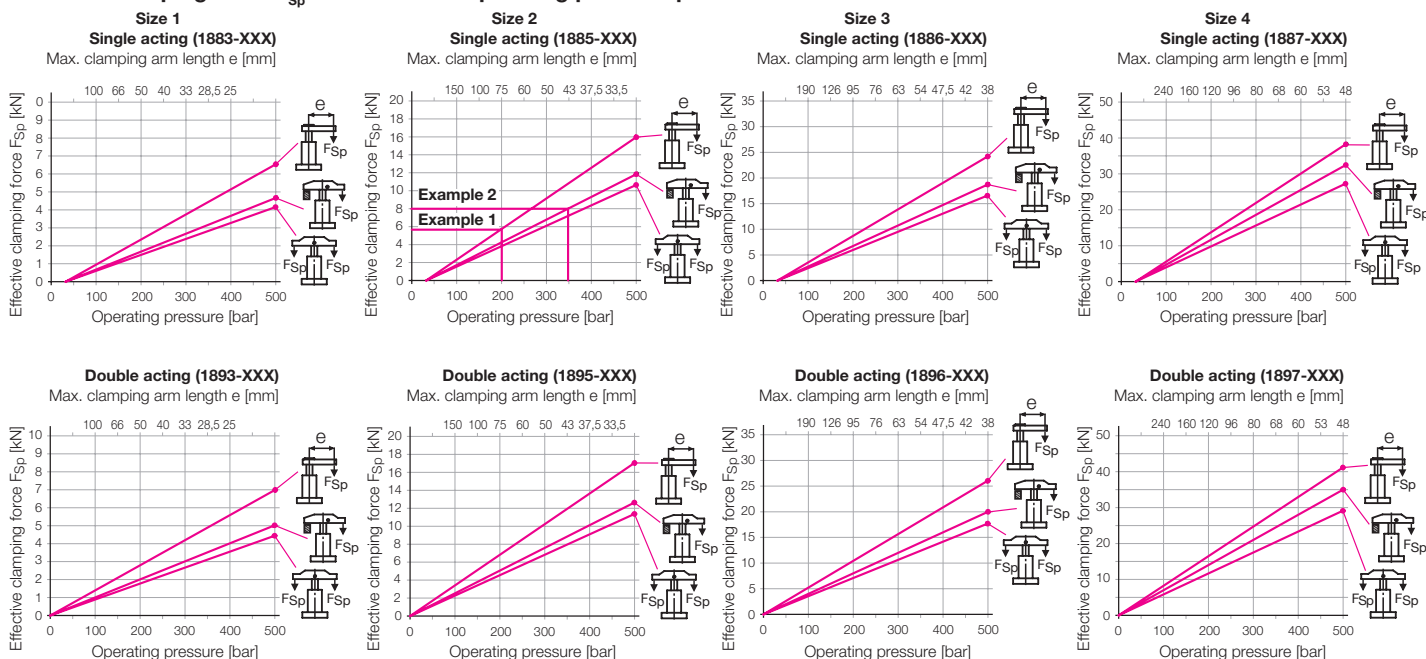

Note:

The clamping force of single-acting swing clamps is reduced by the opposite-directed spring return force. For this reason the clamping force is slightly lower than that of double-acting swing clamps.

Example 1: 1885-103 single acting. An operating pressure p of 200 bar in connection with standard clamping arm 0354-003 of max. arm length L = 75 mm results in an effective clamping force F_{Sp} of 5.8 kN.

Example 2: 1885-103 single acting. For a desired effective clamping force F_{Sp} of 8 kN and use of a swing clamp 1885-103 with a standard clamping strap 0354-002 an operating pressure p of 345 bar is required.

Dimensions Technical Data

	Size 1			Size 2			Size 3			Size 4		
Clamping stroke [mm]	11	25	50	14	25	50	15	25	50	15	25	50
Swing stroke [mm]	7	9	9	8	10	10	11	11	11	9	12	12
Total stroke [mm]	18	34	59	22	35	60	26	36	61	24	37	62
Operating pressure to swing min. [bar]	30	30	30	30	30	30	30	30	30	30	30	30
Max. oil flow rate [cm ³ /s]	3,2	3,2	3,2	10	10	10	18,4	18,4	18,4	27,7	27,7	27,7
Oil volume / stroke [cm ³]	3,2	6	10,5	10	16	27,2	18,4	25,5	43,2	27,7	43	72
Oil volume /return stroke [cm ³]	8,8	17	29	27,7	44	76	51	71	120	75	116	194
α [°]	12	12	12	27	27	27	26	26	26	25	25	25
a [mm]	20	20	20	27	27	27	37	37	37	42	42	42
b [mm]	30	30	30	38	38	38	50	50	50	55	55	55
c [mm]	32	32	32	46	46	46	62	62	62	75	75	75
\emptyset d [mm]	20	20	20	32	32	32	40	40	40	50	50	50
\emptyset d1 [mm]	38	38	38	48	48	48	60	60	60	70	70	70
\emptyset d2 [mm]	42	42	42	54,5	54,5	54,5	75	75	75	87	87	87
\emptyset e [mm]	23,5	23,5	23,5	33,5	33,5	33,5	45	45	45	55,5	55,5	55,5
f [mm]	30	30	30	40	40	40	55	55	55	68	68	68
g [mm]	M 18x1,5	M 18x1,5	M 18x1,5	M 28x1,5	M 28x1,5	M 28x1,5	M 35x1,5	M 35x1,5	M 35x1,5	M 45x1,5	M 45x1,5	M 45x1,5
h [mm]	126,5	158,5	208,5	147,5	173,5	223,5	172	192	242	182	208	258
i [mm]	M6	M6	M6	M8	M8	M8	M10	M10	M10	M12	M12	M12
k [mm]	50	50	50	63	63	63	85	85	85	95	95	95
l [mm]	70	70	70	85	85	85	110	110	110	125	125	125
m -1 [mm]	57	73	98	66	79	104	70	80	105	69	82	107
n [mm]	26,5	26,5	26,5	34,5	34,5	34,5	47	47	47	55	55	55
o [mm]	37	37	37	48	48	48	65	65	65	72	72	72
\emptyset p [mm]	6,6	6,6	6,6	9	9	9	11	11	11	14	14	14
\emptyset r \pm 0,1 [mm]	44,8	44,8	44,8	59,8	59,8	59,8	79,8	79,8	79,8	89,8	89,8	89,8
R1 [mm]	36	36	36	45,3	45,3	45,3	59,5	59,5	59,5	66	66	66
\emptyset s +1 [mm]	45	45	45	60	60	60	80	80	80	90	90	90
t [mm]	9	9	9	10	10	10	11	11	11	12	12	12
u [mm]	26,5	26,5	26,5	31	31	31	40	40	40	45	45	45
v [mm]	26,4	26,4	26,4	31,4	31,4	31,4	29,4	29,4	29,4	29,4	29,4	29,4
v1 [mm]	31	31	31	37	37	37	35	35	35	35	35	35
v2 [mm]	36	36	36	42	42	42	40	40	40	40	40	40
w [mm]	28	28	28	41	41	41	55	55	55	70	70	70
x [mm]	78	94	119	94	107	132	104	114	139	109	122	147
y [mm]	18	18	18	19	19	19	15	15	15	14	14	14
z [mm]	14	14	14	14	14	14	12	12	12	12	12	12
Declutch moment of overload protection [Nm]	3,5	3,5	3,5	11	11	11	17	17	17	22/30**	22/30**	22/30**

Single acting 90°

Part-no.

Swing direction cw	1883-103	1885-103	1886-103	1887-103
Swing direction ccw	1883-203	1885-203	1886-203	1887-203
0-degree	1883-243	1885-243	1886-243	1887-243

Double acting 90°

Part-no

Swing direction cw	1893-103	1893-303	1893-503	1895-103	1895-303	1895-503	1896-103	1896-303	1896-503	1897-103	1897-303	1897-503
Swing direction ccw	1893-203	1893-403	1893-603	1895-203	1895-403	1895-603	1896-203	1896-403	1896-603	1897-203	1897-403	1897-603
0-degree	1893-243	1893-443	1893-643	1895-243	1895-443	1895-643	1896-243	1896-443	1896-643	1897-243	1897-443	1897-643
Metallic wiper complete (spare part)	0341-107			0341-100			0341-101			0341-102		
Spare nut	3527-014			3527-015			3527-048			3527-016		

** single acting/double acting

Code numbers for available swing angles

Swing angles	Part-no.
90°	18XX-X0X
60°	18XX-X2X
45°	18XX-X3X

Part-no.
Spare O-ring 10x2 3000-347
Plug G 1/4 3610-006

Option metallic wiper
for double-acting swing clamps
Part-no.: 189X-XXXM

Important notes

1. Danger of injury

Hydraulic clamping elements can generate considerable forces. Due to the 90° swing motion, the exact clamping and unclamping position cannot be determined in advance. Considerable injuries can be caused to fingers in the effective area of the clamping arm. Remedy: protection device with electrical locking.

2. Admissible oil flow rate

In case of the admissible oil flow rate as per table the shortest possible clamping time is 1 second. If the flow rate of the pump divided by the number of swing clamps is higher than the indicated value in the chart, the flow rate has to be throttled to avoid any overload and thereby high wear. Throttling has to be made in the oil supply line to the swing clamp to rule out a possible pressure intensification. Use only flow control valves which allow oil return from the swing clamp without any impediments.

3. Unimpeded swing motion

The swing motion must not be impeded and the clamping arm may only contact the workpiece after completion of the swing stroke.

4. Clamping arm assembly

When tightening and untightening the fixing screw, the clamping arm has to be backed up to avoid the introduction of moments to the piston rod.

5. Adjustment of contact bolt

The contact bolt may only contact the workpiece after completion of the swing motion. When tightening and untightening the fixing screw, the clamping arm has to be backed up (see 4.).

6. Special clamping arms

When using special clamping arms with other lengths, the corresponding operating pressures as shown in the clamping force diagram must not be exceeded. If longer clamping arms will be used, not only the operating pressure but also the flow rate have to be reduced (see 2.).

7. Venting of spring area

The spring area of single-acting swing clamps has to be vented to avoid function problems. A sintered metal air filter avoids penetration of contaminants. If there is a possibility that cutting lubricants and coolants penetrate through the sintered metal air filter into the cylinder's interior, a vent hose has to be connected and be placed in a protected position (see data sheet A 0.110).

8. Bleeding

Air in the oil prolongs the clamping time considerably and leads to function troubles. Therefore bleeding has to be effected during start up.

8.1 Pipe thread

Loosen carefully the union nut of the pipe at low oil pressure and pump until bubblefree oil comes out. Retighten the union nut.

8.2 Flange with O-ring sealing for manifold mounting

Loosen carefully the plug G 1/4 at low oil pressure and pump until bubblefree oil comes out. Retighten the plug.

Accessories

Dimensions for special clamping arms



Swing clamp	a	b	Øc	Ød ^{+0.10 +0.05}	e	f	g	Øh _{f7}
18X3-XXX	16	4	24	19.8	10	21	M 18x1.5	20
18X5-XXX	23	5	34	31.8	12	28	M 28x1.5	32
18X6-XXX	28	5	46	39.8	12	34	M 35x1.5	40
18X7-XXX	34	6	56	49.8	13	40	M 45x1.5	50

Clamping arm, max. 300 bar

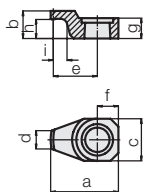

Swing clamp	a	b	c	d	e	f	g	h	i	Weight [kg]	Part-no.
18X3-XXX	51.5	21	32	14	33.5	16	15.5	14.5	7	0.11	3548-238
18X5-XXX	76	28	46	25	50	23	22.5	19	7	0.3	3548-236
18X6-XXX	100	34	66	39	64	33	28	23	7	0.84	3548-301
18X7-XXX	123	40	75	39	82.5	37.5	34	27	8	1.3	3548-302

Material: 42CrMo4

Clamping arm assembly, complete, max. 200 bar

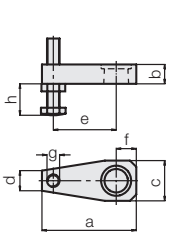

Swing clamp	a	b	c	d	e	f	g	h max.	h min.	Weight [kg]	Part-no.
18X3-XXX	75	16	32	16	50	16	M10	64	6	0.2	0354-001
18X5-XXX	115	23	48	22	75	25	M16	79	9	0.7	0354-003
18X6-XXX	140	28	60	28	95	30	M16	79	9	2.0	0354-042
18X7-XXX	178	34	78	40	120	40	M20	98	12	2.55	0354-005

Swing clamp	a	b	c	d	f	Weight [kg]	Part-no.
18X3-XXX	75	16	32	16	16	0.18	3921-016
18X5-XXX	115	23	48	22	25	0.65	3921-017
18X6-XXX	140	28	60	28	30	1.85	3921-021
18X7-XXX	178	34	78	40	40	2.3	3921-018

Material: 42CrMo4

Clamping strap assembly, complete, with carrier, max. 500 bar

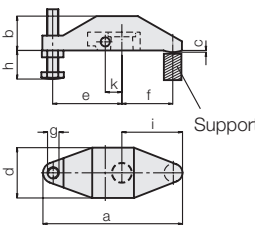

Swing clamp	a	b	c	d	e	f	g	h max.	h min.	i	k	Weight [kg]	Part-no.
18X3-XXX	122	30	1.5	44	60	45	M10	64	6	53	14.5	0.57	0354-000
18X5-XXX	185	45	2	58.5	83	75	M16	79	9	87	21	1.58	0354-002
18X6-XXX	203	54	2.5	82	92	82	M16	79	9	95	28	3.45	0354-041
18X7-XXX	223	59	2.5	98	100	90	M20	98	12	105	33	4.75	0354-004

Material: GGG-40

Carrier for special clamping strap

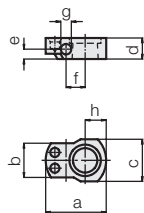

Swing clamp	a	b	c	d	e	f	g ^{H7}	h	Weight [kg]	Part-no.
18X3-XXX	46	26	32	16	7.5	14.5	8	16	0.08	3542-093
18X5-XXX	59	32	40	23	13	21	10	22	0.16	3542-094
18X6-XXX	82	44.5	58	28	17	28	12	34	0.5	3542-132
18X7-XXX	90	56	68	34	21	33	14	36	0.65	3542-096

Material: C 45

Double clamping arm assembly, complete, with carrier, max. 500 bar

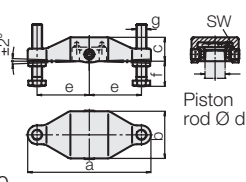

Swing clamp	a	b	c	Ød	e	f min.	f max.	g	SW	Weight [kg]	Part-no.
18X3-XXX	138	59	28.5	20	60	10	64	M 10	5	0.83	0354-131
18X5-XXX	196	75	38	32	83	15	79	M 16	8	2.11	0354-132
18X6-XXX	216	85	47	40	92	15	79	M 16	8	3.17	0354-133
18X7-XXX	236	105	56	50	100	19	98	M 20	8	5.24	0354-134

Material: GGG-40

Carrier, complete with threaded bolt and spring clamping elements

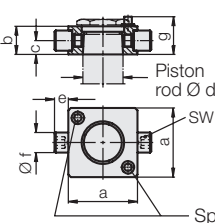

Swing clamp	a ^{±0.1}	b	c	Ød	e	Øf ⁶	g*	SW	Part-no.
18X3-XXX	43	16	7.5	20	9	10	21.5	5	0354-141
18X5-XXX	55	23	11	32	11	16	29	8	0354-142
18X6-XXX	63	28	15	40	12	18	35	8	0354-143
18X7-XXX	77	34	17	50	15	20	41	8	0354-144

* Stop surface for spring elements

Material: C 45