

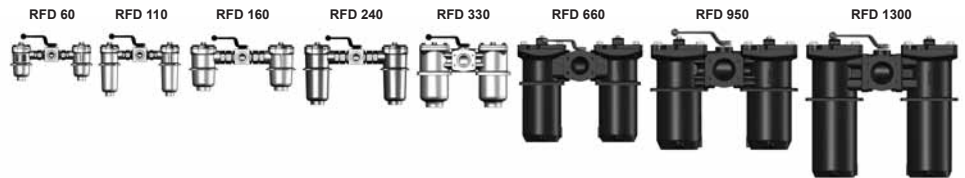

Change-Over Return Line Filter RFD

up to 1300 l/min, up to 25 bar



1. TECHNICAL SPECIFICATIONS

1.1 FILTER HOUSING

Construction

The filter housings are designed in accordance with international regulations. They consist of one-piece housings with bolt-on cover plates. The two housings are connected by a ball change-over valve with negative overlap and single-lever operation.

Standard equipment:

- bypass valve
- connection for a clogging indicator (1 clogging indicator per filter side!)

1.2 FILTER ELEMENTS

HYDAC filter elements are validated and their quality is constantly monitored according to the following standards:

- ISO 2941
- ISO 2942
- ISO 2943
- ISO 3724
- ISO 3968
- ISO 11170
- ISO 16889

Contamination retention capacities in g

RFD	Elements	Betamicon® (BN4HC)			
		3 µm	5 µm	10 µm	20 µm
60	1x0060R	5.7	6.3	7.6	8.6
110	1x0110R	12.0	13.3	16.0	18.1
160	1x0160R	18.6	20.7	24.9	28.1
240	1x0240R	29.3	32.5	39.1	44.2
330	1x0330R	38.4	42.6	51.2	57.9
660	1x0660R	87.1	96.5	116.1	131.3
950	1x0950R	130.0	144.1	173.3	196.1
1300	1x1300R	181.0	200.7	241.4	273.1

Filter elements are available with the following pressure stability values:

Betamicon® (BN4HC):	20 bar
Paper (P/HC):	10 bar
Stainl. steel wire mesh (W/HC):	20 bar
Stainless steel fibre (V):	210 bar
Betamicon®/Aquamicron® (BN4AM):	10 bar
Aquamicron® (AM):	10 bar

1.3 FILTER SPECIFICATIONS

Nominal pressure	25 bar
Temperature range	-10 °C to +100 °C
Material of filter housing and cover plate	RFD 60 to 330: Aluminium RFD 660 to 1300: EN-GJS-400-15
Type of clogging indicator	VR Connection thread G ½ (return line indicator up to 25 bar operating pressure)
Pressure setting of the clogging indicator	2 bar (others on request)
Bypass cracking pressure	3 bar (others on request)

1.4 SEALS

NBR (= Perbunan)

1.5 INSTALLATION

Tank-top filter

1.6 SPECIAL MODELS AND ACCESSORIES

On request

1.7 SPARE PARTS

See Original Spare Parts List

1.8 CERTIFICATES AND APPROVALS

On request

1.9 COMPATIBILITY WITH HYDRAULIC FLUIDS ISO 2943

- Hydraulic oils H to HLPD DIN 51524
- Lubrication oils DIN 51517, API, ACEA, DIN 51515, ISO 6743
- Compressor oils DIN 51506
- Biodegradable operating fluids VDMA 24568 HETG, HEES, HEPG
- Fire-resistant fluids HFA, HFB, HFC and HFD
- Operating fluids with high water content (>50% water content) and CLP oils on request

1.10 IMPORTANT INFORMATION

- Filter housings must be earthed.
- When using electrical clogging indicators, the electrical power supply to the system must be switched off before removing the clogging indicator connector.
- Filters must be flexibly mounted and not fixed rigidly to the floor or used as a pipe support.

Symbol for hydraulic systems

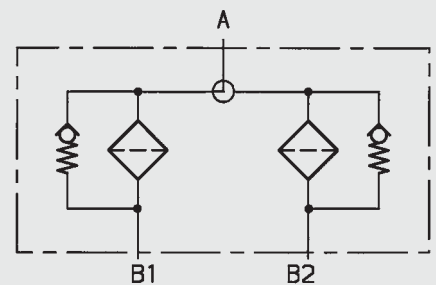

2. MODEL CODE (also order example)

RFD BN/HC 330 D A L 10 D 1 . X /-L24

2.1 COMPLETE FILTER

Filter type _____

RFD

Filter material of element _____

BN/HC Betamicon® (BN4HC) W/HC Stainless steel wire mesh
 V Stainless steel fibre AM Aquamicon®
 P/HC Paper BN/AM Betamicon®/Aquamicon® (BN4AM)

Size of filter or element _____

RFD: 60, 110, 160, 240, 330, 660, 950, 1300

Operating pressure _____

D = 25 bar

Type of change-over _____

A Ball

Type and size of connection _____

Type	Connection	Filter size							
		60	110	160	240	330	660	950	1300
C	G 3/4	●	●						
D	G 1			●	●				
G	G 2					●			
L	SAE DN 50 (2")					●			
M	SAE DN 80 (3")						●		
N*	G3						●		
P	SAE DN 100 (4")							●	●

* This port G3 applies to filter outlet only

Filtration rating in µm _____

BN/HC, V: 3, 5, 10, 20 P/HC: 10, 20 AM: 40
 W/HC: 25, 50, 100, 200 BN/AM: 3, 10

Type of clogging indicator _____

Y plastic blanking plug in indicator port
 A stainless steel blanking plug in indicator port
 B visual
 C electrical
 D visual and electrical
 for other clogging indicators, see brochure no. 7.050../..

Type code _____

1

Modification number _____

X the latest version is always supplied

Supplementary details _____

B. special cracking pressure of bypass (e.g. B6 = 6 bar)
 KB without bypass valve
 L... light with appropriate voltage (24V, 48V, 110V, 220V)
 LED 2 light emitting diodes up to 24 Volt
 SO136 filter housing of RFD 330 in EN-GJS-400-15
 V FPM seals
 only for clogging indicators type D

2.2 REPLACEMENT ELEMENT

0330 R 010 BN4HC /-V

Size _____

0060, 0110, 0160, 0240, 0330, 0660, 0950, 1300

Type _____

R

Filtration rating in µm _____

BN/HC, V: 003, 005, 010, 020 P/HC: 010, 020 AM: 040
 W/HC: 025, 050, 100, 200 BN4AM: 003, 010

Filter material _____

BN4HC, V, W/HC, P/HC, BN4AM, AM

Supplementary details _____

V (for descriptions, see point 2.1)

2.3 REPLACEMENT CLOGGING INDICATOR

VR 2 D . X /-L24

Type _____

VR return line indicator up to 25 bar operating pressure

Pressure setting _____

2 standard 2 bar, others on request

Type of clogging indicator _____

D (see Point 2.1)

Modification number _____

X the latest version is always supplied

Supplementary details _____

L..., LED, V (for descriptions, see point 2.1)

3. FILTER CALCULATION / SIZING

The total pressure drop of a filter at a certain flow rate Q is the sum of the housing Δp and the element Δp and is calculated as follows:

$$\Delta p_{\text{total}} = \Delta p_{\text{housing}} + \Delta p_{\text{element}}$$

$$\Delta p_{\text{housing}} = (\text{see Point 3.1})$$

$$\Delta p_{\text{element}} = Q \cdot \frac{SK^*}{1000} \cdot \frac{\text{viscosity}}{30}$$

(*see point 3.2)

For ease of calculation, our Filter Sizing Program is available on request free of charge.

NEW: Sizing online at www.hydac.com

3.1 Δp -Q HOUSING CURVES BASED ON ISO 3968

The housing curves apply to mineral oil with a density of 0.86 kg/dm³ and a kinematic viscosity of 30 mm²/s. In this case, the differential pressure changes proportionally to the density.

RFD 60, 110

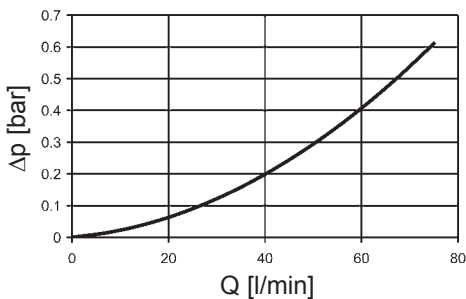

RFD 160, 240

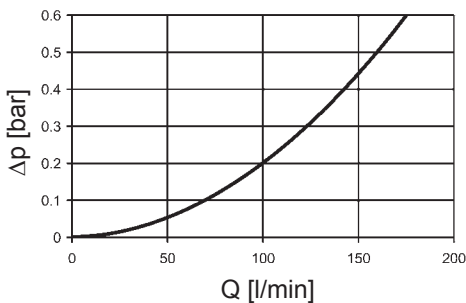

RFD 330

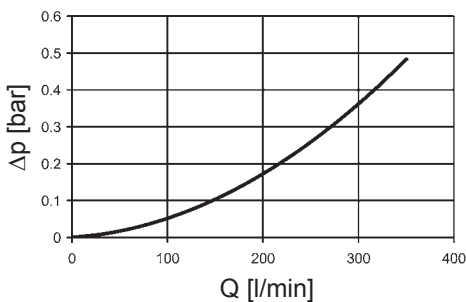

RFD 660, 950

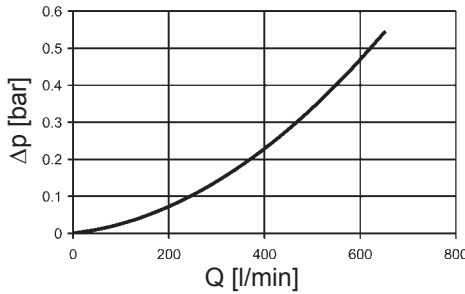

RFD 1300

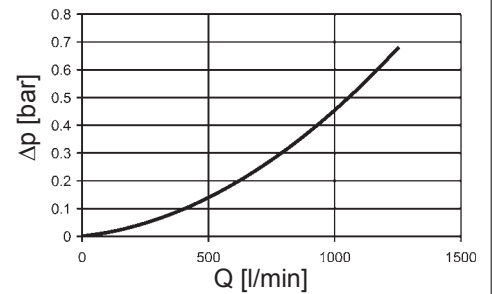

3.2 GRADIENT COEFFICIENTS (SK) FOR FILTER ELEMENTS

The gradient coefficients in mbar/(l/min) apply to mineral oils with a kinematic viscosity of 30 mm²/s. The pressure drop changes proportionally to the change in viscosity.

RFD	V				W/HC
	3 μm	5 μm	10 μm	20 μm	
60	15.9	9.3	5.4	3.3	0.90
110	7.6	5.1	3.0	2.0	0.495
160	4.9	3.5	2.4	1.5	0.338
240	3.2	2.6	1.7	1.2	0.225
330	2.1	1.7	1.1	0.8	0.162
660	1.0	0.8	0.6	0.4	0.081
950	0.7	0.6	0.4	0.2	0.054
1300	0.5	0.4	0.3	0.2	0.045

BN4HC: RFD 60

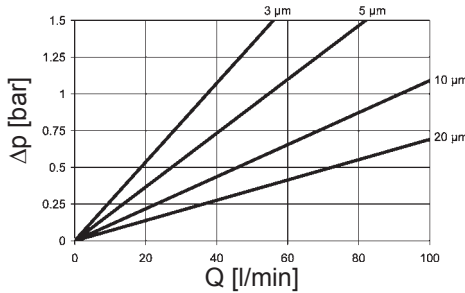

BN4HC: RFD 110

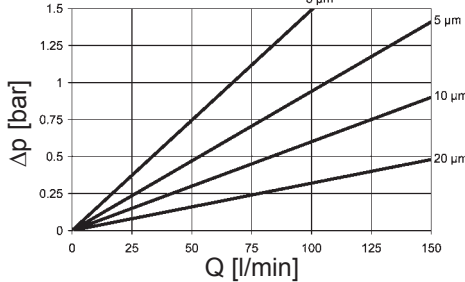

BN4HC: RFD 160

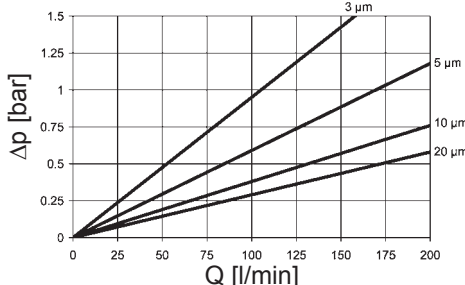

BN4HC: RFD 240

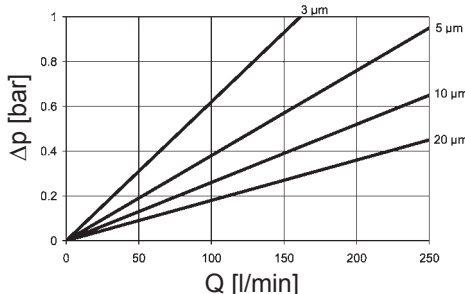

BN4HC: RFD 330

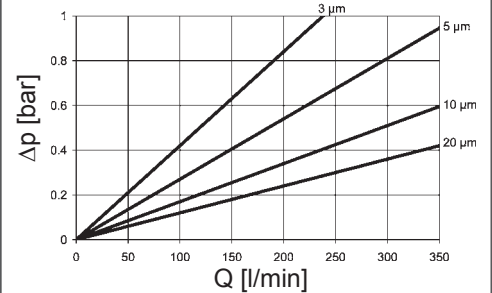

BN4HC: RFD 660

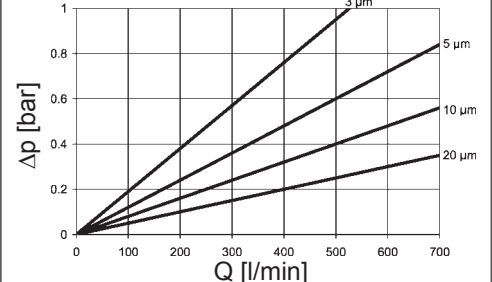

BN4HC: RFD 950

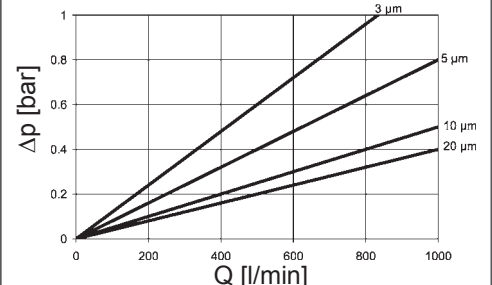

BN4HC: RFD 1300

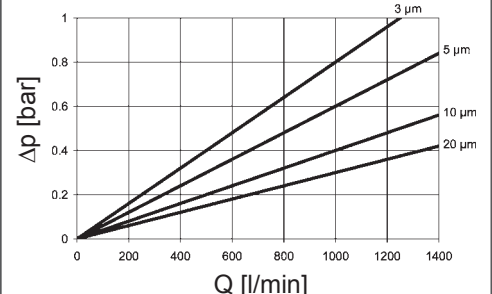

4. DIMENSIONS

RFD 60-240

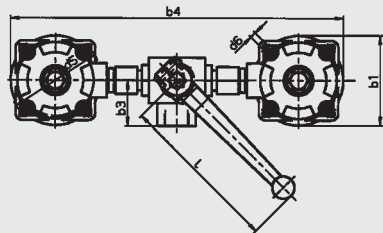
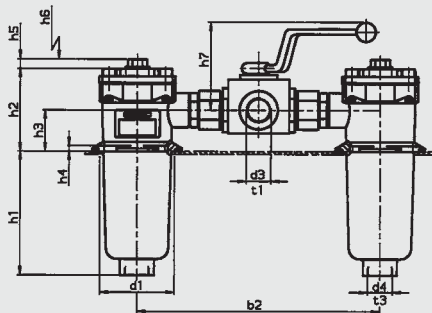

RFD 330

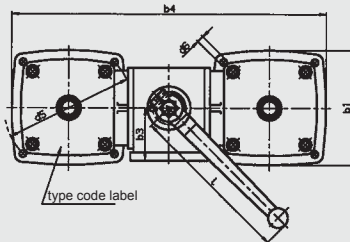
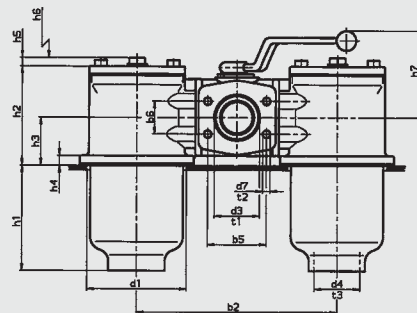

RFD 660-1300

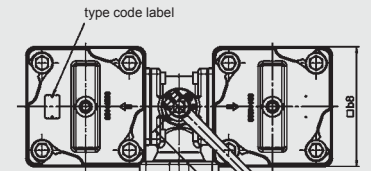
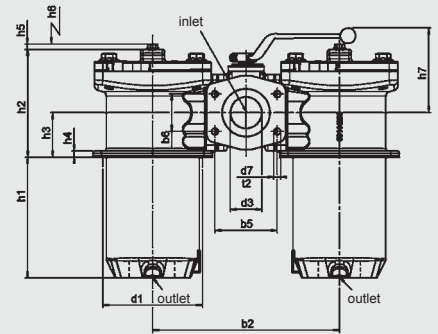

View from below

outlet: RFD 660 DAM
RFD 950 DAP
RFD 1300 DAP

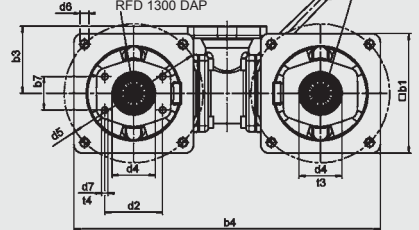

RFD	60	110	160	240	330	660	950	1300
b1	96	96	126	126	150	195	250	250
b2±1.5	260.5	260.5	335.5	335.5	254	330	390	410
b3	47.5	47.5	56.5	56.5	69	100	140	140
b4	357	357	461	461	404	540	640	660
b5	-	-	-	-	77.8	106.5	130.2	130.2
b6	-	-	-	-	42.9	61.9	77.8	77.8
b7	-	-	-	-	-	61.9	69.9	77.8
b8	-	-	-	-	-	210	244	244
d1	80	80	106	106	135	180	208	208
d2	-	-	-	-	-	106.4	120.7	130.2
d3	G ¾	G ¾	G 1	G 1	G 2 / SAE DN 50 (2")	SAE DN 80 (3")	SAE DN 100 (4")	SAE DN 100 (4")
d4	G ¾	G ¾	G 1¼	G 1¼	G 2	G 3 or SAE DN 80 (3")	SAE DN 90 (3½")	SAE DN 100 (4")
d5	100	100	135	135	170	220	290	290
d6 ¹⁾	Ø8 (M5)	Ø8 (M5)	Ø9.5 (M6)	Ø9.5 (M6)	Ø16 (M8)	Ø14 (M12)	Ø18 (M16)	Ø16 (M16)
d7 ²⁾	-	-	-	-	- / M12	M16	M16	M16
h1	66	133	89	150	139	246	252.5	330.5
h2	88	88	108	108	130	203	225	269
h3	44	44	54	54	63	83	93	121
h4	6	6	6	6	13	13	13	13
h5	11	11	11	11	11	8	8	8
h6	80	145	120	180	180	320	385	485
h7	92	92	95	95	110	114	170	170
l	173	173	173	173	229	229	318	318
t1 ²⁾	16	16	24	24	24 / -	-	-	-
t2 ²⁾	-	-	-	-	- / 17	20	25	25
t3	17	17	20	20	27	28	-	-
t4	-	-	-	-	-	18	20	20
Weight incl. element [kg]	3.2	3.7	7.0	7.8	13.4	72.0	105.0	118.0
Volume of pressure chamber [l]	2x 0.30	2x 0.60	2x 1.00	2x 1.40	2x 2.00	2x 6.80	2x 10.30	2x 13.50

¹⁾ Mounting hole for bolt

²⁾ Refers to the appropriate port (d3)

NOTE

The information in this brochure relates to the operating conditions and applications described.

For applications and operating conditions not described, please contact the relevant technical department.

Subject to technical modifications.

HYDAC FILTERTECHNIK GMBH
Industriegebiet
D-66280 Sulzbach/Saar, Germany
Tel.: 0 68 97 / 509-01
Fax: 0 68 97 / 509-300
Internet: www.hydac.com
E-mail: filter@hydac.com