

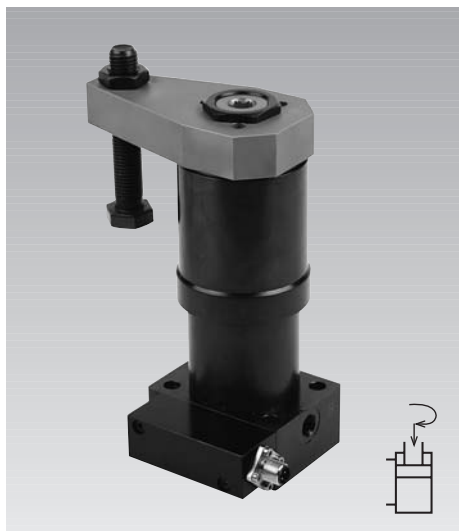

**Swing Clamps with Reinforced Swing Mechanism**  
bottom flange, inductive position monitoring  
double acting, max. operating pressure 500 bar



**Advantages**

- Inductive position monitoring of the clamping arm
- Electricity integrated and ready for connection
- Inductive proximity switches protected by a cap
- One common plug connection
- Short circuit proof
- High process safety
- Sturdy swing mechanism
- Insensitive against high flow rates
- Piston rod protected against swarf
- 2 sizes available
- Alternatively pipe connection or manifold-mounting connection
- Connection for positive air pressure protection
- Mounting position: any

**Application**

Hydraulic swing clamps are used for clamping of workpieces when it is essential to keep the clamping area free of straps and clamping components for unrestricted workpiece loading and unloading.

Due to the sturdy swing mechanism and the electrical monitoring of the clamping arm position this line is particularly suitable for

- Clamping fixtures with automated workpiece loading
- Automatic manufacturing systems
- Transfer lines
- Assembly lines
- Test systems for motors, gears and axes

**Function**

The hydraulic swing clamp is a double-acting pull-type cylinder where a part of the total stroke is used to swing the piston.

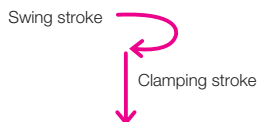

Starting from the off-position alternatively with clockwise or counterclockwise swing motion and swing angles of 45°, 60°, 90° or without swing motion (0°) available. Special angles on request.

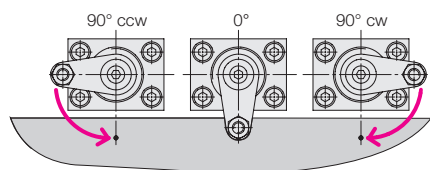

**Description**

This further development of the well proven line with sturdy swing mechanism allows the electrical monitoring of the clamping arm position.

At the clamping arm a cap is fixed that is used as control cams for two inductive proximity switches fixed at the body and to protect these against swarf.

The hollow space is vented by a connection in the flange and can be supplied with air sealing to avoid the penetration of liquids.

The two proximity switches are connected to a housing mounted at the side as well as to a common socket.

One proximity switch signals the position "Unclamped", the other the position "Clamped".

**Process safety**

To increase the process safety, the line with reinforced swing mechanism was designed without snap-out overload protection device. During clamping the reinforced swing mechanism endures a collision of the clamping arm with the workpiece up to a pressure of 100 bar.

**Important notes!**

Swing clamps must only be used for clamping of workpieces in industrial applications and may only be operated with hydraulic oil. They can generate very high forces. The workpiece, the fixture or the machine must be in the position to compensate these forces. In the effective area of piston rod and clamping arm there is the danger of crushing. The manufacturer of the fixture or the machine is obliged to provide effective protection devices.

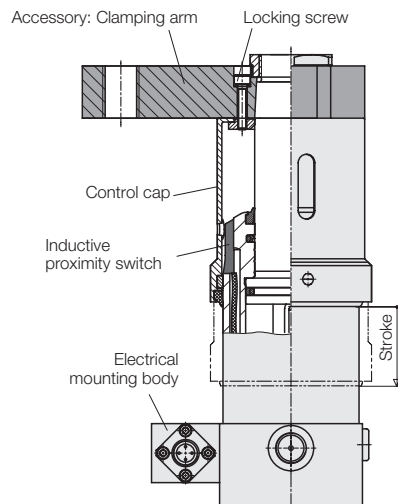

**Connecting possibilities**

**Pipe thread**

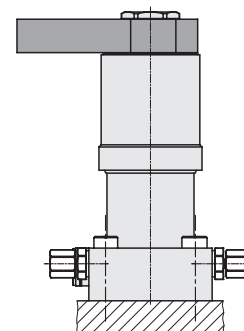

**Drilled channels**

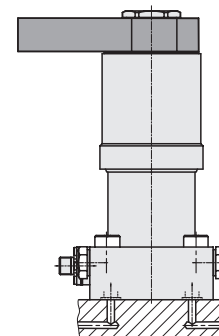

**Application example**

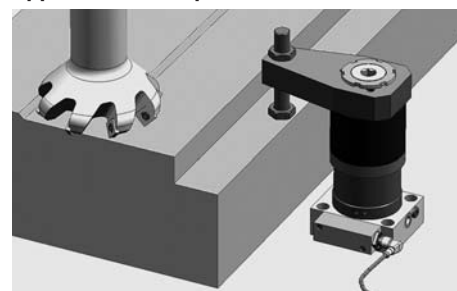

# Dimensions • Technical characteristics

## Important notes

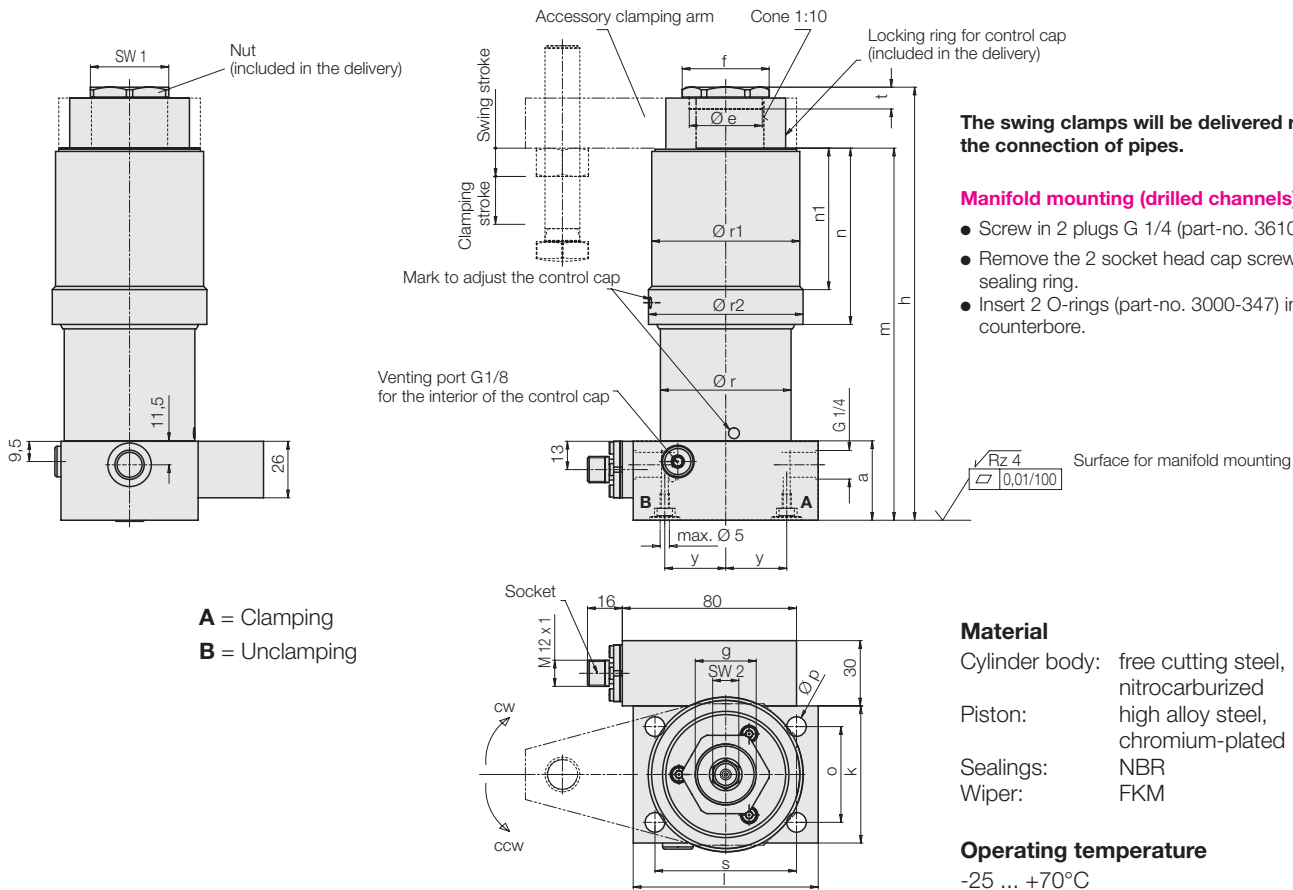

The swing clamps will be delivered ready for the connection of pipes.

### Manifold mounting (drilled channels)

- Screw in 2 plugs G 1/4 (part-no. 3610-006)
- Remove the 2 socket head cap screw with sealing ring.
- Insert 2 O-rings (part-no. 3000-347) in the counterbore.

### Material

Cylinder body: free cutting steel, nitrocarburized  
 Piston: high alloy steel, chromium-plated  
 Sealings: NBR  
 Wiper: FKM

### Operating temperature

-25 ... +70°C

Total stroke	[mm]	35	38
Swing stroke	[mm]	13	18
Clamping stroke	[mm]	22	20
Operating pressure, min.	[bar]	30	30
Max. oil flow rate	[cm <sup>3</sup> /s]	20	55
Oil volume/stroke	[cm <sup>3</sup> ]	15.8	43.8
Oil to return	[cm <sup>3</sup> ]	44	119
a	[mm]	36.5	38.5
Ø e	[mm]	33.5	55.5
f	[mm]	40	68
g	[mm]	M 28 x 1.5	M 45 x 1.5
h	[mm]	199	225.5
k	[mm]	63	90
l	[mm]	85	115
m	[mm]	171	185.5
n	[mm]	81	84
n1	[mm]	65	68
o	[mm]	44	68
Ø p	[mm]	9	16
Ø r	[mm]	60	85
Ø r1	[mm]	68	95
Ø r2	[mm]	71	95
s	[mm]	65	90
t	[mm]	10	12
y	[mm]	28	37.5
SW 1	[mm]	36	-
SW 2	[mm]	12	17

### Part-no.

0 degree	<b>1895-245VDH35</b>	<b>1897-245VDH38</b>
Swing direction clockwise	<b>1895-1X5VDH35</b>	<b>1897-1X5VDH38</b>
Swing direction counterclockwise	<b>1895-2X5VDH35</b>	<b>1897-2X5VDH38</b>

### Swing angle

Tolerance ± 1°

**0** = 90°

**2** = 60°

**3** = 45°

### Important notes

When selecting the clamping arm, the operating pressures assigned in the clamping force diagram have to be considered. The max. oil flow rate as per chart is valid for vertical mounting position in connection with standard clamping arms.

When using long clamping arms, not only the operating pressure but also the flow rate has to be reduced.

A flow rate throttling always has to be effected in the supply line to the swing clamp. This avoids pressure intensification and thereby pressures exceeding 500 bar.

For use in coolant areas the venting port has to be supplied with air sealing.

Despite of the reinforced swing mechanism a collision of the clamping arm in radial direction has to be avoided.

When mounting or dismounting the clamping arm, it is imperative to hold the clamping arm or to back up at the hexagon socket in the piston during tightening or untightening of the fixing nut.

Operating conditions, tolerances and other data see data sheet A 0.100.

## Accessories: Clamping arms Effective clamping force

### Accessory: Clamping arm

The clamping arm is not included in the delivery of the swing clamp. The delivered swing clamp is provided with a locking ring at which the control cap is fixed. This locking ring will be exchanged by the customer against the provided clamping arm.

The clamping arms available as accessory have the maximum length for the maximum admissible operating pressure of 200 bar.

For clamping arms of different shape and length the connecting dimensions as per drawing and chart are to be considered. The below clamping force diagrams indicate for different clamping arm lengths the maximum operating pressures and the attainable clamping forces.

The control cap is fixed by 3 screws at the clamping arm and follows its movement. When mounting the clamping arm the control cap has to be readjusted. (see page 4).

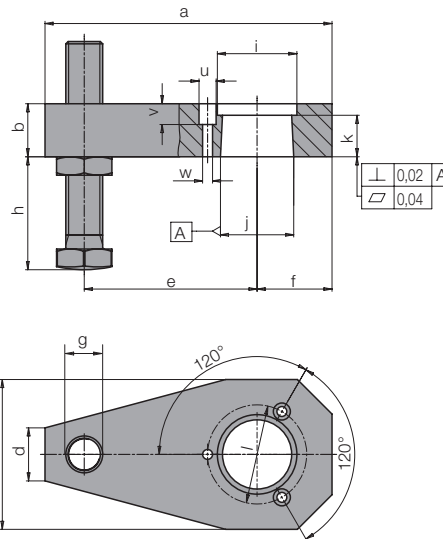

### Clamping arm with thread and contact bolt, max. 200 bar, material 42 Cr Mo 4

Swing clamp	a	b	c	d	e	f	g	h max.	h min.	i	j	k	l	u	v	w	Part-no.
<b>1895-</b>	124,5	23	65	23	75	32,5	M16	79	9	34,5	31,8 <sup>+0,1 -0,05</sup>	18 <sup>+0,2</sup>	43	7,4	9	4,3	<b>0354-106</b>
<b>1897-</b>	183	34	90	40	120	45	M20	98	12	56	49,8 <sup>+0,1 +0,05</sup>	28 <sup>+0,2</sup>	68	9,5	15,5	5,5	<b>0354-107</b>

### Clamping arm without thread and contact bolt, max. 200 bar, material 42 Cr Mo 4

Swing clamp	a	b	c	d	f	h max.	h min.	i	k	l	u	v	w	Part-no.	
<b>1895-</b>	124,5	23	65	23	32,5	79	9	34,5	31,8 <sup>+0,1 -0,05</sup>	18 <sup>+0,2</sup>	43	7,4	9	4,3	<b>3548-658</b>
<b>1897-</b>	183	34	90	40	45	98	12	56	49,8 <sup>+0,1 +0,05</sup>	28 <sup>+0,2</sup>	68	9,5	15,5	5,5	<b>3548-659</b>

### Effective clamping force $F_{Sp}$ as a function of the operating pressure $p$

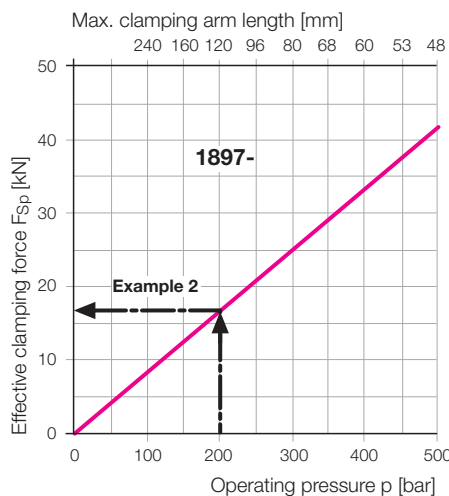
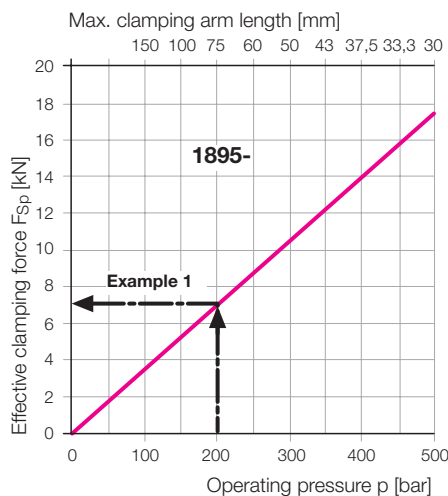

#### Example 1: 1895-105VDH35.

An operating pressure  $p$  of 200 bar in connection with standard clamping arm 0354-106 of max. arm length  $e = 75$  mm results in an effective clamping force  $F_{Sp}$  of 7 kN.

#### Increase of clamping force by shortening the clamping arm

#### Example 2: 1897-105VDH38.

When using the standard clamping arm 0354-107 of a length  $e = 120$  mm at the max. operating pressure of 200 bar a clamping force  $F_{Sp}$  of 17 kN results.

a) If the length of the clamping arm is shortened to  $e = 80$  mm, the operating pressure can be increased up to 300 bar. Then there will be a clamping force of  $F_{Sp}$  of 25 kN.

b) If a longer clamping arm is required, the max. operating pressure has to be lowered, therefore the clamping force  $F_{Sp}$  is reduced.  
Clamping arm:  $e = 240$  mm  
Max. operating pressure: 100 bar  
Clamping force  $F_{Sp} = 8$  kN

## Inductive proximity switches

Two proximity switches are fixed in a slot provided in the body. The cables are passed through a bore hole into the below mounting body.

## Function chart

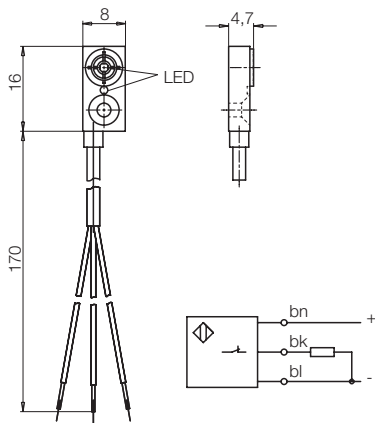
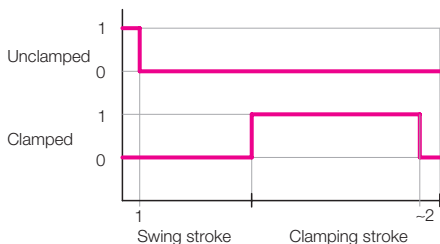

## Technical characteristics

Design	
operating voltage DC	24 VDC
Operating voltage	5 ... 30 VDC
Residual ripple max.	10%
Design operational current Ie	100 mA
No-load current damped	10 mA
Switching output	PNP
Switching function	Break contact
Rated operating distance	1.5 mm
Environmental temperature	-25 ... +70 °C
Short circuit protection	yes
Protected against reverse battery	no
Function display	LED
Code class	IP 67

**Part-no. 0188-517**

## Electrical mounting body

The mounting body is fixed at the flange and sealed against swarf and coolants. On the printed board there are pins for the plugs of both proximity switches. The electrical lines are connected to a 4-pole socket.

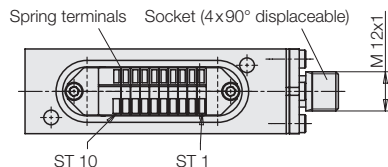

## Terminal connections

Plug	ST1 brown (bn)
	ST2 blue (bl)
	ST3 white (wh)
	ST4 black (bk)
Switch "Clamped"	ST5 brown (bn)
	ST6 blue (bl)
	ST7 black (bk)
Switch "Unclamped"	ST8 brown (bn)
	ST9 blue (bl)
	ST10 black (bk)

## Socket

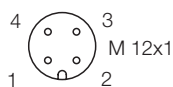

## Pinouts

1	brown	plus (24 VDC)
2	white	Switch "Clamped"
3	blue	minus (0 VDC)
4	black	Switch "Unclamped"

## Electric circuit diagram

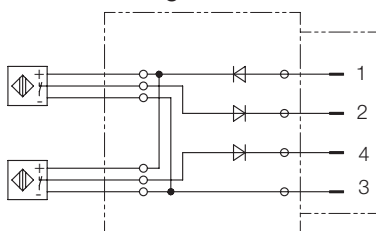

## Accessories

### Connector with connecting cable

For the connection a right angle plug and a straight circular connector are available. The right angle plug has 3 luminous diodes for the operating voltage and the two switching positions. The straight connector is not available with luminous diodes.

Right angle plug with LED  
**Part-no. 3829-257**

Circular connector  
**Part-no. 3829-267**

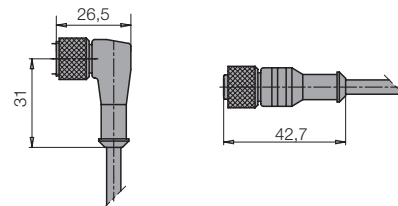

## Technical characteristics

Operating voltage	10 - 30 V DC
Protection as per DIN 40050	IP 67
Environmental temperature	-25°C to +80°C
Cable, length of cable	PUR, 5 m
Only for right angle plugs:	
LED: Operating voltage	(green)
LED: "Unclamped"	(yellow)
LED: "Clamped"	(white)

## Adjustment of control cap

The control cap is fixed by 3 screws at the clamping arm and follows its movement. When mounting the clamping arm the control cap has to be readjusted.

1. Fix control cap and disk with 3 screws at the clamping arm.
2. Put, align and tighten the clamping arm onto the cone of the piston as per the operating instructions.
3. Clamp several times in order to determine if the angle position is correct. Danger of crushing!
4. Release the locking screws so that it is possible to turn the control cap.
5. Move the piston to clamping position. Danger of crushing!
6. Turn the control cap until the marks at the swing clamp body and the control cap are one above the other.
7. Tighten locking screws.
8. Clamp and unclamp several times. Check the function by control of the two luminous diodes at the right angle plug.

