



Hinge Clamps 70 bar
with metallic wiper edge and optional position monitoring
double acting, max. operating pressure 70 bar



Advantages

- High clamping force in the low-pressure range
- Very short clamping time
- Compact design partially recessible
- 5 sizes available
- Clamping possible without side loads
- Clamping lever can be swivelled into small recesses
- Long clamping lever adaptable to the workpiece contour
- FKM wiper protected by metallic wiper edge
- Position monitoring available as accessory
- Mounting position: variable

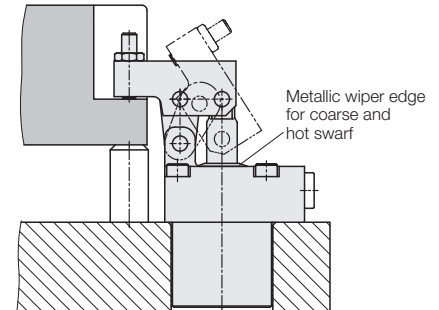

Application

Hydraulic hinge clamps are used for clamping of workpieces, when it is essential to keep the clamping area free of straps and clamping components for unrestricted workpiece loading and unloading.

A clamping recess in the workpiece a little bit wider than the clamping lever is sufficient as clamping surface.

The special kinematics allow clamping without side loads of workpieces which are very sensitive against deformation.

This series with an operating pressure of 70 bar is designed for the direct connection to the low-pressure hydraulics of machine tools.

In combination with the optional pneumatic or electrical position monitorings hinge clamps are particularly suitable for:

- Automatic manufacturing systems with very short cycle times
- Clamping fixtures with workpiece loading by handling systems
- Transfer lines
- Test systems for motors, gears and axes
- Assembly lines
- Special machine tools

Description

The hinge clamp is a double acting hydraulic cylinder with integrated clamping lever. When pressurising the element, the piston moves upwards and swivels the clamping lever over the hinges forwards and at the same time downwards onto the workpiece. The piston force is deviated by 180° and, depending on the lever length, the force is available as clamping force (see page 4).

The kinematics are so designed that no side loads enter into the workpiece, if the clamping surface is at the same height with as the centre of rotation of the clamping lever (see comparison „Forces at the clamping point“).

All sizes are optionally available with switch rod for external position monitoring.

Electrical and pneumatic position monitorings for the clamping and unclamping position are available as accessories.

Forces at the clamping point

Conventional lever mechanism of other manufacturers

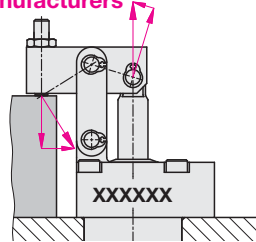

Lever mechanics without side loads ROEMHELD system

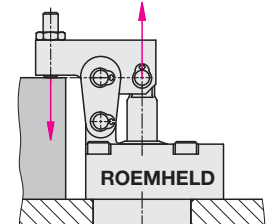

Installation and connecting possibilities

Pipe thread

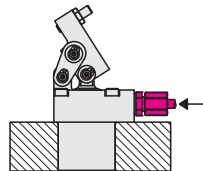

Drilled channels

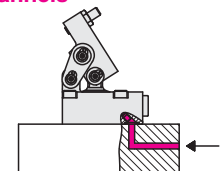

Versions

Without switch rod
(Option: Long clamping lever)

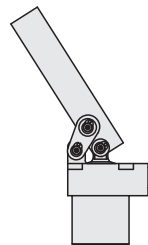

With switch rod

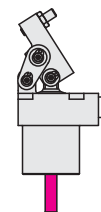

Accessory

Pneumatic position monitoring

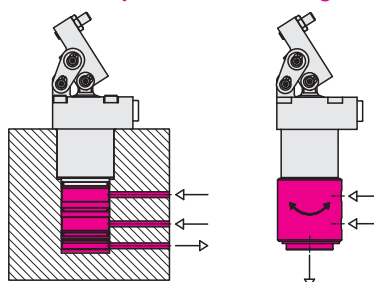

Electrical position monitoring

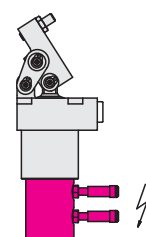

Versions: Without / With Switch Rod
Dimensions • Accessories

Without switch rod
1826-7X31

Clamping lever with contact bolt

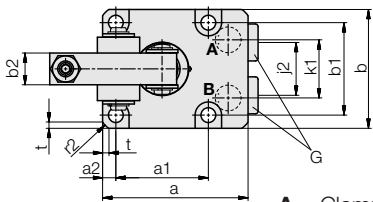
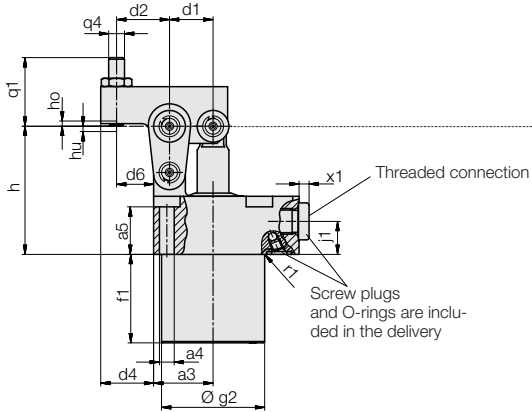

Connection pattern
for O-ring sealing

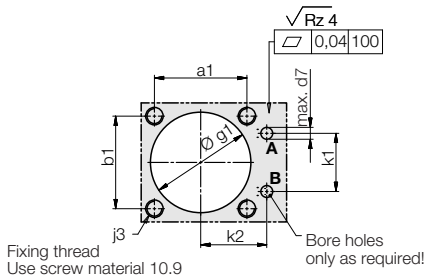

With switch rod
1826-7X40

Without clamping lever

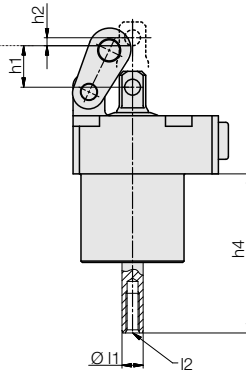

With switch rod
1826-7X41

Clamping lever with contact bolt

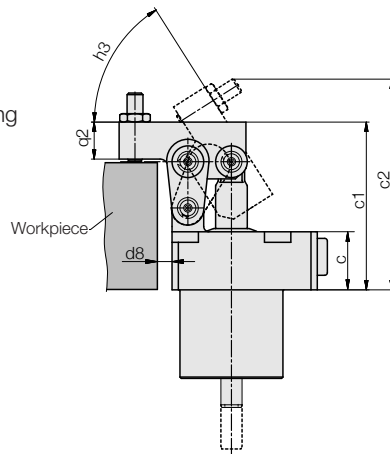

With switch rod
1826-7X42

Clamping lever, long

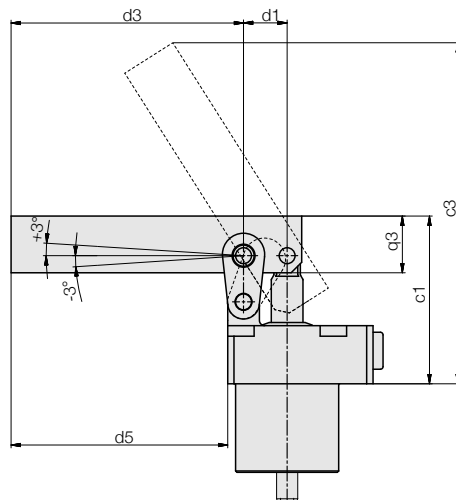

Accessories

Pneumatic position monitoring (page 5)
Cartridge type

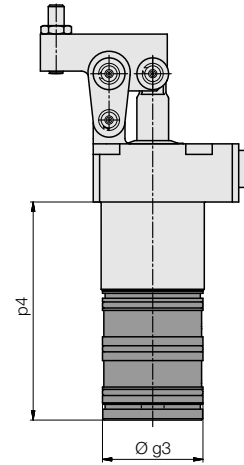

Connection: pipe thread

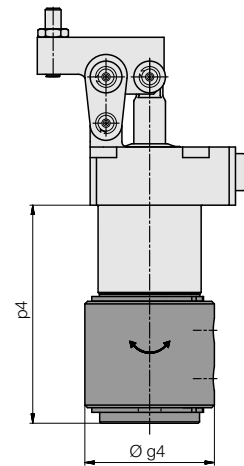

Inductive position monitoring (page 6)

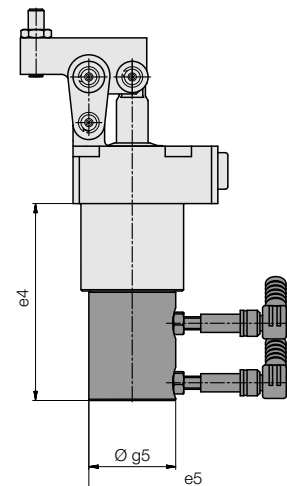

Technical data

Size		1	2	3	4	5	
Clamping force max.	length of clamping lever d2						
	without switch rod	[kN]	2.6	3.5	4.4	7.3	12.1
	with switch rod	[kN]	2.3	3.1	4	6.8	11.5
Piston force	without switch rod	[kN]	3.4	4.9	6.7	10.6	17.2
	with switch rod	[kN]	3	4.3	6.1	9.8	16.4
Piston Ø		[mm]	25	30	35	44	56
Piston rod Ø		[mm]	12	14	14	16	22
Piston stroke		[mm]	18.7	20.7	24	26	32
Piston area	clamping						
	without switch rod	[cm²]	4.9	7.06	9.62	15.2	24.6
	with switch rod	[cm²]	4.4	6.28	8.83	14	23.4
	Unclamping	[cm²]	3.77	5.52	8.08	13.1	20.8
Oil volume	clamping						
	without switch rod	[cm³]	9.2	14.7	23.1	39.6	78.8
	with switch rod	[cm³]	8.3	13	21.2	36.6	75.2
	Unclamping	[cm³]	7.1	11.45	19.4	34.3	66.7
Adm. flow rate		[cm³/s]	16	25	40	75	150
a		[mm]	55	60	66	82	96
a1		[mm]	35	40	46	56	68
a2		[mm]	5	5	5.5	7	9
a3		[mm]	22.5	25	28.5	35	43
Ø a4		[mm]	5.6	5.6	6.8	9	11
a5		[mm]	18	17	17	20	20
b		[mm]	45	50	57	70	86
b1		[mm]	35	40	46	56	68
b2		[mm]	12	12	16	19	22
c		[mm]	22	20.8	22	26	32
c1		[mm]	63.5	68.5	77	93	110
c2		[mm]	79.8	85.5	97	116.5	138.9
c3		[mm]	129.1	152.8	157.6	204	226.8
d1		[mm]	16.5	18.5	21	24.5	30.5
d2		[mm]	20	23.5	29	32	39
d3		[mm]	88	110.5	108	148.5	159.5
d4		[mm]	20	23	29.5	31.5	37.5
d5		[mm]	82	104	100.5	138	147
d6		[mm]	14	17	21.5	21.5	26.5
Ø d7		[mm]	4	4	4	6	6
d8 min.		[mm]	3	4	7	7	8
e4		[mm]	75.5	84.5	91.5	103.5	116.9
e5		[mm]	76	82	83	84	84
f1		[mm]	33.5	39.5	42.5	47	55
G			G1/8	G1/8	G1/8	G1/4	G1/4
Ø g1 max.		[mm]	40	48	54	64	79
Ø g2 ±0.1		[mm]	39	47	53	63	78
Ø g3		[mm]	38	42	42	45	45
Ø g4		[mm]	49	53	52.5	62.5	62.5
Ø g5		[mm]	33	42	42	45	45
h	ideal clamping point	[mm]	48.5	51.5	56	67	79
ho	upper end of clamping range	[mm]	1	1.2	1.5	1.8	2
hu	lower end of clamping range	[mm]	1.1	1.3	1.5	1.7	2.1
h1	stroke up to ideal clamping point	[mm]	15.7	17.7	21	23	29
h2	stroke up to end of clamping stroke	[mm]	3	3	3	3	3
h3		[°]	57.6	58.6	60.4	57.6	57.4
h4	extended -h1 -h2	[mm]	60.2	68.2	72.6	78.1	93.6
j1		[mm]	12.5	12.8	14	14	14
j2		[mm]	20	22	23	30	38
j3	fixing thread		M5	M5	M6	M8	M10
k1		[mm]	22	24	28	36	45
k2		[mm]	25	28	30.5	36	42
Ø l1 f7		[mm]	8	10	10	12	12
l2			M5x15 deep	M6x11.5 deep	M6x11.5 deep	M8x16 deep	M8x16 deep
p4		[mm]	82.5	93.5	98.5	107	121.5
q1		[mm]	26	26	29	39	48
q2		[mm]	14	16	20	25	30
q3		[mm]	21.5	26	30	36.5	45
q4			M6	M6	M8	M10	M12
r1		[mm]	0.4	0.4	0.4	0.4	0.4
r2		[mm]	7	9	9	11	12
t		[mm]	2.4	3.9	2.5	4	4.7
Weight		[kg]	1	1.2	1.5	2.6	4.5
without switch rod							
	without clamping lever		1826-7130	1826-7230	1826-7330	1826-7430	1826-7530
	with clamping lever (contact bolt)		1826-7131	1826-7231	1826-7331	1826-7431	1826-7531
	with long clamping lever		1826-7132	1826-7232	1826-7332	1826-7432	1826-7532
Part no. with switch rod							
	without clamping lever		1826-7140	1826-7240	1826-7340	1826-7440	1826-7540
	with clamping lever (contact bolt)		1826-7141	1826-7241	1826-7341	1826-7441	1826-7541
	with long clamping lever		1826-7142	1826-7242	1826-7342	1826-7442	1826-7542
Spare O-ring		[mm]	7 x 1.5	7 x 1.5	7 x 1.5	8 x 1.5	8 x 1.5
Part no.			3000-342	3000-342	3000-342	3000-343	3000-343

Clamping force diagram

Calculations • Connecting dimensions clamping lever

Clamping force diagram

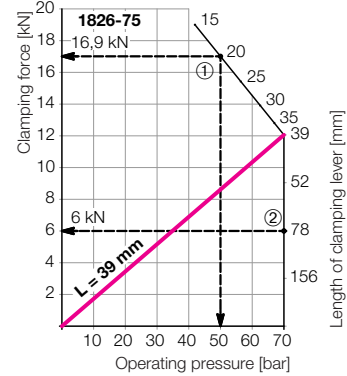
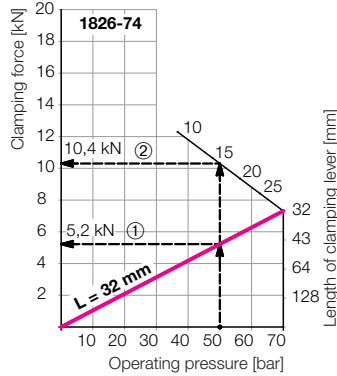
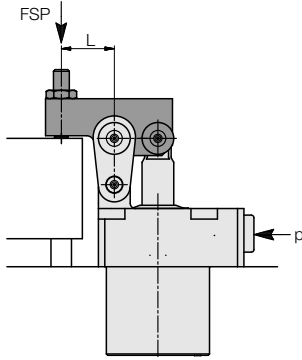
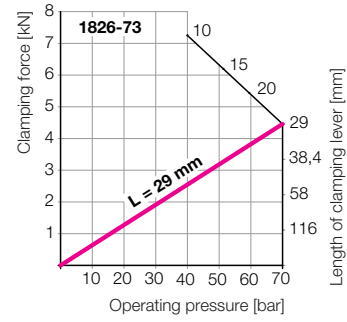
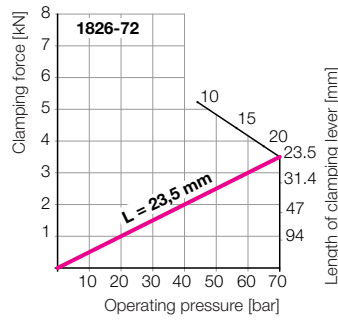
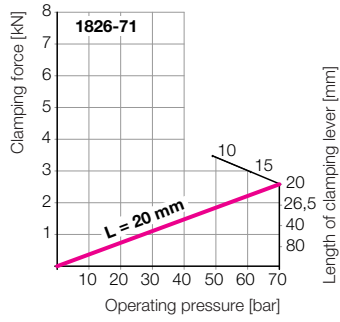

Calculations

1. Length L of clamping lever is known

1.1 Admissible operating pressure

$$p_{adm.} = \frac{B}{\frac{C}{L} + 1} \leq 70 \text{ bar}$$

1.2 Effective clamping force

$$(p_{adm.} > 70 \text{ bar}) \rightarrow F_{Sp} = \frac{A}{L} * 70 \quad [\text{kN}]$$

$$(p_{adm.} < 70 \text{ bar}) \rightarrow F_{Sp} = \frac{A}{L} * p_{adm.} \quad [\text{kN}]$$

2. Min. length of clamping lever

$$L_{min} = \frac{C}{\frac{B}{p} - 1} \quad [\text{mm}]$$

L, L_{min} = length of clamping lever [mm]

p, p_{adm.} = operating pressure [bar]

A, B, C = constants as per chart

Example ① Hinge clamp 1826-7432

Operating pressure 50 bar

Standard clamping lever L = 32 mm

Effective clamping force

$$F_{Sp} = \frac{A}{L} * p = \frac{3.35}{32} * 50 = 5.2 \text{ kN}$$

Example ② Hinge clamp 1826-7432

Operating pressure 50 bar

Min. length of clamping lever

$$L_{min} = \frac{C}{\frac{B}{p} - 1} = \frac{22.05}{\frac{118.23}{50} - 1} = 16 \text{ mm}$$

Effective clamping force

$$F_{Sp} = \frac{A}{L} * p = \frac{3.35}{16} * 50 = 10.4 \text{ kN}$$

Example ③ Hinge clamp 1826-7532

Special clamping lever L = 20 mm

Admissible operating pressure

$$p_{adm.} = \frac{B}{\frac{C}{L} + 1} = \frac{119.26}{\frac{27.45}{20} + 1} = 50.2 \text{ bar}$$

Effective clamping force

$$F_{Sp} = \frac{A}{L} * p_{adm.} = \frac{6.76}{20} * 50 = 16.9 \text{ kN}$$

Example ④ Hinge clamp 1826-7532

Special clamping lever L = 78 mm

Admissible operating pressure

$$p_{adm.} = \frac{B}{\frac{C}{L} + 1} = \frac{119.26}{\frac{27.45}{78} + 1} = 88.2 \text{ bar} > 70 \text{ bar}$$

Effective clamping force

The max. operating pressure is 70 bar, thus

$$F_{Sp} = \frac{A}{L} * 70 = \frac{6.76}{78} * 70 = 6 \text{ kN}$$

Constant	1826-71	1826-72	1826-73	1826-74	1826-75
A	0.73	1.18	1.82	3.35	6.76
A*	0.65	1.05	1.67	3.11	6.45
B	121.97	119.6	115.62	118.23	119.27
B*	135.89	134.5	125.9	127.73	125
C	14.85	16.65	18.9	22.05	27.45

A*, B* for version with switch rod

Connecting dimensions for self-manufactured clamping levers

Size	1	2	3	4	5
d1 [mm]	16.5	18.5	21	24.5	30.5
q3 [mm]	21.5	26	30	36.5	45
s1 [mm]	5.5	6	6	7	10
Ø s2 H7 [mm]	6	8	8	10	14
Ø s3 H7 [mm]	6	6	7	8	12
t1 -0.1 [mm]	12	12	16	19	22
t2 [mm]	6.5	9	9	10.5	14
t3 [mm]	4	3	4.3	5.1	6.6
t4 [mm]	4	17	22	22	31
u1 [mm]	14.5	17.5	17.5	19	26
u2 [mm]	16	16.5	17	19	26
u3 +0.1 [mm]	6	6	8	10	11

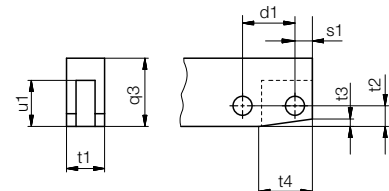
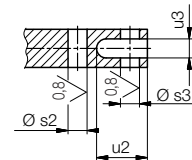

Accessories

Pneumatic position monitoring (not adjustable)

Application

The pneumatic position monitoring signals the following conditions by closing two bore holes:

1. Piston retracted and clamping lever in off-position
2. Piston in clamping area and clamping lever in clamping position.

For each control function, a pneumatic line has to be provided at the clamping fixture.

Description

When moving to a switching position, the air pressure in the supply line increases and operates a differential pressure switch or an electro-pneumatic pressure switch.

Pneumatic port

Cartridge type

The hinge clamp with the mounted position monitoring and inserted O-rings is put into the location hole and immediately ready for use.

Mounting body

The mounting body is put onto the cartridge-type version and held by the supplied safety ring. The pneumatic ports M5 can be rotated by 360°.

Monitoring by pneumatic pressure switch

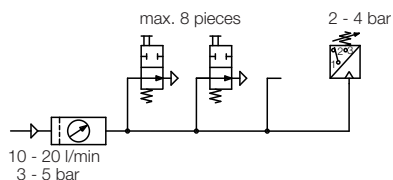

For the evaluation of the pneumatic pressure increase standard pneumatic pressure switches can be used. With one pressure switch up to 8 position monitorings can be controlled (see circuit diagram).

It has to be considered that process-safe functioning of pneumatic controls is only guaranteed with throttled air pressure and air flow rate.

Technical data

Port	Drilled channels or thread M5
Nominal diameter	2 mm
Max. air pressure	10 bar
Range of operating pressure	3...5 bar
Differential pressure*) at	
3 bar system pressure	min. 1.5 bar
5 bar system pressure	min. 3.5 bar
Air flow rate **)	10...20 l/min

*) Minimum pressure difference, if one or several position monitorings are not operated.

***) For measuring of the flow rate appropriate devices are available.

Function chart

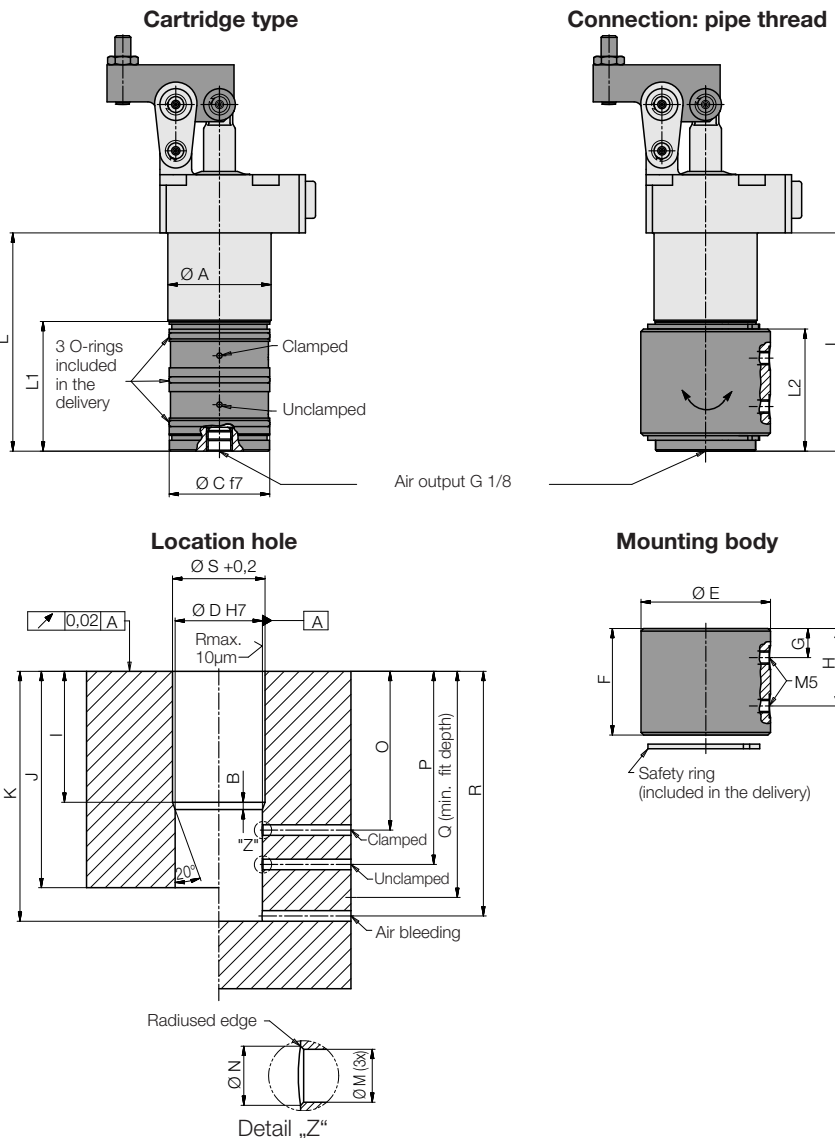
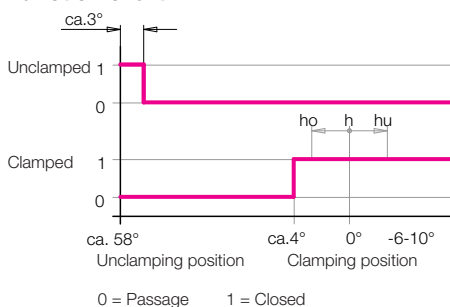

Size		1	2	3	4	5
Ø A ±0.1	[mm]	39	47	53	63	78
B	[mm]	1.3	2	2	2	2
Ø C f7	[mm]	38	42	42	45	45
Ø D H7	[mm]	38	42	42	45	45
Ø E	[mm]	49	53	52.5	62.5	62.5
F	[mm]	40.3	46	50	54	60
G	[mm]	11	13	14	14	15
H	[mm]	29.3	33	36	40	45
I +0.2	[mm]	34	40	43	47.5	55.5
J min.	[mm]	78	87	91	100	114
K min.	[mm]	84	95	100	109	123
L	[mm]	82.5	93.5	98.5	107	121.5
L1	[mm]	49	54	56	60	66.5
L2	[mm]	46.15	53.85	55.8	59.8	65.8
Ø M	[mm]	4	4	4	4	4
Ø N	[mm]	5	5	5	5	5
O	[mm]	46	52	55.5	60	70.6
P	[mm]	65	74	80	86	100.5
Q min.	[mm]	77	85	90	98.5	113
R	[mm]	79.5	90.5	95.5	104	118.5
Ø S max.	[mm]	40	48	54	64	79

Part no.

Cartridge type with 4 screws	0353-341	0353-342	0353-343	0353-344	0353-345
Mounting body	0353-341A	0353-342A	0353-343A	0353-344A	0353-345A
for retrofitting of the cartridge type					

Accessories

Electrical position monitoring • Important notes

Application

The electrical position monitoring signals the following conditions due to damping of two inductive proximity switches:

1. Piston retracted and clamping lever in off-position
2. Piston extended and clamping lever in off-position.

For each control function, an electrical line has to be provided at the clamping fixture.

Description

The electrical position monitoring can be easily retrofitted at all hinge clamps with switch rod (1826-7X4X).

Included in our delivery are:

- 1 Signal sleeve with screw
- 1 Adapter with 4 countersunk screw
- 1 Control housing with 3 set screws
- 2 Inductive proximity switches with right angle plug (if ordered)

The signal sleeve is screwed onto the switch rod. The adapter is mounted with 4 countersunk screws at the bottom cover.

The control housing can be put onto the adapter in any angular position and locked with 3 set screws. For information on adjustment of proximity switches, see operating manual.

Important notes

Inductive position monitorings are not suitable for the use in coolant and swarf areas. According to the corresponding application conditions, safety measures have to be planned and checked later on.

Technical data

Voltage	10...30 V DC
Residual ripple max.	10 %
Max. constant current	100 mA
Switching function	interlock
Output	PNP
Housing material	stainless steel
Thread	M 5 x 0.5
Code class	IP 67
Environment temperature	-25...+70 °C
LED Function display	yes
Short-circuit proof	yes
Connection	plug
Cable length	5 m

Function chart

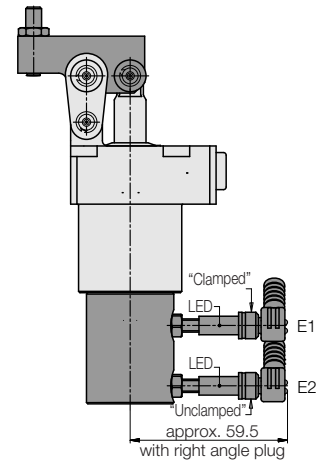
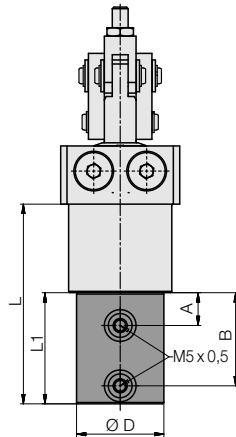
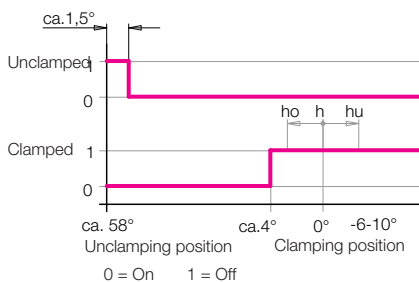

Four fixing screws included in our delivery.

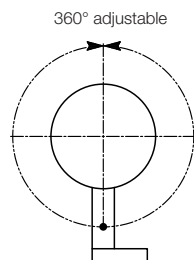

Possible position of the proximity switches

Size	1	2	3	4	5
A	[mm] 12.5	12.5	10.5	10	12
B	[mm] 35	37	38.5	42.5	50
Ø D	[mm] 33	42	42	45	45
L	[mm] 75.5	84.5	91.5	103.5	117
L1	[mm] 42	45	49	56.5	62
Part no.					
Without switch	0353-351	0353-352	0353-353	0353-354	0353-355
With switch and plug	0353-351S	0353-352S	0353-353S	0353-354S	0353-355S
Spare parts					
Inductive proximity switch	3829-198	3829-198	3829-198	3829-198	3829-198
Right angle plug with cable 5m	3829-099	3829-099	3829-099	3829-099	3829-099